

# **IMPULSE<sup>®</sup>•G+** *Mini*

---

Adjustable Frequency Crane Controls

## **Advanced Instruction Manual**



**MAGNETEK**  
MATERIAL HANDLING

Software # 14511 September 2011  
Part Number: 144-25085-R4  
© Copyright 2011 Magnetek



©2011 Magnetek

All rights reserved. This notice applies to all copyrighted materials included with this product, including, but not limited to, this manual and software embodied within the product. This manual is intended for the sole use of the persons to whom it was provided, and any unauthorized distribution of the manual or dispersal of its contents is strictly forbidden. This manual may not be reproduced in whole or in part by any means whatsoever without the expressed written permission of Magnetek.

### PRODUCT SAFETY INFORMATION

Magnetek, Inc. (Magnetek) offers a broad range of radio remote control products, control products and adjustable frequency drives, and industrial braking systems for material handling applications. This manual has been prepared by Magnetek to provide information and recommendations for the installation, use, operation and service of Magnetek's material handling products and systems (Magnetek Products). Anyone who uses, operates, maintains, services, installs or owns Magnetek Products should know, understand and follow the instructions and safety recommendations in this manual for Magnetek Products.

The recommendations in this manual do not take precedence over any of the following requirements relating to cranes, hoists lifting devices or other material handling equipment which use or include Magnetek Products:

- Instructions, manuals, and safety warnings of the manufacturers of the equipment where the Magnetek Products are used,
- Plant safety rules and procedures of the employers and the owners of the facilities where the Magnetek Products are being used,
- Regulations issued by the Occupational Health and Safety Administration (OSHA),
- Applicable local, state or federal codes, ordinances, standards and requirements, or
- Safety standards and practices for the industries in which Magnetek Products are used.

This manual does not include or address the specific instructions and safety warnings of these manufacturers or any of the other requirements listed above. It is the responsibility of the owners, users and operators of the Magnetek Products to know, understand and follow all of these requirements. It is the responsibility of the employer to make its employees aware of all of the above listed requirements and to make certain that all operators are properly trained. **No one should use Magnetek Products prior to becoming familiar with and being trained in these requirements and the instructions and safety recommendations for this manual.**

### PRODUCT WARRANTY INFORMATION

Magnetek, hereafter referred to as Company, assumes no responsibility for improper programming of a drive by untrained personnel. A drive should only be programmed by a trained technician who has read and understands the contents of this manual. Improper programming of a drive can lead to unexpected, undesirable, or unsafe operation or performance of the drive. This may result in damage to equipment or personal injury. Company shall not be liable for economic loss, property damage, or other consequential damages or physical injury sustained by the purchaser or by any third party as a result of such programming. Company neither assumes nor authorizes any other person to assume for Company any other liability in connection with the sale or use of this product.

For information on Magnetek's product warranties by product type, please visit [www.magnetekmh.com](http://www.magnetekmh.com).



### WARNING

Improper programming of a drive can lead to unexpected, undesirable, or unsafe operation or performance of the drive.

# ***DANGER, WARNING, CAUTION, and NOTE* Statements**

*DANGER, WARNING, CAUTION, and NOTE* statements are used throughout this manual to emphasize important and critical information. You must read these statements to help ensure safety and to prevent product damage. The statements are defined below.



## **DANGER**

*DANGER* indicates an imminently hazardous situation which, if not avoided, will result in death or serious injury. This signal word is to be limited to the most extreme situations.



## **WARNING**

*WARNING* indicates a potentially hazardous situation which, if not avoided, could result in death or serious injury.



## **CAUTION**

*CAUTION* indicates a potentially hazardous situation which, if not avoided, could result in minor or moderate injury. It may also be used to alert against unsafe practices.

*NOTE:* A *NOTE* statement is used to notify installation, operation, programming, or maintenance information that is important, but not hazard-related.

## Contents:

Product Warranty Information .....	ii-iii
------------------------------------	--------

## Chapter 1: Introduction

Introduction .....	1-4
General Specifications .....	1-5

## Chapter 2: Installation

Assessing the System Requirements .....	2-3
Long Time Storage .....	2-5
Dimensions/Heat Loss - Open Chassis .....	2-7
Installing the Drive .....	2-8

## Chapter 3: Wiring

Wiring Practices .....	3-3
Typical Connection Diagram .....	3-5
Safe Disable Function .....	3-7
Suggested Circuit Protection Specifications and Wire Size .....	3-8

## Chapter 4: Getting Started

Overview .....	4-3
Using the Keypad .....	4-4
Keypad LED and Button Functions .....	4-5
Quick Start Guide Information .....	4-7
Parameter Modes .....	4-11
Initialization Set-Up .....	4-13
Auto-Tuning .....	4-20
Using Auto-Tuning .....	4-21

## Chapter 5 : Programming Features

Application .....	5-3
Preset Reference .....	5-3
Reference Limits .....	5-5
Sequence/Reference Source .....	5-6
Acceleration/Deceleration .....	5-14
Jump Frequencies .....	5-15
Special Functions .....	5-16
Quick Stop .....	5-17
Reverse Plug Simulation .....	5-18
Micro-Positioning Control .....	5-19
Travel Limits .....	5-20
Phantom Stop .....	5-21
Klixon Action .....	5-21
Load Check II .....	5-22
Swift Lift .....	5-25
Torque Limit (Open Loop Vector Only) .....	5-29
Brake Delay Timers .....	5-31
ON/OFF Delay Timer Functions .....	5-31
Maintenance Timer .....	5-32
Inching Control .....	5-33
Tuning .....	5-34
DC Injection .....	5-34
Automatic Slip Compensation .....	5-36
Torque Compensation .....	5-36
Dwell Function .....	5-38
S-Curve Acceleration/Deceleration .....	5-39
Carrier Frequency .....	5-40
Hunting Prevention .....	5-41
Motor Parameters .....	5-42
Voltage/Frequency Pattern .....	5-42
Motor Set-Up .....	5-45

Option Parameters .....	5-46
Pulse Generated (PG) Control .....	5-46
Terminal Parameters .....	5-47
Digital Inputs .....	5-47
External Fault Response Selection .....	5-51
Digital Outputs .....	5-52
Analog Inputs .....	5-56
Analog Outputs .....	5-58
Serial Communication Set-Up .....	5-59
Pulse Inputs .....	5-61
Protection Parameters .....	5-62
Motor Overload .....	5-62
Power Loss Ride Thru .....	5-64
Stall Prevention .....	5-65
Reference Detection .....	5-71
Torque Detection .....	5-73
Hardware Protection .....	5-76
Automatic Reset .....	5-78
Motor Tuning .....	5-81
Automatic Frequency Regulator Tuning (OLV Only) .....	5-81
Online Tuning .....	5-83
Operator Parameters .....	5-84
Motor Selection .....	5-84
Keypad Key Selection .....	5-86
Clear History .....	5-87
Monitor Parameters .....	5-89
Fault Trace .....	5-91
Fault History .....	5-91
Maintenance .....	5-92
Motor Control Monitor .....	5-92

## **Chapter 6: Troubleshooting**

Troubleshooting the Drive .....	6-3
Maintenance and Inspection .....	6-3
Minor Faults and Corrective Actions .....	6-3
Drive Faults, Alarms and Indicators .....	6-4
Fault Display and Corrective Actions at Auto-tuning .....	6-10
Power Section Check .....	6-11

## **Appendix A: Parameter Listing**

Parameter Listings .....	A-3
--------------------------	-----



# *Chapter 1*

## **Introduction**

This page intentionally left blank.



## WARNING

Read and understand this manual before installing, operating, or servicing this drive. All warnings, cautions, and instructions must be followed. All activity must be performed by qualified personnel. The drive must be installed according to this manual and local codes.

Do not touch any circuitry components while the main AC power is on. In addition, you must wait until the red “CHARGE” LED is out before performing any service on that unit. (As you look at the face of the circuitry, the “CHARGE” LED is located inside the left side of the Drive.) It may take as long as ten minutes for the charge on the main DC bus capacitors to drop to a safe level.

Do not check signals during operation.

Do not connect the main output terminals (U/T1, V/T2, W/T3) to the incoming, three-phase AC source.

Before executing Auto-Tuning, ensure that the motor is disconnected from the drive train, and the electric brake is set (locked) closed to ensure the load does not move. If the electric brake cannot be released, you must ensure that the brake is disengaged for the entire tuning process.

Do not connect or disconnect wiring while the power is on. Do not remove covers or touch circuit boards while the power is on. Do not remove or insert the digital operator while power is on.

Before servicing, disconnect all power to the equipment. The internal capacitor remains charged even after the power supply is turned off. The charge indicator LED will extinguish when the DC bus voltage is below 50VDC. To prevent electric shock, wait at least ten minutes after all indicators are OFF and measure DC bus voltage level to confirm safe level.

Do not perform a withstand voltage test on any part of the unit. This equipment uses sensitive devices and may be damaged by high voltage.

The Drive is suitable for circuits capable of delivering not more than 30,000 RMS symmetrical Amperes, 240VAC maximum (230V Class) and 480VAC maximum (460V Class). Install adequate branch circuit short circuit protection per applicable codes. Failure to do so may result in equipment damage and/or personal injury.

Do not connect unapproved LC or RC interference suppression filters, capacitors, or overvoltage protection devices to the output of the Drive. These devices may generate peak currents that exceed Drive specifications.

# Introduction

The IMPULSE•G+ Mini drive is the next generation of Magnetek, Inc. drives, providing compact and economical crane control. The drive maintains a similar footprint size and feature set of previous generation drives, while offering expanded capabilities in both Basic and Advanced modes. The drive is configured by default as BASIC with features that include:

- Volts/Hertz Control
- X-Press Programming™
- Swift-Lift™
- Reverse Plug Simulation™
- Quick Stop™
- End-of-Travel Limits
- RS485 Communications

Switching the IMPULSE•G+ Mini to ADVANCED mode enables many additional control features, including:

- Open-Loop Vector Control
- Micro-Positioning Control™
- Up to 15 Discrete Speed References
- Load Check II™
- Maintenance Timers
- No-Load Brake\*
- Braketronic™
- Expanded Programmable Input/Output Capabilities

*NOTE: \*For approved OEM vendors or suppliers*

This manual will provide support for the basic and advanced operating features of IMPULSE•G+ Mini. For additional information, visit [www.magnetekmh.com/manuals.htm](http://www.magnetekmh.com/manuals.htm).

# IMPULSE•G+ Mini General Specifications

## 230V Class

Specification	Specification Values and Information for Each 230V-Class Model									
	2001	2003	2005	2008	2011	2017	2025	2033	2047	2060
Rated current (A)	1.6	3.0	5.0	8.0	11.0	17.5	25.0	33.0	47.0	60.0
Capacity (kVA)	0.6	1.1	1.9	3.0	4.2	6.7	9.5	12.6	17.9	22.9

## 460V Class

Specification	Specification Values and Information for Each 460V-Class Model									
	4001	4002	4003	4004	4009	4014	4018	4024	4031	
Rated current (A)	1.2	1.8	3.4	4.8	9.2	14.8	18.0	24.0	31.0	
Capacity (kVA)	0.9	1.4	2.6	3.7	7.0	11.3	13.7	18.3	23.6	

## 230V and 460V Classes

Specification	Specification Value and Information for All Models
Certification	UL, cUL, CSA, CE, TÜV, RoHS
Rated input power supply volts & freq	3-phase 200–240V or 380–480V; 50/60 Hz
Allowable input voltage fluctuation	+10% or -15% of nominal
Allowable input frequency fluctuation	±5% of nominal
Control method	Fully digital; sine-wave, pulse-width-modulated
Maximum output voltage (VAC)	Max output voltage 3-phase, 200–240V; 380–480V (proportional to input voltage).
Rated frequency (Hz)	Up to twice motor nameplate RPM (Swift-Lift) 60 Hz standard (150 Hz, consult factory)
Output speed control range	40:1 - V/f, 100:1 - Open Loop Vector (OLV)
Output frequency accuracy	0.01%—with digital reference command 0.1%—with analog reference command; 10 bits/10V
Frequency reference resolution	Digital: 0.01 Hz; analog: 0.03 Hz (at 60 Hz)
Output frequency resolution	0.01 Hz
Overload capacity	150% of rated output current of the drive for 1 minute
Remote frequency reference sources	0–10VDC (2kΩ); 4–20mA (250Ω); serial (RS-485)
Accel/decel times	0.0 to 25.5 seconds - 1 set; 0.0 to 6000.0 - 3 sets; 8 parameters are independently adjustable
Braking torque	150% or more with dynamic braking
Motor overload protection	UL recognized electronic thermal overload relay; field-programmable
Overcurrent protection level	200% of drive rated current
Circuit protection	Ground fault and blown-fuse protection
Overvoltage protection level	Approximately 410VDC (230V Class), 820VDC (460V Class)
Undervoltage protection level	Approximately 190VDC (230V Class), 380VDC (460V Class)
Heatsink overtemperature	Thermostat trips at 184–249°F (90 - 121°C), dependent on drive capacity
Torque limit selection	Separate functions for FORWARD, REVERSE, REGEN.; all selectable from 0–300%
Stall prevention	Separate functions for accel, decel, at-speed, and constant horsepower region

<b>Specification</b>	<b>Specification Value and Information for All Models</b>
Other protection features	Lost output phase, failed-oscillator, mechanical overload, and internal braking transistor failure.
DC bus voltage indication	Charge LED is on until DC bus voltage drops below 50VDC
Location	Indoors; requires protection from moisture, corrosive gases, and liquids
Ambient operating temperature	14° to 122°F (-10° to 50°C) (Consult factory for applications exceeding temperature range)
Storage temperature	-4° to 140°F (-20° to 60°C)
Humidity	95% relative; noncondensing
Vibration	1 G less than 20 Hz; 0.2 G for 20–55 Hz
Elevation	3300 Ft. (1000m) or less
Memobus	RS485/422 Max 115.2 Kbps

## AC Reactor Specifications

Reactors, both as input (line) and output (load) devices, protect adjustable frequency drives, motors, and other load devices against excessive voltage and current.

The following guidelines may help determine input and output reactor requirements:

- Install an input reactor if the power source is greater than 500kVA.
- Ensure the drive-to-motor wiring distance is less than 150 ft. unless appropriate reactors, filters, and/or Inverter Duty motor is used.
- Install an output reactor if a device, such as a power limit switch, is used to disconnect the motor from the drive.
- Install one output reactor per drive for a multiple-drive arrangement requiring reactor protection.
- For a multiple drive arrangement, an input reactor for each drive is recommended for optimal protection. However, if the drives are within two drive sizes of each other, a single input reactor can be used. The reactor must be rated at amperage equal to or greater than the sum of the amperage for all the drives.

### 230V Class

<b>Model Number</b>	<b>230V Part Number</b>	<b>Maximum Amps of Reactor</b>
2001-G+M	REA230-1	4
2003-G+M	REA230-1	4
2005-G+M	REA230-1	4
2008-G+M	REA230-2	8
2011-G+M	REA230-3	12
2017-G+M	REA230-5	18
2025-G+M	REA230-7.5	25
2033-G+M	REA230-10	35
2047-G+M	REA230-15	45
2060-G+M	REA230-20	55

## 460V Class

Model Number	460 V Part Number	Maximum Amps of Reactor
4001-G+M	REA460-1	2
4002-G+M	REA460-1	2
4003-G+M	REA460-2	4
4004-G+M	REA460-3	4
4009-G+M	REA460-5	8
4014-G+M	REA460-7.5	12
4018-G+M	REA460-10	18
4024-G+M	REA460-15	25
4031-G+M	REA460-20	35

## IMPULSE•G+ Mini External Resistor Specifications

If Magnetek resistors are not used, this table should be used to determine the minimum resistance values.

	IMPULSE•G+ Mini	Traverse				Hoist w/ Mechanical Load Brake	
		Resistor Part No.	Resistance	Resistor Part No.	Resistance	Resistor Part No.	Resistance
		Model Number	CMAA Class A, B, C	Ω	CMAA Class D	Ω	CMAA Class A, B, C, D
230 Volts	2001-G+M	EDB2001CT	220	EDB2001DTP	220	EDB2001CT	220
	2003-G+M	EDB2001CT	220	EDB2001DTP	220	EDB2001CT	220
	2005-G+M	EDB2003CT	110	EDB2004DTP*	100	EDB2003CT	110
	2008-G+M	EDB2006CT	58	EDB2006DTP*	44	EDB2003CT	110
	2011-G+M	EDB2009CT	37	EDB2011DTP*	31	EDB2006CT	58
	2017-G+M	EDB2015CT	25	EDB2015DTP*	25	EDB2009CT	37
	2025-G+M	EDB2022CT*	14	EDB2022DT*	14	EDB2015CT	25
	2033-G+M	EDB2028CT*	13	EDB2028DT*	12	EDB2015CT	25
	2047-G+M	EDB2042CT*	7.8	EDB2042DT*	6.5	EDB2022CT*	14
	2060-G+M	EDB2054CT*	6	--	4.8	EDB2028CT*	13
460 Volts	4001-G+M	EDB4001CT	440	EDB4001DTP	440	EDB4001CT	440
	4002-G+M	EDB4001CT	440	EDB4002DTP*	354	EDB4001CT	440
	4003-G+M	EDB4003CT	230	EDB4004DTP*	187	EDB4001CT	440
	4004-G+M	EDB4004CT	150	EDB4005DTP*	133	EDB4003CT	230
	4009-G+M	EDB4007CT	100	EDB4008DTP*	84	EDB4004CT	150
	4014-G+M	EDB4011CT*	59	EDB4011DT*	47	EDB4007CT	100
	4018-G+M	EDB4014CT*	46	EDB4014DT*	37	EDB4007CT	100
	4024-G+M	EDB4021CT*	31.1	EDB4021DT*	24.9	EDB4011CT*	59
	4031-G+M	EDB4027CT*	24.2	EDB4027DT*	22	EDB4014CT*	46

\* Resistors are supplied in vented indoor enclosure.

This page intentionally left blank.



# *Chapter* 2

## **Installation**

This page intentionally left blank.

# Assessing The System Requirements



## WARNING

- When preparing to mount the IMPULSE•G+ Mini drive, lift it by its base. Never lift it by the front cover.
- Mount the drive on nonflammable material.
- The IMPULSE•G+ Mini drive generates heat. For the most effective cooling possible, mount it vertically. For more details, refer to the “IMPULSE•G+ Mini Dimensions/Heat Loss—Open Chassis” in this chapter.
- When mounting units in an enclosure, install a fan or other cooling device to keep the enclosure temperature below 122°F (50°C).

*Failure to observe these warnings may result in equipment damage.*

It is important to know how you are going to use the drive before you start installation and wiring. You will need to know your requirements for the following components:

- Motion (traverse or hoist)
- Motor HP, RPM, and FLA
- Speed control method (2-speed, 3-speed, multistep, etc.)
- Stopping method (Decelerate or Coast to Stop)
- Wire size
- Grounding location and method

### Choosing a Location

Be sure the drive is mounted in a location protected against the following conditions:

- Extreme cold and heat. Use only within the ambient temperature range:  
Open Chassis: +14 to 122°F (-10 to 50°C)
- Direct sunlight (not for use outdoors)
- Rain, moisture
- High humidity
- Oil sprays, splashes
- Salt spray
- Dust or metallic particles in the air
- Corrosive gases (e.g. sulfurized gas or liquids)
- Radioactive substances
- Combustibles (e.g. thinner, solvents, etc.)
- Physical shock, vibration
- Magnetic noise (e.g. welding machines, power devices, etc.)

## **IMPULSE•G+ Mini System Components And External Devices**

### **Optional Drive Components**

- 120 VAC Interface Card (Part Number G+M-IF-120VAC)
- 48 VAC Interface Card (Part Number G+M-IF-48VAC)
- 24 VAC Interface Card (Part Number G+M-IF-24VAC)
- P3S2OUT2 Card (Part Number P3S2-OUT2-KIT)
- Copy Stick (Part Number COPY-STICK)
- Basic Instruction Manual (Part Number G+ MINI BASIC MODE INST. MANUAL)

### **As-Required Drive Components**

- AC reactor—line or load
- DC bus reactor
- External dynamic braking resistor(s)
- External dynamic braking unit

### **Required External Devices**

- Motor
- User input device (pendant, joystick, PC, PLC, radio, or infrared control)
- External circuit protection devices (fuses or circuit breakers) (See “Suggested Circuit Protection Specifications and Wire Size” in Chapter 3.)
- R-C surge suppressors on contactor coils

## Long Time Storage

Powering up the drives every six months is quite beneficial. Over longer periods of time without power, the drives' electrolytic DC bus capacitors require reformation, especially if stored in an area of high temperatures. Capacitor reforming is required if drives are stored without power for more than 2 to 3 years. This process can be avoided by powering up the drive bi-annually for 30 to 60 minutes.

*NOTE: Bus cap reforming alone may not restore full drive functionality after 2 to 3 years of storage without power.*

Inverter drives contain large bus capacitors that have the potential to be reformed. However, printed circuit boards also contain electrolytic capacitors that may not function after several years without power. Magnetek recommends replacing the PCBs should the drive's functionality not be restored after bus cap reforming. Contact Magnetek Service for questions.

### Capacitor Storage and their Reforming Process

The electrical characteristics of aluminum electrolytic capacitors are dependent on temperature; the higher the ambient temperature, the faster the deterioration of the electrical characteristics (i.e., leakage current increase, capacitance drop, etc.). If an aluminum electrolytic capacitor is exposed to high temperatures such as direct sunlight, heating elements, etc., the life of the capacitor may be adversely affected. When capacitors are stored under humid conditions for long periods of time, the humidity will cause the lead wires and terminals to oxidize, which impairs their solderability. Therefore, aluminum electrolytic capacitors should be stored at room temperature, in a dry location and out of direct sunlight.

In the event that a capacitor has been stored in a high ambient environment for more than 2 or 3 years, a voltage treatment reformation process to electrolytic capacitors may have to be performed. When stored above room temperatures for long periods of time, the anode foil may react with the electrolyte, increasing the leakage current. After storage, the application of even normal voltages to these capacitors may result in higher than normal leakage currents. In most cases the leakage current levels will decrease in a short period of time as the normal chemical reaction within the capacitor occurs. However, in extreme cases, the amount of gas generated may cause the safety vent to open.

Capacitors, when used in inverter drives that are stored for long periods of time, should be subjected to a voltage treatment/reforming process as noted below, which will reform the dielectric and return the leakage current to the initial level.

- Inverter Bus Capacitor Reforming Procedure:
- Connect the inverter inputs L1 and L2 to a variac.
- Make sure the variac voltage setting is turned down so that when input power is applied to the variac, the output of the variac will be at or near 0 volts.
- Apply power to the variac, listening for abnormal sounds and watching for abnormal visual indications in the drive. If the variac has an output current indication, make sure the current is very near zero with zero or a steady output voltage applied.
- Slowly turn the variac up, increasing the variac's output voltage to nominal rated input voltage over a time period of 2 to 3 minutes. In other words, ramp the voltage up at a rate of approximately 75 to 100 volts/minute for 230 VAC units, 150 to 200 volts/minute for 460 VAC units, and 225 to 300 volts/minute for 575 VAC.
- Let the output voltage remain at rated voltage for 30 to 60 minutes while keeping close watch for

abnormal signs within the inverter. While increasing the variac's output voltage, the current will momentarily increase as current is necessary to charge the capacitors.

- Once 30 to 60 minutes elapse, remove power and package the drive for shipment.

If any abnormal indications occur during this process, it is recommended that the process be repeated. Otherwise, this completes the capacitor reforming procedure.

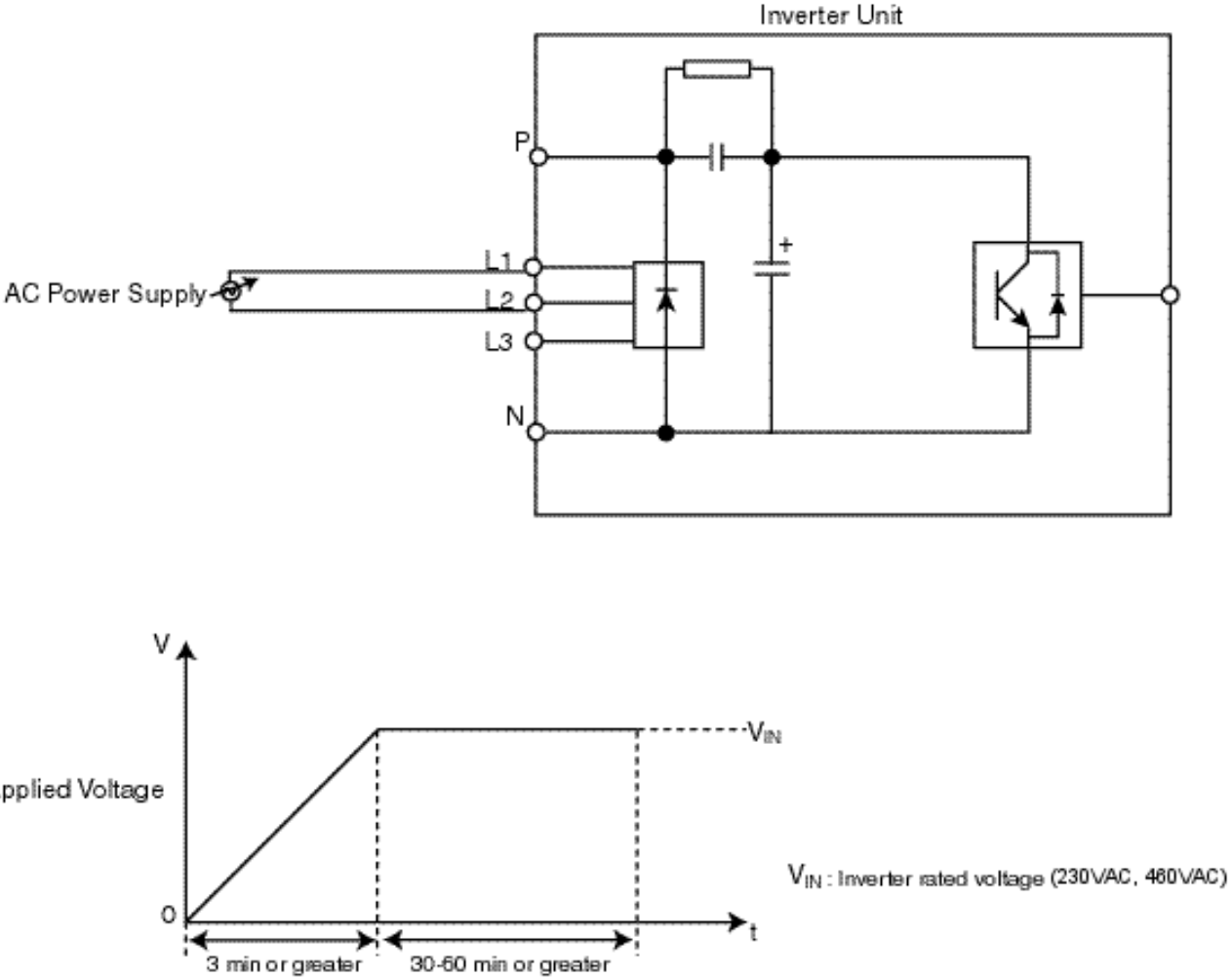

Figure 2-1: Long Time Storage

# IMPULSE•G+ Mini Dimensions/Heat Loss - Open Chassis\*

Voltage	Model	W	H	D	W1	H1	d	Wt. Lbs.	Total Heat Loss (W)**
<b>Dimensions in Inches</b>									
230V	2001-G+M	2.68	5.04	2.99	2.20	4.65	M4	1.3	14.7
	2003-G+M	2.68	5.04	4.25	2.20	4.65	M4	2.0	24.0
	2005-G+M	2.68	5.04	5.04	2.20	4.65	M4	2.4	36.7
	2008-G+M	4.25	5.04	5.08	3.78	4.65	M4	3.7	61.9
	2011-G+M	4.25	5.04	5.41	3.78	4.65	M4	3.7	81.3
	2017-G+M	5.51	5.04	5.63	5.04	4.65	M4	5.3	122.7
	2025-G+M	5.51	10.00	5.51	4.80	9.76	M5	8.4	248.5
	2033-G+M	5.51	10.00	5.51	4.80	9.76	M5	8.4	282.6
	2047-G+M	7.09	11.42	6.42	6.30	11.18	M5	12.1	389.7
	2060-G+M	8.66	13.78	7.36	7.56	13.23	M5	20.3	563.8
460V	4001-G+M	4.25	5.04	3.19	3.78	4.65	M4	2.2	19.1
	4002-G+M	4.25	5.04	3.90	3.78	4.65	M4	2.6	27.1
	4003-G+M	4.25	5.04	5.41	3.78	4.65	M4	3.7	38.3
	4004-G+M	4.25	5.04	6.06	3.78	4.65	M4	3.7	57.4
	4009-G+M	5.51	5.04	5.63	5.04	4.65	M4	5.3	97.1
	4014-G+M	5.51	10.00	5.51	4.80	9.76	M5	8.4	173.4
	4018-G+M	5.51	10.00	5.51	4.80	9.76	M5	8.4	219.4
	4024-G+M	7.09	11.42	5.63	6.30	11.18	M5	11.5	283.8
	4031-G+M	7.09	11.42	6.42	6.30	11.18	M5	12.1	344.3

\*NOTE: Applications such as high duty cycles in conjunction with high ambient temperatures or other unique environmental conditions can impact drive ratings. Please consult factory. Due to ongoing improvements, data is subject to change without notice.

\*\* Heat loss for carrier frequency of 2.0 kHz (heavy duty).

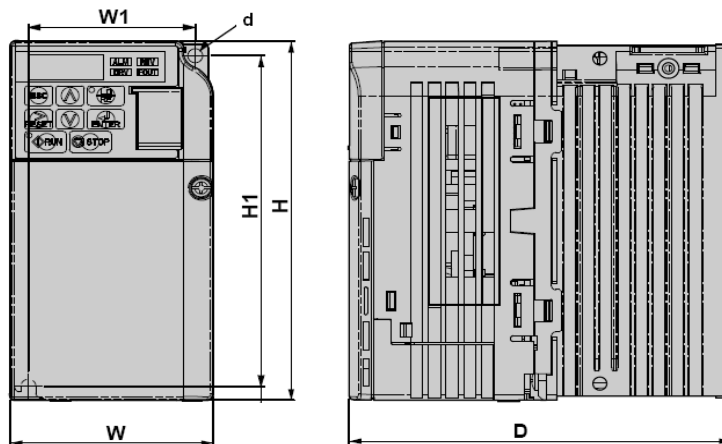

# Installing the Drive

The following two figures show the minimum clearances when mounting the drive in standard or side-by-side installations.

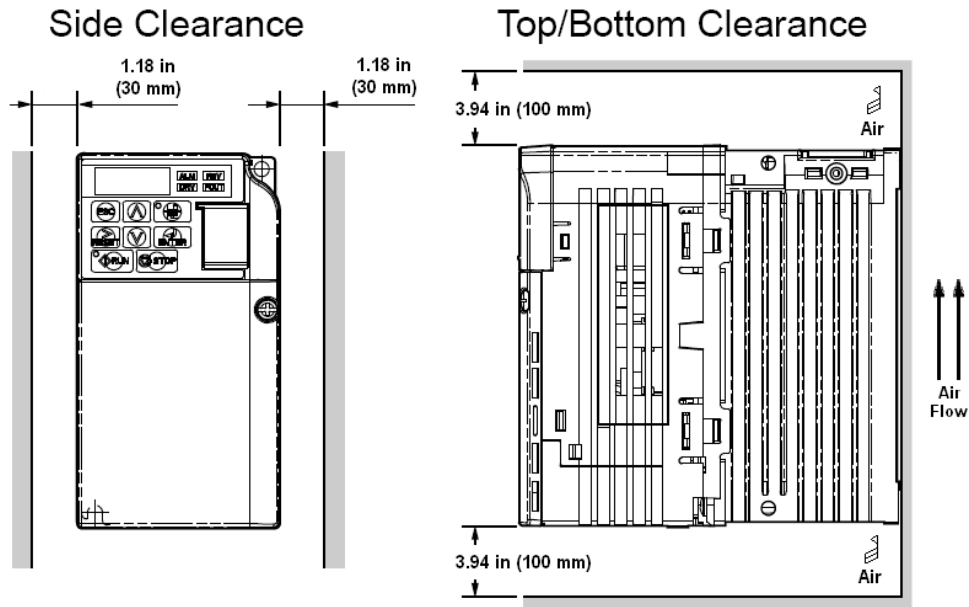
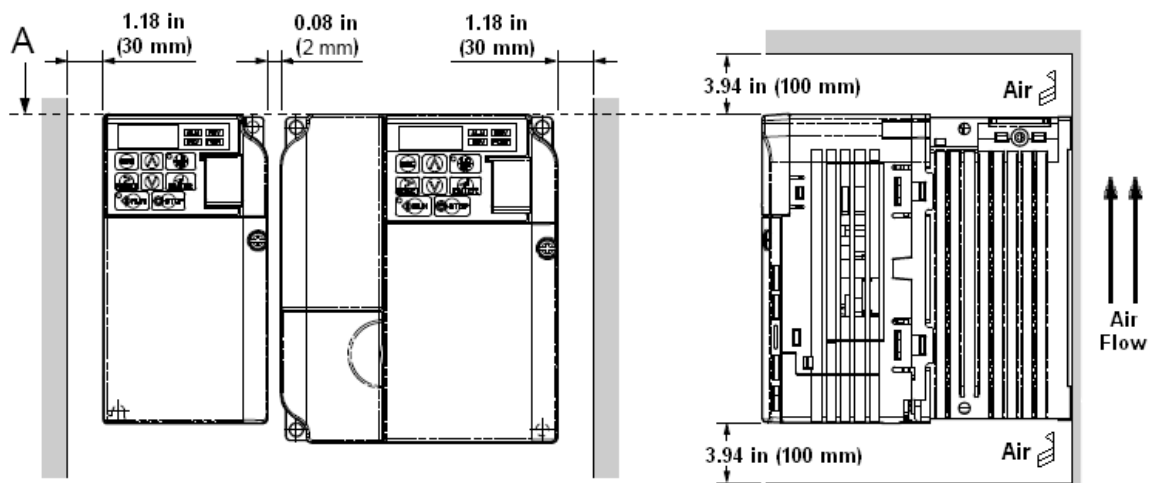

Figure 2-2: Standard Installation

# Installing the Drive (Side-by-Side)



A – Line up the tops of the drives.

Figure 2-3: Side-by-Side Installation



# *Chapter* 3

## **Wiring**

This page intentionally left blank.

# IMPULSE•G+ Mini Wiring Practices



## WARNING

Before you wire the drive, review the following practices to help ensure that your system is wired properly.

- Connect the incoming three-phase AC source to terminals R/L1, S/L2, T/L3.
- Connect the Motor leads to terminals U/T1, V/T2, W/T3.
- Ensure the drive-to-motor wiring distance is less than 150 ft unless appropriate reactors and/or filters are used.
- Install a line reactor between the output of the drive in applications that require a disconnecting means between the drive's output and motor. Use a "make before break" auxiliary contact with the disconnect means and the hardware base block of the drive.
- Use contacts between the PLC output and the drive 120/24/48 VAC input card. If using a solid state output from a PLC (TRIAC) to a 120/24/48 VAC input card, use a 5 K $\Omega$ , 5 Watt resistor between the signal and X2.
- If the power source is 500 kVA or greater, or more than 10 times the inverter kVA rating, ensure that there is at least 3 percent impedance between the power source and the drive input. To accomplish this, you can install a DC reactor between inverter terminals +1 and +2, or use an AC line reactor on the input of the drive. If you don't provide enough impedance, excessive peak currents could damage the input power supply circuit.
- Comply with "Suggested Circuit Protection Specifications and Wire Size" on page 3-8.
- Use time delay fuses, which are sized at 150% of drive's continuous-rated current, for drive input protection.
- Use appropriate R-C or MOV type surge absorbers across the coil of all contactors and relays in the system. Failure to do so could result in noise-related, nuisance fault incidents.
- Use external dynamic braking resistors for all applications.
- Do not ground the drive with any large-current machines.
- Before you use any welding or high-current machines near the crane, disconnect all line and ground wiring.
- Do not let the wiring leads come in contact with the drive enclosure.
- Do not connect power factor correction capacitors to the drive input or output.
- Hard-wire the drive and motor (e.g., festoon cable). Do not use sliding collector bars.
- If you have a user input device or interface board that is remote, use shielded cable between the drive input terminals and the interface output terminals or user input device(s).
- Before turning on the drive, check the output circuit (U/T1, V/T2 and W/T3) for possible short circuits and ground faults.
- Increase the wire size by one size for every 250 feet (76.2 meters) between the drive and motor; suggested for center driven cranes, trolleys, and bridges. (Voltage drop is significant at low frequencies.)

- When using more than one transformer for the drive's power, properly phase each transformer.
- To reverse the direction of rotation, interchange any two motor leads (U/T1, V/T2 or W/T3; changing R/L1, S/L2 or T/L3 will not affect the shaft rotation direction) or change parameter B03.04.
- Use shielded cable for all low-level DC speed reference signals (0 to 10VDC, 4 to 20 mA). Ground the shield only at the drive side.
- Please observe National Electrical Code (NEC) guidelines when wiring electrical devices.

*NOTE: Failure to observe these warnings may result in equipment damage.*

# IMPULSE•G+ Mini Typical Connection Diagram

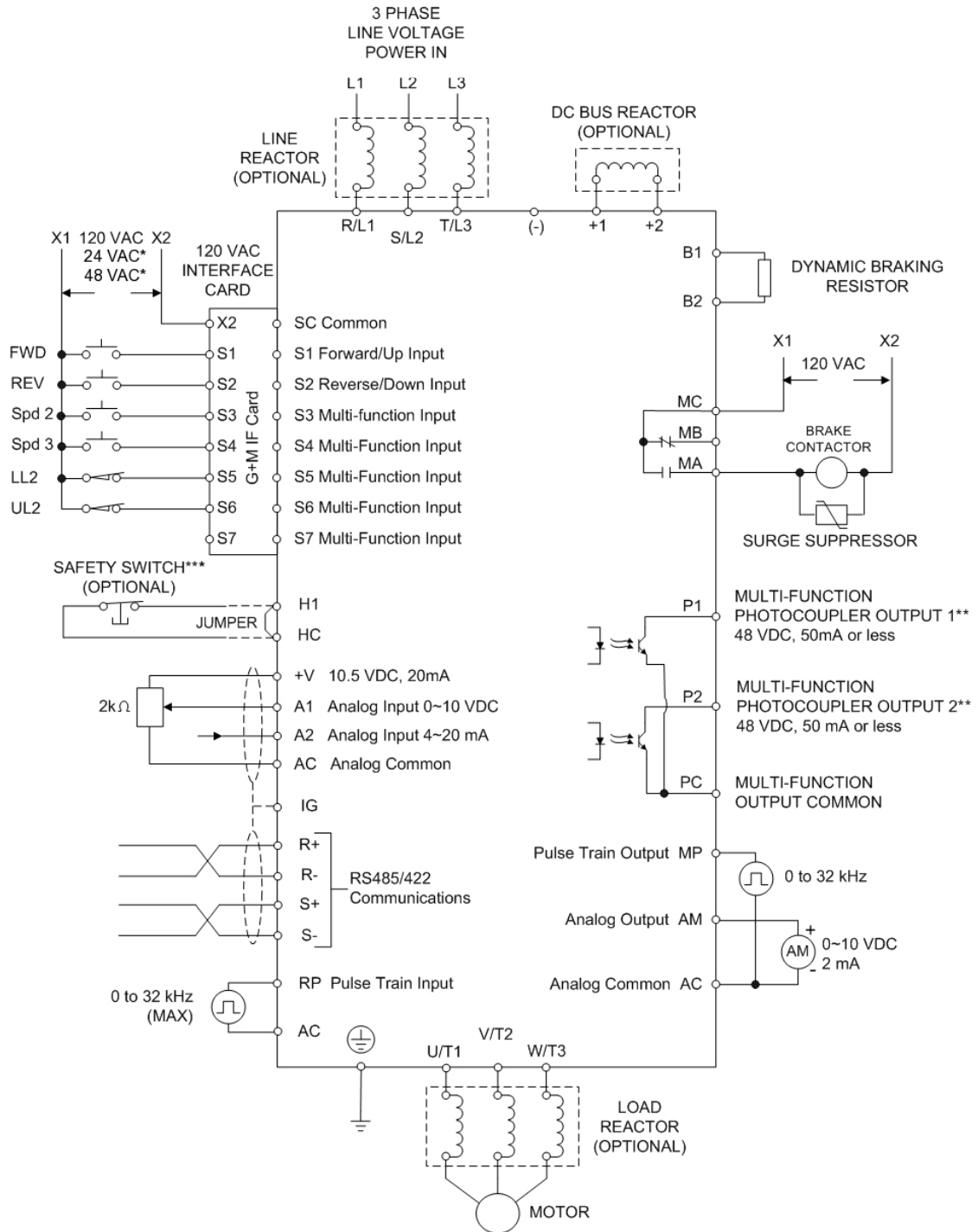

- \* Requires optional 24 VAC or 48 VAC Interface Boards
- \*\* Optional P3S2-OUT2 card provides two 240 VAC, 1.5 Amp solid-state relay outputs
- \*\*\* In accordance with UL508C, EN954-1 Safety Category 3, and EN61508, SIL2

Figure 3-1: IMPULSE•G+ Mini Typical Connection Diagram

# Terminal Description

Type	Terminal	Name	Function (Signal Level)			
Main Circuit	R/L1, S/L2, T/L3	AC power supply input	AC power supply input			
	U/T1, V/T2, W/T3	Inverter output	Inverter output			
	B1, B2	Braking resistor connection	Braking resistor connection			
	+2, +1	DC reactor connection	When connecting optional DC reactor, remove the main circuit short-circuit bar between +2 and +1.			
	+1, (-)	DC power supply input	DC power supply input (+1: positive; (-): negative)			
	⊕	Grounding	Ground to local grounding codes			
Control Circuit	Sequence	S1	Multi-function input selection 1	FWD run when closed, stop when open	H01.01 ~ H01.07	120VAC ±10%
		S2	Multi-function input selection 2	REV run when closed, stop when open		
		S3	Multi-function input selection 3	Inputs are programmable		
		S4	Multi-function input selection 4			
		S5	Multi-function input selection 5			
		S6	Multi-function input selection 6			
		S7	Multi-function input selection 7			
		X2*	Multi-function input selection common	Common for control signal		
	Analog Input Signal	+V	+10.5V DC Power supply output	For analog command +10V power supply		+10V (Allowable current 20 mA max)
		A1	Master frequency reference	0 to +10V/0 to 100%		0 to +10V/(2K Ohm)
		A2	Multi-function analog reference	4 to 20 mA/0 to 100%	H03.09	4 to 20 mA (250 Ohm), 0 to +10V/(2k Ohm)
		AC	Frequency reference common	0 to 10V/0 to 100%		
	Safe Disable Input	HC	Power Supply for safe disable input	+24 VDC (max 10 mA allowed)		
		H1	Safe disable input	Open: Output disabled Closed: Normal Operation <i>NOTE:</i> Disconnect wire jumper between HC and H1 when using the safe disable input. See Safe Disable Function on page 3-7.		
		RP	Pulse Input	Pulse Input frequency reference	H06.01	0 to 32kHz (3k Ω impedance) ±5% High level voltages 3.5 to 13.2 Low level voltages 0.0 to 0.8 Duty Cycle (on/off) 30% to 70%
	Multi-function contact output	MP	Pulse Monitor	Pulse output frequency	H06.06	0 to 32kHz ±5% output (load: 1.5k Ω)
		MA	NO contact output	Factory setting: brake output	H02.01	Dry contact capability: 250VAC 1A or less, 30VDC 1A or less
		MB	NC contact output			
		MC	Contact output common	Outputs are programmable	H02.02 ~ H02.03	Photo-coupler output +48VDC, 50mA or less
		P1	Photo coupler output 1			
		P2	Photo coupler output 2			
		PC	Photo coupler output common	0V	H04.01	+10VDC, 2mA or less, 8-bit resolution
		AM	Analog monitor output	Factory setting: output frequency 0 to +10V		
AC	Analog monitor common	0V				
MEMOBUS communications	R+	Communications input (+)	MEMOBUS communication Run through RS-485 or RS-422.	H05.01 ~ H05.08	RS-485/422 MEMOBUS protocol, 115.2 kbps max.	
	R-	Communications input (-)				
	S+	Communications output (+)				
	S-	Communications output (-)				
	I(G)	Signal Common	Connection to shield sheath of signal lead		0V	

\* SC when 24 VDC input option card is used.

# Safe Disable Function

The Safe Disable Function can be utilized to perform a safe stop according to the EN60204-1, stop category 0 (uncontrolled stop by power removal). It is designed to meet the requirements of the EN954-1, Safety Category 3 and EN61508, SIL2.

Removing the voltage from terminal H1 disables the drive output, i.e. the power supply to the motor is cut by stopping the switching of the output transistors in a safe way. “Hbb” is shown on the display. Safe Disable is applicable for induction and permanent magnet motors.

## Installation

If the Safe Disable function is utilized, the wire link between the terminals HC and H1 that is installed at shipment must be removed entirely.

Connect the drive to an EN954-1, Safety Category 3 interrupting device so that in case of a Safe Disable request, the connection between the terminals HC and H1 is opened.

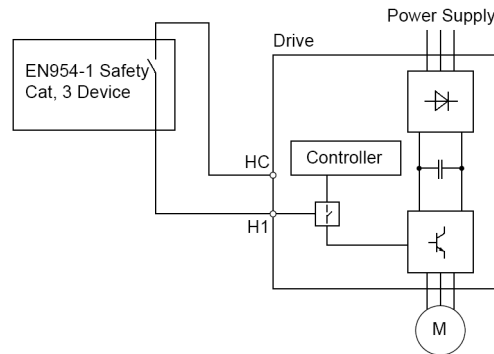

*Figure 3-2: Safe Disable Wiring Example*

### Installation Precautions:

- To ensure the Safe Disable function appropriately fulfills the safety requirements of the application a thorough risk assessment for the safety system must be carried out.
- The drive must be installed in an enclosure with a protection degree of at least IP54 in order to maintain EN954-1, safety category 3 compliance.
- If the safety device and the drive are installed in separate cabinets, install the Safe Disable wires in a manner preventing short circuits.
- The Safe Disable function does not cut the power supply to the drive and does not provide electrical isolation. Before any installation or maintenance work is done, the power supply of the drive must be switched off.
- The wiring distance for the Safe Disable inputs should not exceed 30 m (98 ft).
- The time from opening the Safe Disable input until the drive output is switched off is less than 1 ms.
- When utilizing the Safe Disable function use the recommended filters manufactured by Schaffner only.

# Suggested Circuit Protection Specifications and Wire Size

In order to comply with most safety standards, some circuit protective devices should be used between the incoming three-phase power supply and the IMPULSE•G+ Mini. These devices can be thermal, magnetic, or molded-case breakers (MCCB); or “slow-blow” type fuses such as “CCMR” or “J.”



## CAUTION:

The following guidelines are only suggested values. Always conform to local electrical codes and wiring practices.

Model #	Rated Current (A) Input Fuse	Time Delay Input Fuse Class	Inverse Time Molded/Case Circuit Breaker <sup>(3)</sup>	Wiring Size (AWG/KCML)			
				Power Circuit Wiring		Control Circuit Wiring	
				Applicable Gauge <sup>(1)</sup> (AWG)	Control Wiring (AWG)	Relay (AWG)	Ground Copper <sup>(2)</sup> AWG
<b>230V Class</b>							
2001-G+M	3	CC	15	18 to 14	18 to 16	18 to 16	14
2003-G+M	5	CC	15	18 to 14	18 to 16	18 to 16	14
2005-G+M	8	CC	15	18 to 14	18 to 16	18 to 16	14
2008-G+M	15	CC	15	14 to 10	18 to 16	18 to 16	12
2011-G+M	20	CC	20	14 to 10	18 to 16	18 to 16	12
2017-G+M	30	CC	35	14 to 10	18 to 16	18 to 16	10
2025-G+M	40	J	50	10 to 6	18 to 16	18 to 16	8
2033-G+M	50	J	70	10 to 6	18 to 16	18 to 16	8
2047-G+M	60	J	90	6 to 4	18 to 16	18 to 16	4
2060-G+M	80	J	110	8 to 2	18 to 16	18 to 16	4
<b>460V Class</b>							
4001-G+M	2	CC	15	14 to 10	18 to 16	18 to 16	14
4002-G+M	3	CC	15	14 to 10	18 to 16	18 to 16	14
4003-G+M	6	CC	15	14 to 10	18 to 16	18 to 16	14
4004-G+M	8	CC	15	14 to 10	18 to 16	18 to 16	14
4009-G+M	15	CC	15	14 to 10	18 to 16	18 to 16	12
4014-G+M	25	CC	30	14 to 10	18 to 16	18 to 16	10
4018-G+M	30	CC	40	10 to 6	18 to 16	18 to 16	10
4024-G+M	35	J	50	10 to 6	18 to 16	18 to 16	8
4031-G+M	45	J	60	10 to 6	18 to 16	18 to 16	8

References:

1. NFPA 70 National Electrical Code 2008 Table 610-14(a).
2. NFPA 70 National Electrical Code 2008. Table 250-122.
3. NFPA 70 National Electrical Code 2008. Table 430.52.



## Grounding

1. Connect terminal  $\text{⏚}$  to the common panel ground. Use ground wiring as specified in “Suggested Circuit Protection Specifications and Wire Size” on page 3-8, and keep the length as short as possible.
  - Ground Resistance: 230V class; 100 $\Omega$  or less, 460V or greater class; 10 $\Omega$  or less.
  - Never run the IMPULSE•G+ Mini drive ground wires in common with welding machines, or other high-current electrical equipment.
  - When more than one drive is used for the same system, ground each drive directly, or daisy-chain to the ground pole. Do not loop the ground wires.

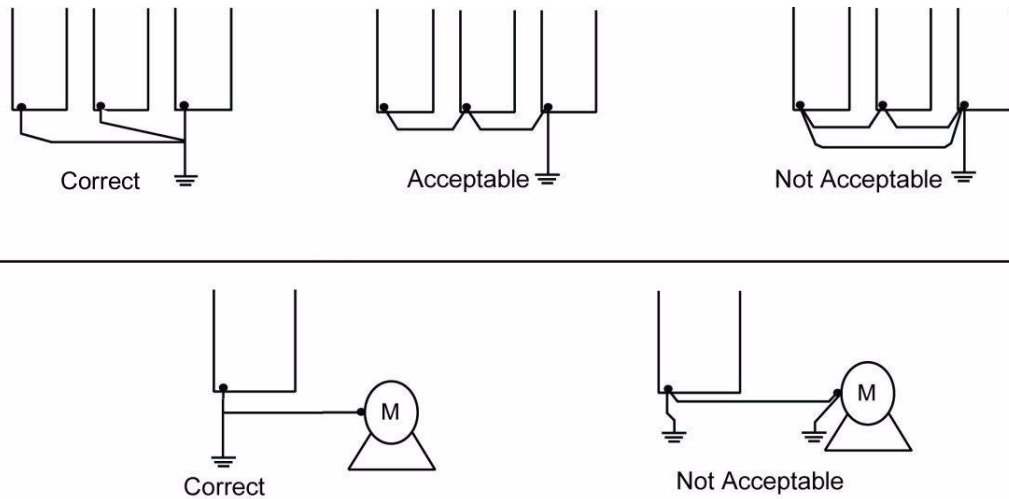
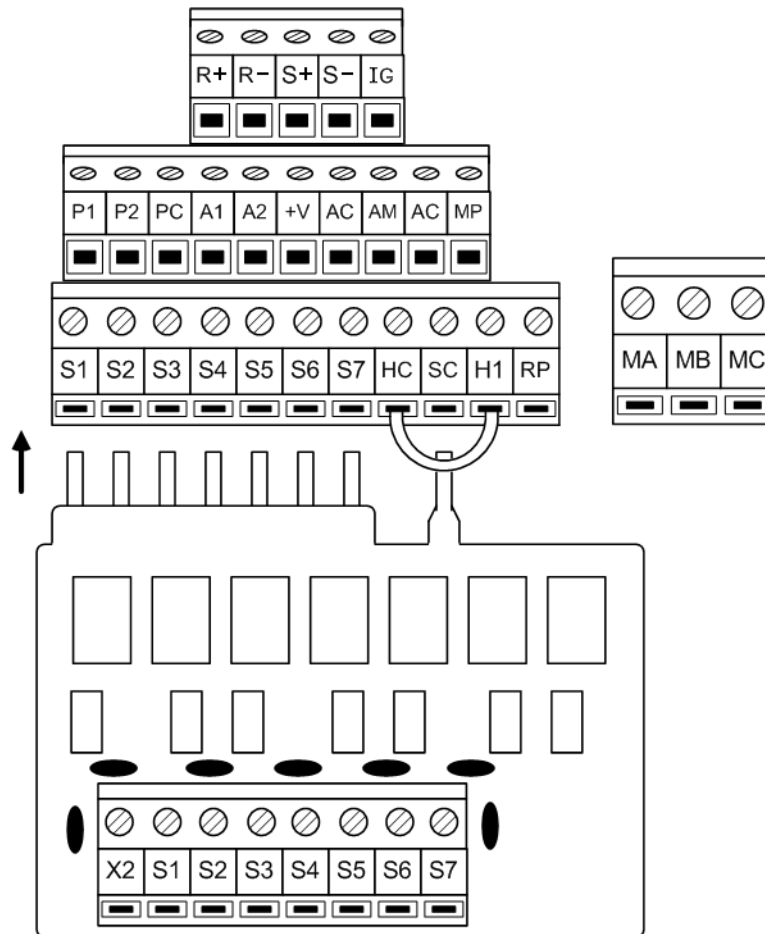

**Figure 3-3: Grounding**

## Wiring the Control Circuit

### Control Circuit Terminals

The IMPULSE•G+ Mini is shipped with a 120V interface card, allowing direct connection of 120V user input devices. The interface card connects to drive terminals S1-S7 and SC. The user input device then connects to terminals S1-S7 and X2 on the interface card. Terminals S1 and S2 are factory programmed for the forward (up) and reverse (down) run commands; however, they can be programmed for speed control and other functions like the remaining terminals. The figure below shows the control terminal arrangement for the IMPULSE•G+ Mini along with the 120V interface card (G+M IF 120V).



**120V Interface Card**

**Figure 3-4: IMPULSE•G+ Mini 120V Interface Card**

## Control Board DIP Switches

There are three switch settings on the controller board that are used for controller input (S1 - S7) polarity, analog input signal control method, and RS485 termination. The figure below shows the location of these switches and their function along with the default settings.

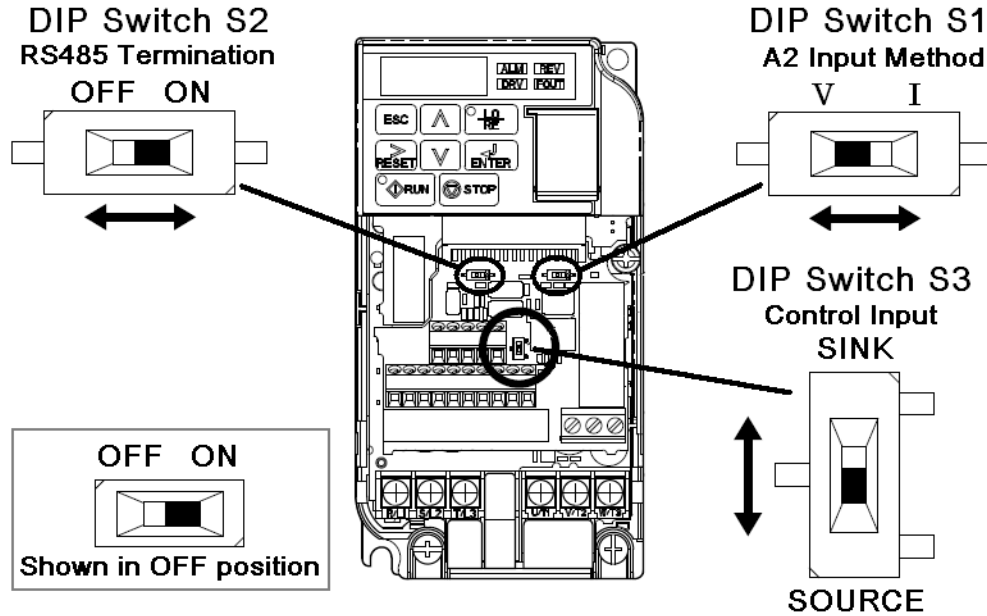

Figure 3-5: DIP Switches

Name	Function	Settings
DIP Switch 1	Input method for analog input A2	V: 0–10VDC input (internal resistance: 20K Ohm) I: 4–20 mA input (internal resistance 250 Ohm) ( <b>Default</b> )
DIP Switch 2	RS485 Termination	<b>OFF</b> : No terminating resistance ( <b>Default</b> ) <b>ON</b> : Terminating resistance of 110 Ohm
DIP Switch 3	Controller input signal polarity (S1-S7) on the controller board	<b>SINK</b> : Must remain in this position for use with the 120VAC and 24VAC interface cards ( <b>Default</b> ) <b>SOURCE</b> : Consult Factory

## IMPULSE•G+ Mini Optional Relay Outputs

The interface card P3S2-OUT2 provides two 240 VAC, 1.5 Amp rated solid-state relay outputs. Each relay is independently programmable. Constants H02.02 and H02.03 will configure these digital outputs.

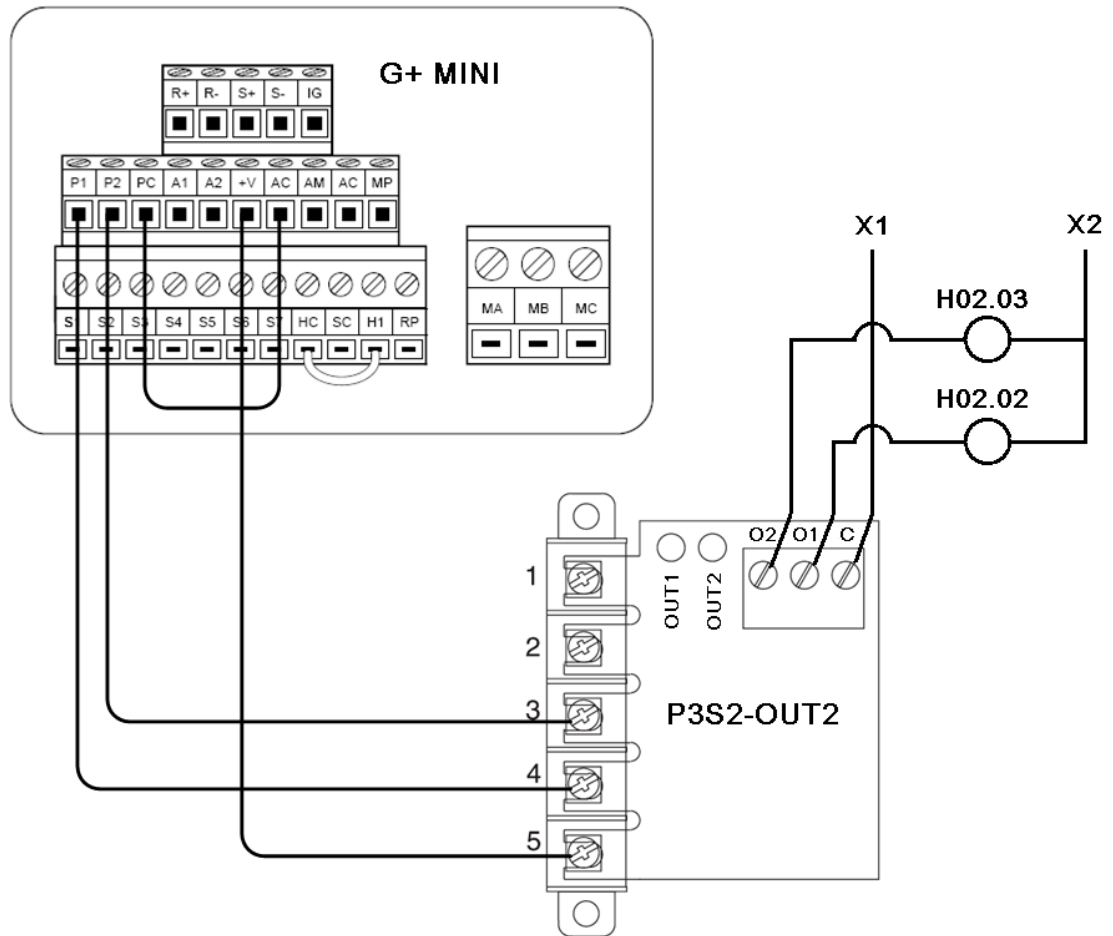
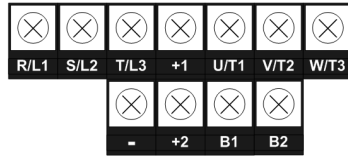

Figure 3-6: IMPULSE•G+ Mini Output Card

## IMPULSE•G+ Mini Power Terminal Arrangement

230V	Arrangement	460V	Arrangement
2001-G+M	1	4001-G+M	2
2003-G+M	1	4002-G+M	2
2005-G+M	1	4003-G+M	2
2008-G+M	2	4004-G+M	2
2011-G+M	2	4009-G+M	2
2017-G+M	2	4014-G+M	3
2025-G+M	3	4018-G+M	3
2033-G+M	3	4024-G+M	4
2047-G+M	4	4031-G+M	4
2060-G+M	5	--	--



Arrangement 1

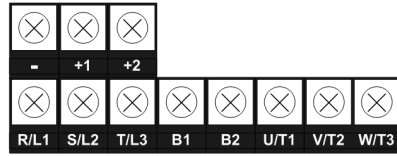

Arrangement 2

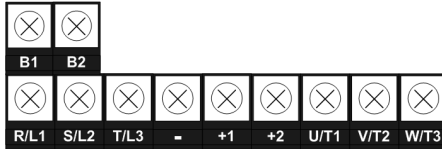

Arrangement 3

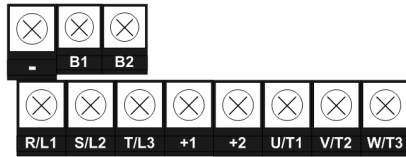

Arrangement 4

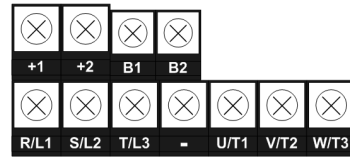

Arrangement 5

Figure 3-7: IMPULSE•G+ Mini Power Terminal Arrangement

This page intentionally left blank.

# *Chapter* **4**

## **Getting Started**

This page intentionally left blank.



# Overview

With its easy-to-use keypad and X-Press Programming™ feature, the IMPULSE•G+ Mini makes it easy to get up and running right away. This chapter explains how to navigate through the drive's menus along with the function and meaning of each button and indicator. The keypad makes it possible to view fault codes and change parameter settings. The keypad enables you to:

- Program the various drive parameters.
- Monitor the functions of the drive.
- Read fault-diagnostic indications.
- Operate the drive using the keypad (local operation).



## WARNING

Because of the additional potential hazards that are introduced when any drive is operated locally, we advise you to avoid operating it this way. If you do operate the drive locally, be aware that the crane or hoist will move when you press the RUN button. If you have questions, contact Magnetek.

## Checks Before Powering

After mounting and interconnections are completed, verify:

- Correct connections.
- Correct input power supply (no voltage drop or imbalance, source kVA  $\leq$  500, unless a line reactor is used). If unsure of the source transformer, use a line reactor.



## WARNING

*DO NOT power 230V-rated drives with 460V power.*

- No short circuit conditions.
- No loose screw terminals (check especially for loose wire clippings).
- Proper load conditions.

## Precautions

- Only start the motor if motor shaft rotation is stopped.
- Even with small loading, never use a motor whose nameplate amperage exceeds the inverter rated current.



## DANGER

*Extreme caution should be used if braking method is set to decelerate to stop. If deceleration time is too long, equipment could run into end stop device, causing damage to equipment or injury to personnel.*

# Using the Keypad

All functions of the drive are accessed using the keypad. The operator can enter information using the keypad to configure the drive for their application. This information will be stored in the drive's memory.

## Keypad Functions

The keypad has a 5-digit LED alpha-numeric display.

Indicators and keys on the keypad are described in Figure 4-1 and the following tables.

*NOTE: The STOP key is always active and will immediately cause the motor to stop, following the B03.03 stopping method.*

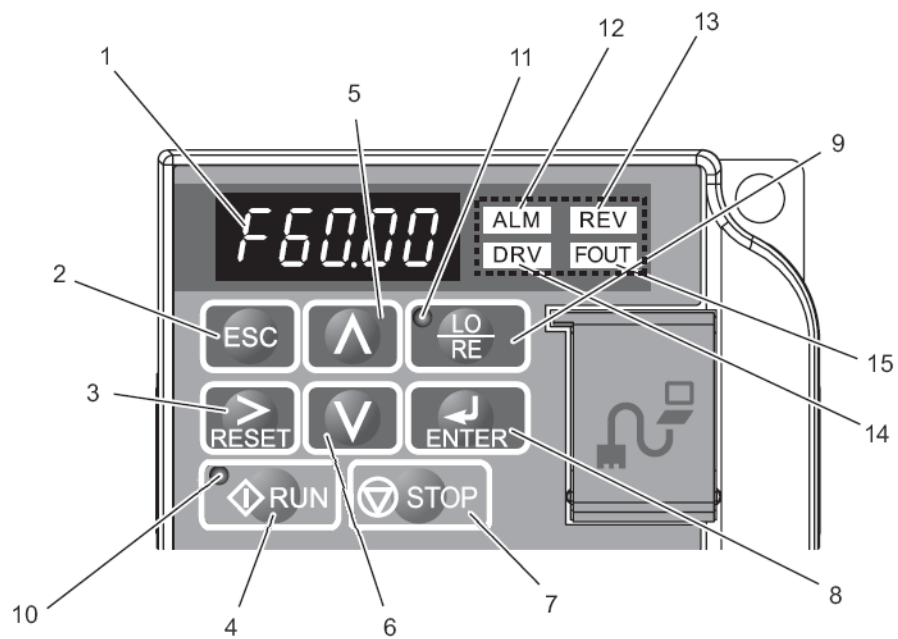







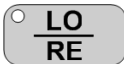

**Figure 4.1: Keypad Display**



## Keypad LED and Button Functions

Some of the keypad buttons, whose functions are described below, are dual-purpose. The dual-purpose keys have one function when used in a view-only mode, and another function when used in a programming mode.





### Keys and Displays on the LED Operator

No.	Display	Name	Function
1		Data Display Area	Displays the frequency reference, parameter number, etc.
2		ESC Key	Returns to the previous menu (before ENTER Key is pressed), or cursor position.
3		RESET Key	Moves the cursor to the right. Resets the drive to clear a fault situation.
4		RUN Key	Pressing the key initiates the RUN command when LOCAL mode operation is selected. Starts the auto-tuning process.
5		Up Arrow Key	Scrolls up to select the next parameter group or parameter settings. It also increases the value of the blinking digit of a parameter setting.
6		Down Arrow Key	Scrolls down to select the next parameter group or parameter settings. It also decreases the value of the blinking digit of a parameter setting.
7		STOP Key	Stops the drive by initiating a base block STOP command.
8		ENTER Key	Selects modes or parameters. Displays each parameter's set value. By pressing this key again, the set value is stored.
9		LO/RE Selection Key	Pressing the key once displays support phone number 866-624-7378. Pressing the key again shows control method, motion, and reference speed. Pressing the key again will show RESET. Pressing the ENTER Key afterwards will reset the maintenance timers.

## LO/RE LED and RUN LED Indications

No.	LED	Lit	Flashing	Flashing Quickly	Off
10		During run.	During deceleration to stop. When a run command is input and frequency reference is 0.	During deceleration at a fast-stop. During stop by interlock operation.	During stop.
11		When run command is selected from LED operator (LOCAL).	--	--	Run command is selected from device other than LED operator (REMOTE).

## Function LEDs

No.	Display	Lit	Flashing	Off
12		When the drive detects an alarm or error	When an alarm occurs OPE detected When a fault or error occurs during Auto-Tuning	Normal state (no fault or alarm)
13		When the REVERSE command is given	--	When the FORWARD command is given
14		Drive Ready Auto-Tuning	--	Programming Mode
15		Displays output frequency (Hz)	--	--

## Quick Start Guide Information

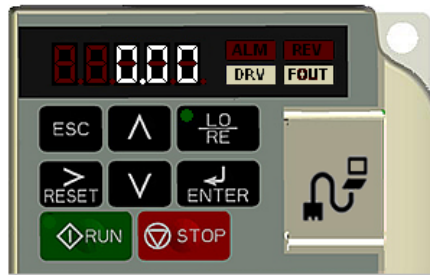

Basic programming of the drive consists of entering motor parameters, choosing a motion, and selecting a speed reference.

After applying power to the drive, the display will show the output frequency of 0.00.





### Navigation Keys:

The above figure shows the keypad on the G+ Mini. These keys are used for navigation and for changing various settings within the drive.

Use the  and  keys to change the display and/or change the value of a parameter.

Use the  key to move the cursor to the right and to reset the drive after a fault.

Use the  key to view and save any parameter changes or the  key to exit without saving changes.

### Setting Motion:

From the output frequency display, press the  key five times until the display shows the parameter menu (PAr).



Press . The display will show A01.01.

Press  two times to move the blinking digit to the right.

Press  until the parameter A01.03 (Motion) appears.

Press .

Use the following table to select the desired motor for your application:

A01.03 - Motion	
Data Value	Function
00	Traverse
01	Hoist (Default)

Use the , , and  keys to change the value.

Press  to save your changes. The display will temporarily show **End**, then A01.03.

#### Setting Speed Reference:

Press the  key to navigate to A01.04 (Speed Reference), press .

Use the following table to select the speed reference for your application:



A01.04 - Speed Reference	
Data Value	Function
00	2-speed Multi-Step
01	3-speed Multi-Step (Default)
02	5-speed Multi-Step
03	2-step Infinitely Variable
04	3-step Infinitely Variable
05	Uni-Polar Analog (0-10 VDC or 4-20mA)

Use the , , and  keys to change the value.

Press  to save your changes. The display will temporarily show **End**, then A01.04



## Setting Motor Full Load Amps:

Locate the nameplate on your motor to find the Full Load Amps (FLA), and the motor RPM.

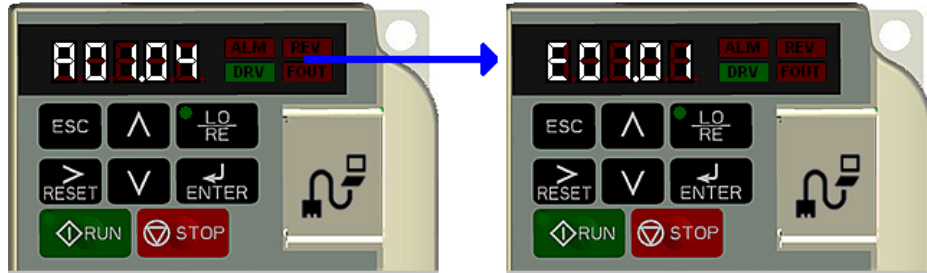

Press the  key once to move the cursor to the left most spot. Use the  and  keys to navigate to the “E” menu. The display should show E01.01.





Press the  key once to move the blinking digit to the right.

Press the  key once to change from E01 to E02. The display now shows E02.01 (Motor FLA). Press  twice.

*NOTE: If more than one motor is being controlled by the drive, enter in the total of all the motor full load amp ratings. This step is important to provide proper motor overload protection.*

Use the , , and  keys to enter the FLA from the motor nameplate.

Press  to save your changes. The display will temporarily show , then E02.01.

Press  four times to return to the frequency reference display.



Your drive is now ready.

## Parameters

The parameters are organized by function group, that determine how the drive functions. These parameters are programmed in the drive's software as measurable values or options—both of which will be referred to in this manual as *settings*. While some of these parameters are associated with one setting, others are tied to a number of possible settings.

*NOTE:* The terms “constant” and “parameter” have the same meaning.

By default, the IMPULSE•G+ Mini is configured for a common crane system. If you find it necessary to change the initial settings, it is recommended that you only allow qualified crane system technicians to program the drive. This can be accomplished by using the Password and Access Level features. For more information on these security features, see page 4-14.



## **Parameter Modes**

All parameters are organized under four modes:

### **Operation Mode**

Drive operation is enabled. Drive status LED lights.

### **Programming Mode**

Parameter access levels, control method, motion, speed control mode, and passwords are selected. Parameters are set/read. Items to be set/read vary depending on the access level setting.

### **Auto-Tuning Mode**

Motor parameters are automatically set by entering tuning data (motor nameplate values) when using V/f or OLV control method.

### **Verify Constants Mode**

Only parameters that have been changed from the factory default settings are shown here. They can be set/read.

## IMPULSE•G+ Mini Structure of Parameters

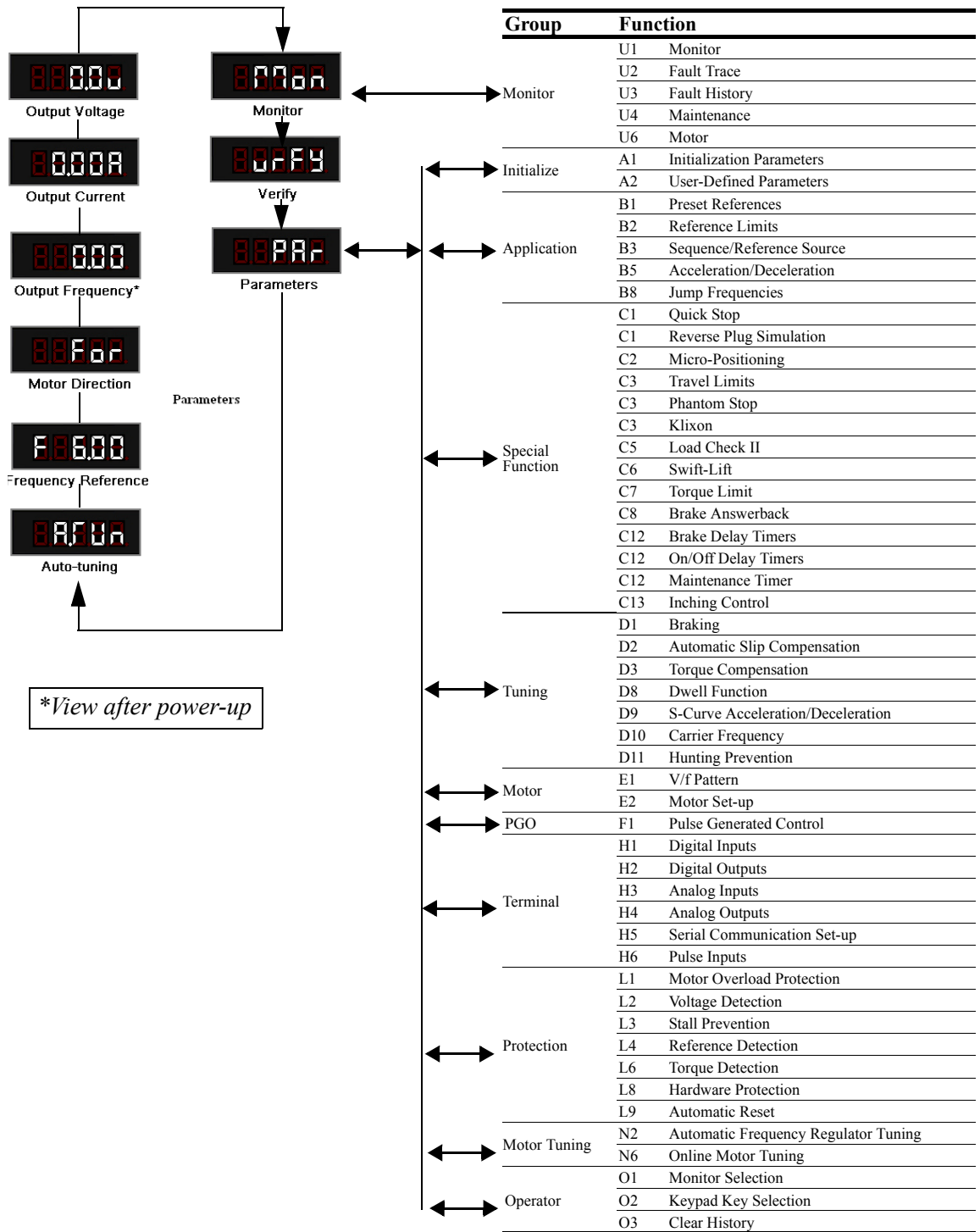

## Initialization Set-up

### Parameter Access Level (A01.01)

This parameter controls the level of access for all the parameters in the drive. Using this parameter controls the “masking” of parameters according to the access level selected. There are three access levels available - BASIC, ADVANCED and USER. When the access level is set to ADVANCED (A01.01 = 0002), it will allow access to all parameters outlined in this manual.

Changing the access level to USER (A01.01 = 0000) limits access to only parameters stored in the A02.xx table (up to 32). To set up the A02.xx group, refer to page 4-14.

Setting	Description
0000	User Program - Allows read/write capabilities for parameters selected by OEM (A02.01 to A02.32).
0001	Basic Level - Access to parameters for general crane applications.
0002	Advanced Level - for advanced programming in special applications.

### Control Method Selection (A01.02)

Select the control method best suited for your application.

Setting	Description	Access Level
00	V/f Control—For general purpose and multiple motor applications.	Basic/Adv
02	OLV—Open Loop Vector; for applications requiring precise speed control, quick response and higher torque at low speeds (150% torque below 1 Hz).	Adv

*NOTE: An auto-tune must be performed for all open loop vector applications. Refer to the Auto-Tuning section on page 4-15.*

### Select Motion (A01.03)

Set this parameter to match the motion of application. See tables 4.1 and 4.2 (X-Press Programming) for details.

Setting	Description	Access Level
00	Traverse - Decelerate to stop upon removal of RUN command.	Basic/Adv
01	Standard Hoist - Immediate stop upon removal of RUN command	Basic/Adv
04	Braketronic	Adv

### Speed Reference (A01.04)

This parameter will automatically define the input terminals for the selections listed below. See tables 4.1 and 4.2 (X-Press Programming) for details.

Setting	Description	Access Level
00	2-SPD Multi-step — Defines Terminal S3 = 2nd speed.	Basic/Adv
01	3-SPD multi-step — Defines Terminals S3 and S4 as speeds 2 and 3 respectively.	Basic/Adv
02	5-SPD Multi-step — Defines Terminals S3-6 as speeds 2-5.	Basic/Adv
03	2-Step infinitely variable — Terminals S1 and S2 = B01.01 (Reference 1) and speed hold. Terminal S3 = Accelerate.	Basic/Adv
04	3-Step infinitely variable — Terminals S1 and S2 = B01.01 (Reference 1). Terminal S3 = Speed Hold. Terminal S4 = Accelerate.	Basic/Adv
05	Uni-polar analog — Terminals S1 and S2 = A directional input. Terminal A1 = 0-10V. Terminal A2 = 4-20mA for speed reference.	Basic/Adv

## Parameters Changed by X-Press Programming

**Table 4-1: Traverse (A01.03= 00)**

A01.04	Description	B01.01	B01.02	B01.03	B01.04	B01.05	B01.17	B01.18	B02.03	B03.03	B05.01	B05.02
		Speed 1	Speed 2	Speed 3	Speed 4	Speed 5	Jog Ref	Ref Priority	Ref. Lower Limit	Stopping Method	Accel Time 1	Decel Time 1
00	2-Speed Multi-Step	6.00	60.00	0.00	0.00	0.00	6.00	00	2.0	00	5.0	5.0
01	3-Speed Multi-Step	6.00	30.00	60.00	0.00	0.00	6.00	00	2.0	00	5.0	5.0
02	5-Speed Multi-Step	6.00	15.00	30.00	45.00	60.00	6.00	00	2.0	00	5.0	5.0
03	2-Step Infinitely Variable	6.00	0.00	0.00	0.00	60.00	6.00	00	2.0	00	5.0	5.0
04	3-Step Infinitely Variable	6.00	0.00	0.00	0.00	60.00	6.00	00	2.0	00	5.0	5.0
05	Uni-Polar Analog	0.00	0.00	0.00	0.00	0.00	6.00	01	2.0	00	5.0	5.0

A01.04	Description	C01.01	D09.01	D09.02	D09.03	E01.03	H01.01	H01.02	H01.03	H01.04	H01.05	H01.06	H01.07	H02.01	H02.02	H02.03	H03.01	N02.05
		Quick Stop	S-Curve Accel at Start	S-Curve Accel at End	S-Curve Decel at Start	V/f Selection	Terminal S1 Select	Terminal S2 Select	Terminal S3 Select	Terminal S4 Select	Terminal S5 Select	Terminal S6 Select	Terminal S7 Select	Terminal MA/MB/MC Select	Terminal P1 Select	Terminal P2 Select	Terminal A1 Signal	OLV Stab. Level
00	2-Speed Multi-Step	00	1.50	1.50	1.50	01	80	81	00	0F	0F	0F	0F	00	0F	0F	00	00
01	3-Speed Multi-Step	00	1.50	1.50	1.50	01	80	81	00	01	0F	0F	0F	00	0F	0F	00	00
02	5-Speed Multi-Step	00	1.50	1.50	1.50	01	80	81	00	01	02	03	0F	00	0F	0F	00	00
03	2-Step Infinitely Variable	00	1.50	1.50	1.50	01	80	81	05	0F	0F	0F	0F	00	0F	0F	00	00
04	3-Step Infinitely Variable	00	1.50	1.50	1.50	01	80	81	04	05	0F	0F	0F	00	0F	0F	00	00
05	Uni-Polar Analog	00	1.50	1.50	1.50	01	80	81	0F	0F	0F	0F	0F	00	0F	0F	00	00

## Parameters Changed by X-Press Programming

**Table 4-2: Standard Hoist (A01.03 = 01)**

A01.04	Description	B01.01	B01.02	B01.03	B01.04	B01.05	B01.17	B01.18	B02.03	B03.03	B05.01	B05.02
		Speed 1	Speed 2	Speed 3	Speed 4	Speed 5	Jog Ref	Ref Priority	Ref. Lower Limit	Stopping Method	Accel Time 1	Decel Time 1
00	2-Speed Multi-Step	6.00	60.00	0.00	0.00	0.00	6.00	00	2.0	01	5.0	3.0
01	3-Speed Multi-Step	6.00	30.00	60.00	0.00	0.00	6.00	00	2.0	01	5.0	3.0
02	5-Speed Multi-Step	6.00	15.00	30.00	45.00	60.00	6.00	00	2.0	01	5.0	3.0
03	2-Step Infinitely Variable	6.00	0.00	0.00	0.00	60.00	6.00	00	2.0	01	5.0	3.0
04	3-Step Infinitely Variable	6.00	0.00	0.00	0.00	60.00	6.00	00	2.0	01	5.0	3.0
05	Uni-Polar Analog	0.00	0.00	0.00	0.00	0.00	6.00	01	2.0	01	5.0	3.0

A01.04	Description	C01.01	D09.01	D09.02	D09.03	E01.03	H01.01	H01.02	H01.03	H01.04	H01.05	H01.06	H01.07	H02.01	H02.02	H02.03	H03.01	N02.05
		Quick Stop	S-Curve Accel at Start	S-Curve Accel at End	S-Curve Decel at Start	V/f Selection	Terminal S1 Select	Terminal S2 Select	Terminal S3 Select	Terminal S4 Select	Terminal S5 Select	Terminal S6 Select	Terminal S7 Select	Terminal MA/MB/MC Select	Terminal P1 Select	Terminal P2 Select	Terminal A1 Signal	OLV Stab. Level
00	2-Speed Multi-Step	00	0.50	0.50	0.50	04	80	81	00	0F	0F	0F	0F	00	0F	0F	00	00
01	3-Speed Multi-Step	00	0.50	0.50	0.50	04	80	81	00	01	0F	0F	0F	00	0F	0F	00	00
02	5-Speed Multi-Step	00	0.50	0.50	0.50	04	80	81	00	01	02	03	0F	00	0F	0F	00	00
03	2-Step Infinitely Variable	00	0.50	0.50	0.50	04	80	81	05	0F	0F	0F	0F	00	0F	0F	00	00
04	3-Step Infinitely Variable	00	0.50	0.50	0.50	04	80	81	04	05	0F	0F	0F	00	0F	0F	00	00
05	Uni-Polar Analog	00	0.50	0.50	0.50	04	80	81	0F	0F	0F	0F	0F	00	0F	0F	00	00

## Parameters Changed by X-Press Programming

**Table 4-3: Braketronic (A01.03 = 04)**

A01.04	Description	B01.01	B01.02	B01.03	B01.04	B01.05	B01.17	B01.18	B02.03	B03.03	B05.01	B05.02
		Speed 1	Speed 2	Speed 3	Speed 4	Speed 5	Jog Ref	Ref Priority	Ref. Lower Limit	Stopping Method	Accel Time 1	Decel Time 1
00	2-Speed Multi-Step	6.00	60.00	0.00	0.00	0.00	6.00	02	2.0	00	1.0	1.0
01	3-Speed Multi-Step	6.00	30.00	60.00	0.00	0.00	6.00	02	2.0	00	1.0	1.0
02	5-Speed Multi-Step	6.00	15.00	30.00	45.00	60.00	6.00	02	2.0	00	1.0	1.0
03	2-Step Infinitely Variable	6.00	0.00	0.00	0.00	60.00	6.00	02	2.0	00	1.0	1.0
04	3-Step Infinitely Variable	6.00	0.00	0.00	0.00	60.00	6.00	02	2.0	00	1.0	1.0
05	Uni-Polar Analog	0.00	0.00	0.00	0.00	0.00	6.00	02	2.0	00	1.0	1.0

A01.04	Description	C01.01	D09.01	D09.02	D09.03	E01.03	H01.01	H01.02	H01.03	H01.04	H01.05	H01.06	H01.07	H02.01	H02.02	H02.03	H03.01	N02.05
		Quick Stop	S-Curve Accel at Start	S-Curve Accel at End	S-Curve Decel at Start	V/f Selection	Terminal S1 Select	Terminal S2 Select	Terminal S3 Select	Terminal S4 Select	Terminal S5 Select	Terminal S6 Select	Terminal S7 Select	Terminal MA/MB/MC Select	Terminal P1 Select	Terminal P2 Select	Terminal A1 Signal	OLV Stab. Level
00	2-Speed Multi-Step	00	0.00	0.00	0.00	00	80	81	00	0F	0F	0F	65	0F	0F	0F	00	00
01	3-Speed Multi-Step	00	0.00	0.00	0.00	00	80	81	00	01	0F	0F	65	0F	0F	0F	00	00
02	5-Speed Multi-Step	00	0.00	0.00	0.00	00	80	81	00	01	02	03	65	0F	0F	0F	00	00
03	2-Step Infinitely Variable	00	0.00	0.00	0.00	00	80	81	05	0F	0F	0F	65	0F	0F	0F	00	00
04	3-Step Infinitely Variable	00	0.00	0.00	0.00	00	80	81	04	05	0F	0F	65	0F	0F	0F	00	00
05	Uni-Polar Analog	00	0.00	0.00	0.00	00	80	81	0F	0F	0F	0F	65	0F	0F	0F	00	00

## Initialize Parameters (A01.05)

Use this parameter to reset the drive to user-specified initial values or clear an oPE04 fault.

Setting	Description
0000	No Initialize (factory default)
1110	User Initialize - Restores the drive to user-specified initial values.
5550	Copies save parameters back from terminal to the drive's memory

### User Initialize (A01.05 = 1110)

Once the drive is configured and the system is running, set parameter O02.03 = 01 to save all modified parameters to the User Initialized memory on the terminal board. Changing A01.05 = 1110 will recall all modified parameters back to the last time saved using O02.03.

### oPE04 Fault (A01.05 = 5550)

The oPE04 fault indicates the parameters in the terminal board do not match the parameters of the control board. To reset the oPE04 fault, set A01.05 = 5550. This will copy the parameters from the terminal board to the control board. Check and verify your kVA setting (O02.04) before operating the drive. Please contact Magnetek support for assistance.

## Password Entry 1 (A01.06)

This parameter enables the user to set a password that inhibits the programming of parameters A01.01 ~ A01.08 and locks the remaining parameters in the drive except those stored in the User Parameter group, A02.xx.

To program a password, access the programming menu, "PAR", and navigate to parameter A01.06. Press the STOP and UP arrow keys at the same time to change the display from A01.06 to A01.07. Press ENTER and program a password number into A01.07.

When parameters A01.06 ≠ A01.07, only parameters A01.01, A01.06, and A01.08 are visible and cannot be modified. The Access Level is set to User Program (A01.01 = 0000). Parameters programmed in A02.xx can be viewed in the "USER" menu with read/write accessibility. When A01.06 = A01.07, then A01.01 to A01.08 can be modified, along with the remaining parameters in the drive.

When A01.06 ≠ A01.07, then A01.06 will show "LoC". When A01.06 = A01.07, then A01.06 will show "UnLoC".

## User Parameters (A02.01 through A02.32)

This function allows users to select up to 32 parameters for quick-access programming in the "USER" menu when the access level is set to User Program (A01.01 = 0000). This function is useful when used in conjunction with A01.06, which locks all parameters in the drive except those stored in the User Parameter Group, A02.xx.

To assign a parameter as a user parameter, change the Access Level to Advanced (A01.01 = 0002), go to the A02 function group and select an A02.01 ~ A02.32 parameter. Press ENTER. The display will show "----". Use the UP or DOWN arrow keys to select a user parameter and press ENTER when done.



To clear a parameter stored in the A02.xx, change the value to “----”. Change the Access Level to User Program (A01.01 = 0000).

### **Password Entry 2 (A01.08)**

Used to access OEM specific crane and hoist functions.

# Auto-Tuning

The IMPULSE•G+ Mini can adapt to all motors manufactured world wide with its automatic tuning function. The drive asks the user for minimal motor information, and then guides them through a quick, simple tuning process. Ideally, perform a rotational Auto-Tune with the motor uncoupled from the load. When the motor cannot be disconnected from the load, perform a stationary or non-rotating Auto-Tune.

*NOTE: Contact Magnetek Inc. Service Department if an Auto-Tune can not be performed.*



## CAUTION

The brake output is not energized during Auto-Tune. The brake must be manually released before Auto-Tuning and unreleased when Auto-Tuning is complete.

The IMPULSE•G+ Mini can perform both a stationary and rotational Auto-Tune in the Advanced Mode. For optimal performance, a rotational Auto-Tune should be performed.

Parameter Code	Name	Description	Range	Initial Value	Access Level
T01.01	Tuning Mode Select 00: Standard Auto-Tuning (Rotational for OLV) 02: Stationary Auto-Tuning for Line-to-Line resistance	Selects Tuning Method	00, 02	02	Basic/Adv
T01.02	Motor Output Power	Sets the motor size in HP (note: kW = HP x 0.746)	Model Dependent	--	Basic/Adv
T01.03	Motor Rated Voltage	Sets motor rated voltage in VAC	Model Dependent	--	Adv
T01.04	Motor Rated Current	Sets motor rated current in Amps	Model Dependent	--	Basic/Adv
T01.06	Number of Poles	Sets the number of motor poles	02–48	04	Adv
T01.07	Rated Speed	Sets the motor rated speed in RPM	0–24000	1750	Adv
T01.11*	Motor Iron Loss	Provides iron loss information for determining Energy Saving coefficient	Model Dependent	--	Adv

*NOTE: \*Provides iron loss for determining Energy Saving coefficient. When power is cycled, the value set to E02.10 will appear (the motor iron loss). If T01.02 is changed, an initial value for the motor capacity will appear that is close to the capacity that was changed.*

## Using Auto-Tuning

With the keypad, use the UP or DOWN arrow keys to show the auto-tuning menu . Press the ENTER key and scroll through the tuning parameters using the UP Arrow key and enter each of the required parameter settings. Press the RUN key to begin the Auto-Tuning process when the display shows the RUN10 or RUN12 message. During the tuning process, the display will flash the RUN10, RUN12 or RUN13 message. When complete the drive will display END, indicating the tuning was successful. Press the ESC key twice to exit. If there is a fault during the tuning process, the drive will display an error message. Refer to the “Faults Display and Corrective Actions at Auto-Tuning” in Chapter 6.

*NOTE: If the STOP key is pressed during tuning or the auto-tuning is interrupted, the motor will coast to stop and the inverter display will show ER-03. The data changed during tuning will revert to its original values.*

This page intentionally left blank.

# *Chapter* **5**

## **Programming Features**

This page intentionally left blank.

# Application

The application parameters control the acceleration and deceleration characteristics, as well as any preset frequencies the system will require for operation. Application parameters included in this section are listed below:

- B1 Preset References
- B2 Reference Limits
- B3 Sequence/Reference Source
- B5 Acceleration/Deceleration
- B8 Jump Frequencies

## Preset Reference

Parameter Code	Name	Function	Range	Initial Value	Access Level
B01.01	Frequency Reference 1	Sets the frequency of Minimum Speed/Speed 1.	0.00–150.00 Hz**	15.00*	Basic/Adv
B01.02	Frequency Reference 2	Sets the Speed 2 frequency.	0.00–150.00 Hz**	30.00*	Basic/Adv
B01.03	Frequency Reference 3	Sets the Speed 3 frequency.	0.00–150.00 Hz**	60.00*	Basic/Adv
B01.04	Frequency Reference 4	Sets the Speed 4 frequency.	0.00–150.00 Hz**	0.00*	Basic/Adv
B01.05	Frequency Reference 5	Sets the Speed 5 frequency.	0.00–150.00 Hz**	0.00*	Basic/Adv
B01.06	Frequency Reference 6	Sets the Speed 6 frequency.	0.00–150.00 Hz**	0.00*	Adv
B01.07	Frequency Reference 7	Sets the Speed 7 frequency.	0.00–150.00 Hz**	0.00*	Adv
B01.08	Frequency Reference 8	Sets the Speed 8 frequency.	0.00–150.00 Hz**	0.00*	Adv
B01.09	Frequency Reference 9	Sets the Speed 9 frequency.	0.00–150.00 Hz**	0.00*	Adv
B01.10	Frequency Reference 10	Sets the Speed 10 frequency.	0.00–150.00 Hz**	0.00*	Adv
B01.11	Frequency Reference 11	Sets the Speed 11 frequency.	0.00–150.00 Hz**	0.00*	Adv
B01.12	Frequency Reference 12	Sets the Speed 12 frequency.	0.00–150.00 Hz**	0.00*	Adv
B01.13	Frequency Reference 13	Sets the Speed 13 frequency.	0.00–150.00 Hz**	0.00*	Adv
B01.14	Frequency Reference 14	Sets the Speed 14 frequency.	0.00–150.00 Hz**	0.00*	Adv
B01.15	Frequency Reference 15	Sets the Speed 15 frequency.	0.00–150.00 Hz**	0.00*	Adv
B01.16	Frequency Reference 16	Sets the Speed 16 frequency.	0.00–150.00 Hz**	0.00*	Adv
B01.17	Jog Reference	Sets the Speed 17 frequency.	0.00–150.00 Hz**	0.00	Adv
B01.18	Reference Priority	Determines whether the digital or analog frequency reference is used.		00*	Basic/Adv
	00 Digital Ref Only				
	01 Analog Ref Only				
	02 Higher Ref Sel				

*NOTE: When using Higher Ref Sel, 2-Step Infinitely Variable should NOT be used for a Speed Reference setting in parameter A01.04. The two functions are not intended to work in conjunction.*

\* Initial value is determined by X-Press Programming (Table 4.1-4.2).

\*\*Maximum frequency above 150 HZ is available, consult Magnetek.

**Table 5-1: Multi-Step Speed Processing by Multi-Function Input (B01.01 ~ B01.16)**

Speed Reference	Forward/Reverse H01.01 = 80 H01.02 = 81	Multi-Step Speed 2 H01.01 ~ .06 = 00	Multi-Step Speed 3 H01.01 ~ .06 = 01	Multi-Step Speed 4 H01.01 ~ .06 = 02	Multi-Step Speed 5 H01.01 ~ .06 = 03	Fwd/Rev Jog-Fwd/ Rev Inch H01.01~06 = 15, 16, 17, 18
STOP	Off	--	--	--	--	Off
B01.01 Speed Ref 1	On	Off	Off	Off	Off	Off
B01.02 Speed Ref 2	On	On	Off	Off	Off	Off
B01.03 Speed Ref 3	On	On	On	Off	Off	Off
B01.04 Speed Ref 4	On	On	On	On	Off	Off
B01.05 Speed Ref 5	On	On	On	On	On	Off
B01.06 Speed Ref 6	On	Off	On	Off	Off	Off
B01.07 Speed Ref 7	On	Off	On	On	Off	Off
B01.08 Speed Ref 8	On	Off	Off	On	Off	Off
B01.09 Speed Ref 9	On	Off	On	On	On	Off
B01.10 Speed Ref 10	On	Off	Off	On	On	Off
B01.11 Speed Ref 11	On	Off	Off	Off	On	Off
B01.12 Speed Ref 12	On	On	Off	Off	On	Off
B01.13 Speed Ref 13	On	On	On	Off	On	Off
B01.14 Speed Ref 14	On	Off	On	Off	On	Off
B01.15 Speed Ref 15	On	On	Off	On	Off	Off
B01.16 Speed Ref 16	On	On	Off	On	On	Off



## Reference Limits

These parameters will limit the frequency range as a percentage of maximum output frequency (E01.04).

An alternate upper limit frequency can be used during operation when a Multi-Function Input (MFI) is set to 59 (Alt F-Ref UpLimit) and the MFI is on. Alternate Upper Limit Frequency = (B02.04) % x (E01.04).

Parameter Code	Name	Function	Range	Initial Value	Access Level
B02.01	Frequency Reference Upper Limit	Sets as a percentage of the maximum output frequency (E01.04), the maximum frequency at which the drive is able to run.	0.0–110%	100.0	Basic/Adv
B02.02	Frequency Reference Lower Limit	Sets as a percentage of the maximum output frequency (E01.04), the minimum master frequency reference only.	0.0–110%	0.0	Basic/Adv
B02.03	Reference 1 Lower limit	Sets as a percentage of the maximum output frequency (E01.04), and determines the minimum frequency the drive is able to run when an analog signal is below this level.	0.0–110%	2.0*	Basic/Adv
B02.04	Alt Upper Limit	Alternate of B02.01 set by MFI=59.	0-110%	100.0	Basic/Adv

\*Initial value set by X-Press programming.

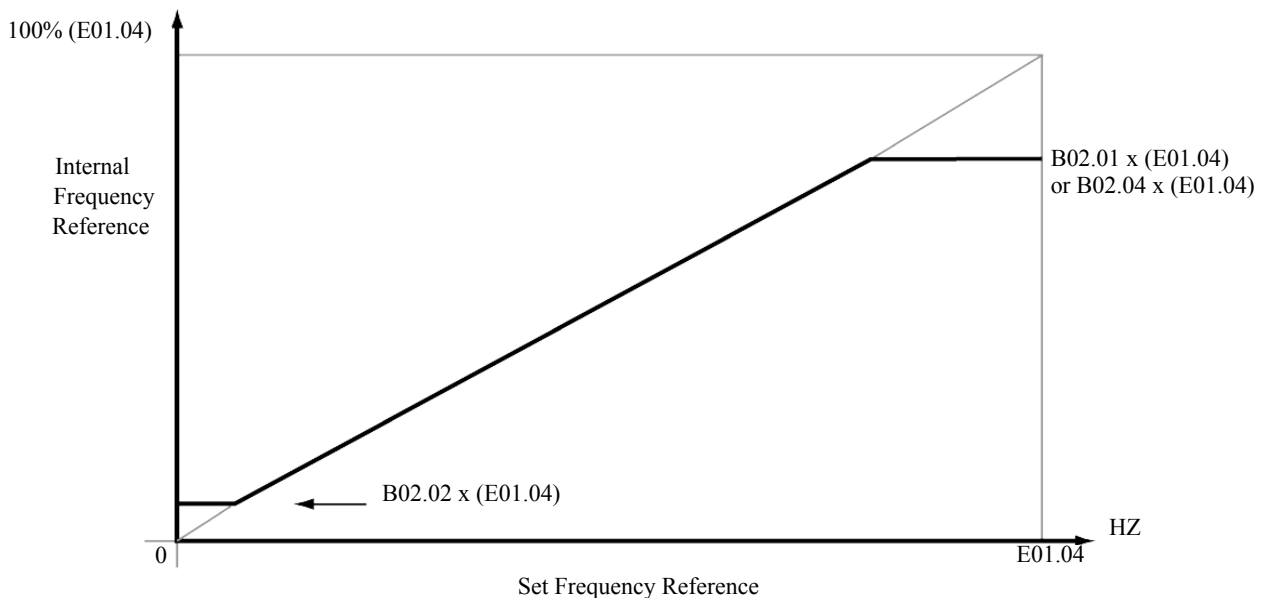

**Figure 5-1: Setting Frequency Upper and Lower Limits**

## Sequence/Reference Source

B03.01 and B03.02 determine the source from where the frequency reference and RUN command are generated.

Parameter Code	Name	Function	Range	Initial Value	Access Level
B03.01	Reference Source	Source from where the frequency reference is generated.	00–02, 04	01	Basic/Adv
	00 <i>Digital Operator</i>	Digital operator (Keypad).			Basic/Adv
	01 <i>Terminal</i>	Control circuit terminal			Basic/Adv
	02 <i>Communication</i>	Memobus Serial Communication			Adv
	04 <i>Pulse Input</i>	Pulse Input			Adv
B03.02	Run Source	Source from where the RUN command is generated.	00–02	01	Basic/Adv
	00 <i>Digital Operator</i>	Digital operator (Keypad).			Basic/Adv
	01 <i>Terminals</i>	Control circuit terminal.			Basic/Adv
	02 <i>Communication</i>	Memobus			Adv



### WARNING

Because of the additional potential hazards that are introduced when any drive is operated locally, we advise you to avoid operating it this way. If you do operate the drive locally, be aware that the crane or hoist will move when you press the RUN button. If you have questions, contact Magnetek.

## Stopping Method

B03.03 selects the stopping method suitable for the particular application.

Parameter Code	Name	Function	Range	Initial Value	Access Level
B03.03	Stop Method	Determines stop method.	00–02, 04	*	Basic/Adv
	00 <i>Decel to Stop (A1-03=0)</i>	Used to stop when motion is traverse (Fig 5-2 & 5-3)			Basic/Adv
	01 <i>Coast to Stop (A1-03=1)</i>	Used to stop when motion is hoist (Fig 5-4 & 5-5)			Basic/Adv
	02 <i>DC Injection</i>	(Fig 5-6 & 5-7)			Adv
	04 <i>Decel w/ Timer (traverse only)</i>	(Fig 5-8, 5-9, & 5-10)			Adv

\* Initial value is determined by X-Press Programming

### Decel to Stop (B03.03 = 00)

Upon removal of the FWD or REV run command, the motor decelerates at a rate determined by the time set in deceleration time 1 (B05.02) and DC injection braking is applied after the DC injection start frequency, D01.01, has been reached. If the deceleration time is set too short or the load inertia is large, an overvoltage fault (OV) may occur during deceleration. In this case, increase the deceleration time or install an optional braking transistor and/or braking resistor.

Braking torque: without braking resistor, approximately 20% of motor rated torque; with braking option, approximately 150% of motor rated torque.

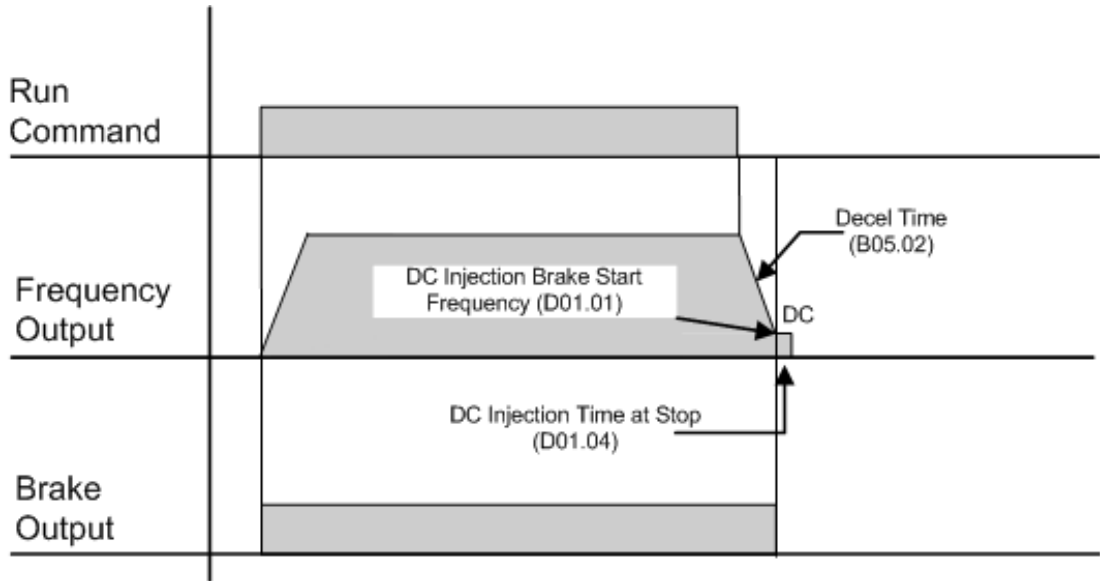

Figure 5-2: B03.03 = 00 (Decel to Stop) without DC Injection

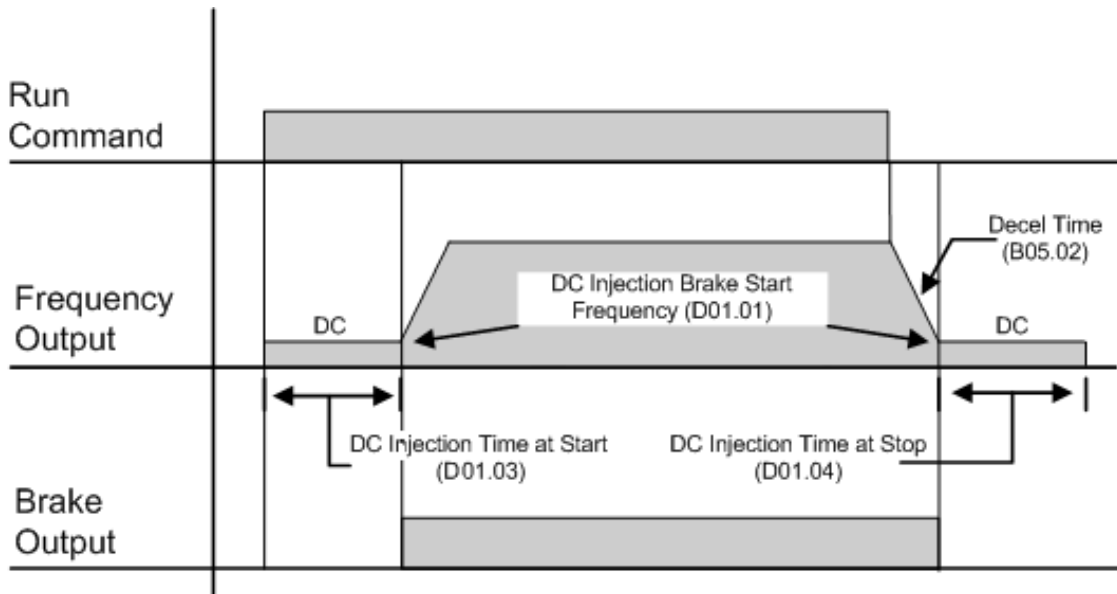
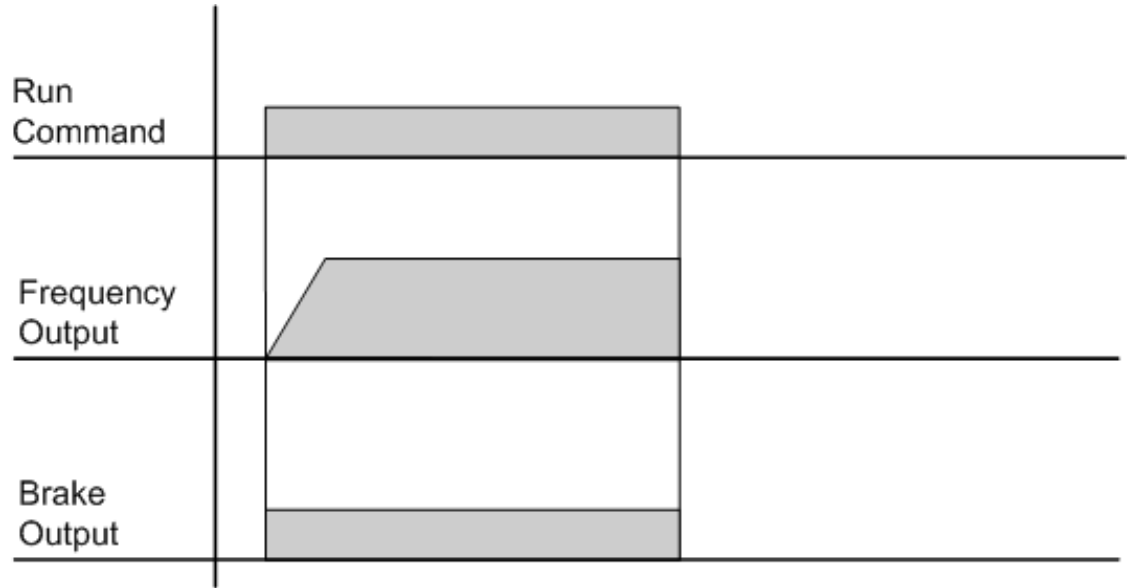

Figure 5-3: B03.03 = 00 (Decel to Stop) with DC Injection

### Coast to Stop (B03.03 = 01)

Upon removal of the FWD or REV run command, the motor starts to coast and the electric brake sets.



*Figure 5-4: B03.03 = 01 (Coast to Stop) without DC Injection*

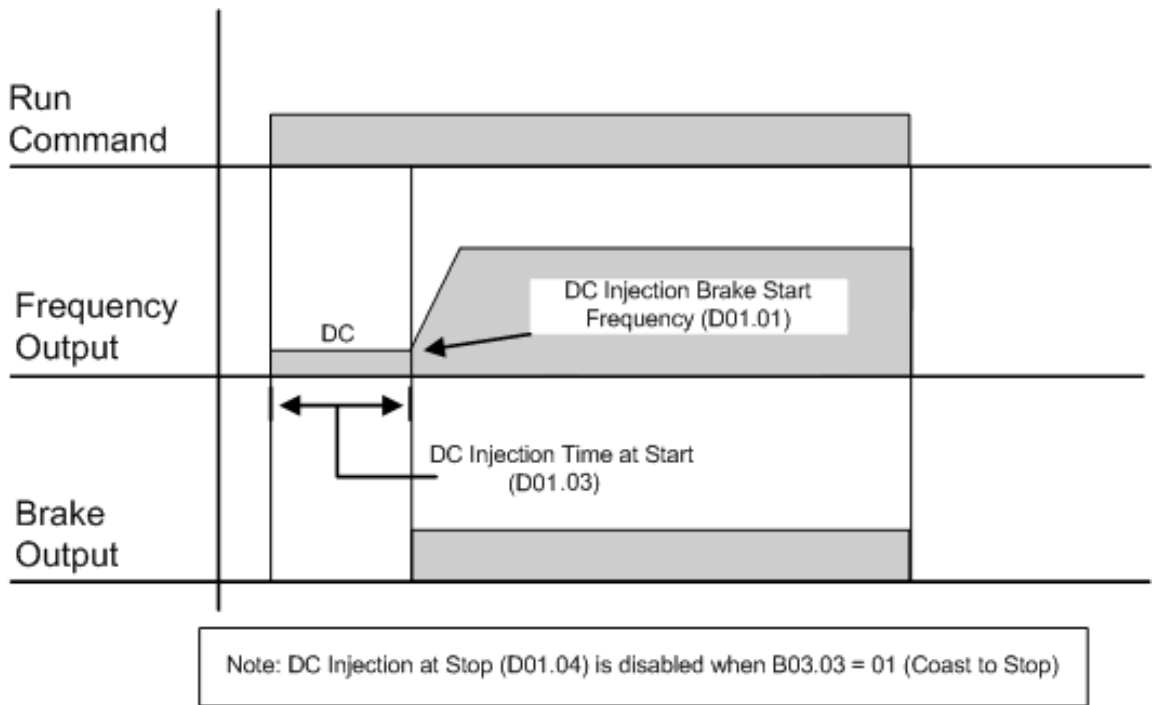

*Figure 5-5: B03.03 = 01 (Coast to Stop) with DC Injection*

DC Injection Braking (B03.03 = 02)

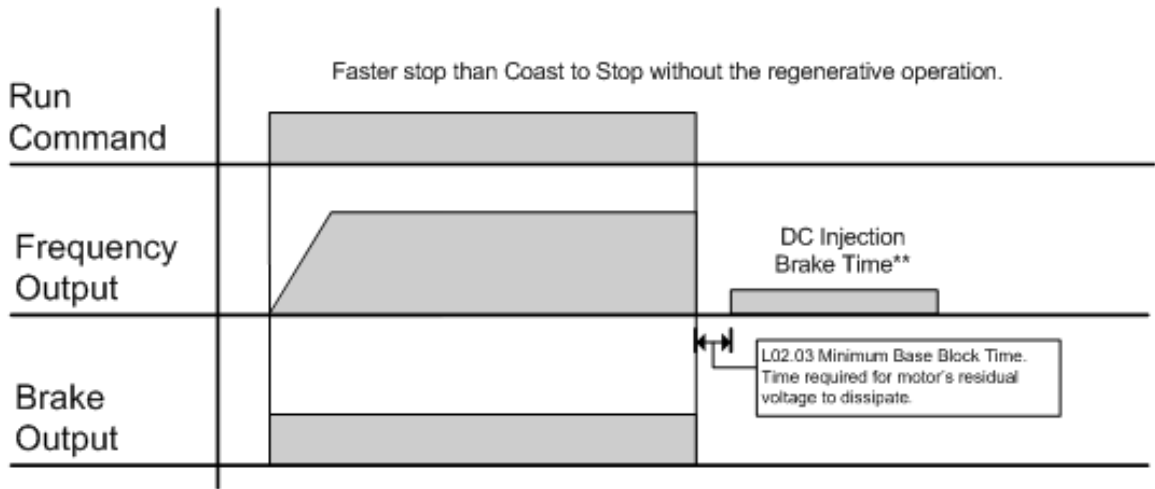

Figure 5-6: B03.03 = 02 (DC Injection at Stop) without DC Injection at Start

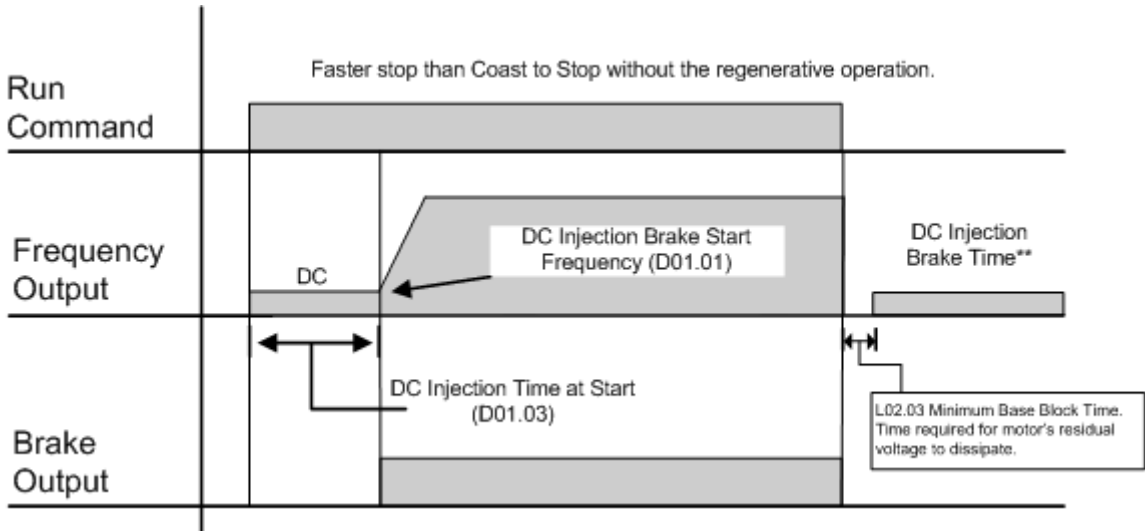
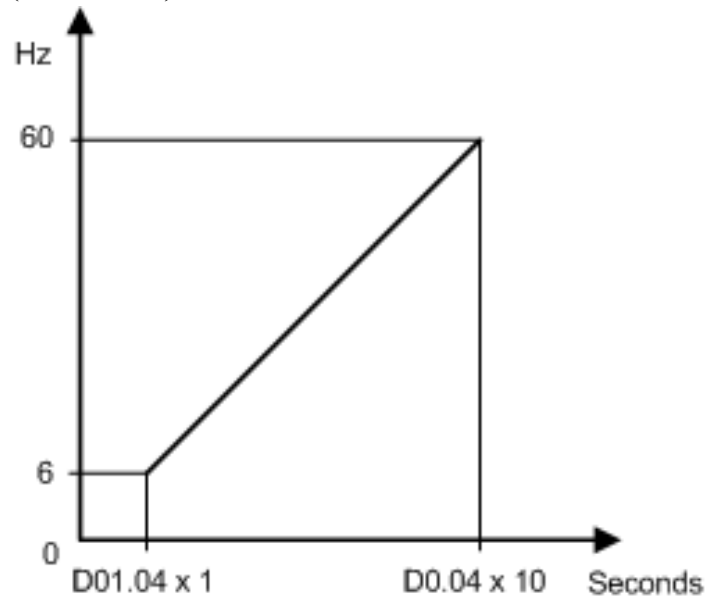
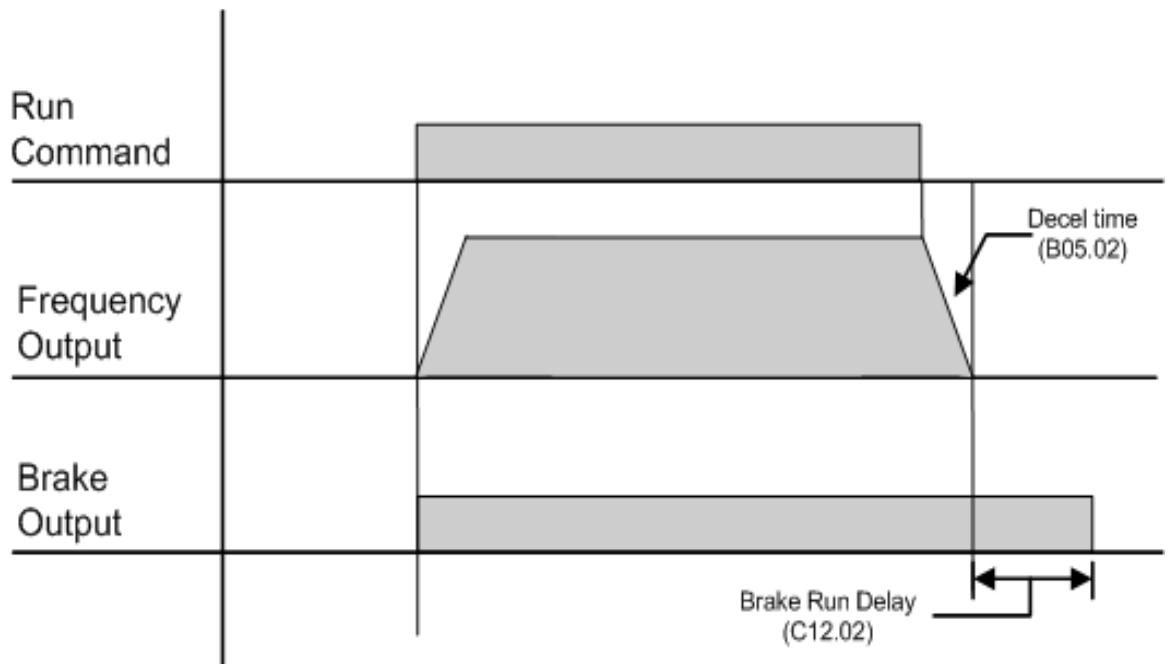

Figure 5-7: B03.03 = 02 (DC Injection at Stop) with DC Injection at Start

**Decel with Timer (B03.03 = 04)**



$$**DC \text{ Injection brake time} = \frac{D01.04 \times 10 \times \text{Output frequency}}{\text{Max. output frequency (E01.04)}}$$



**Figure 5-8: B03.03 = 04 (Decel with timer) without DC Injection**

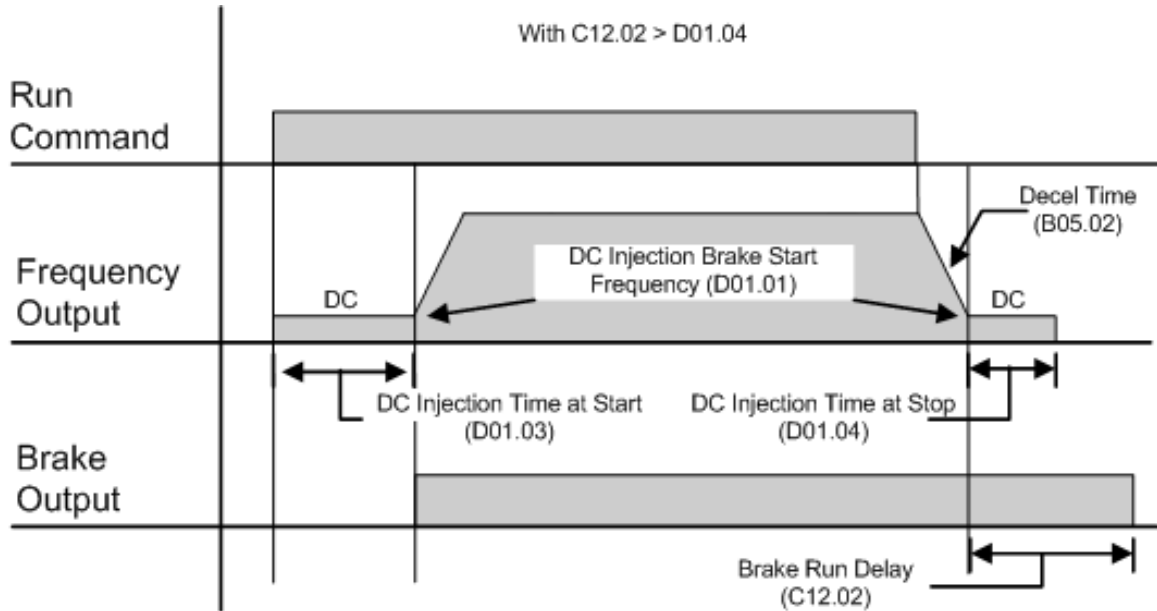

**Figure 5-9: B03.03 = 04 (Decel with timer) with DC Injection, where  $C12.02 > D01.04$**

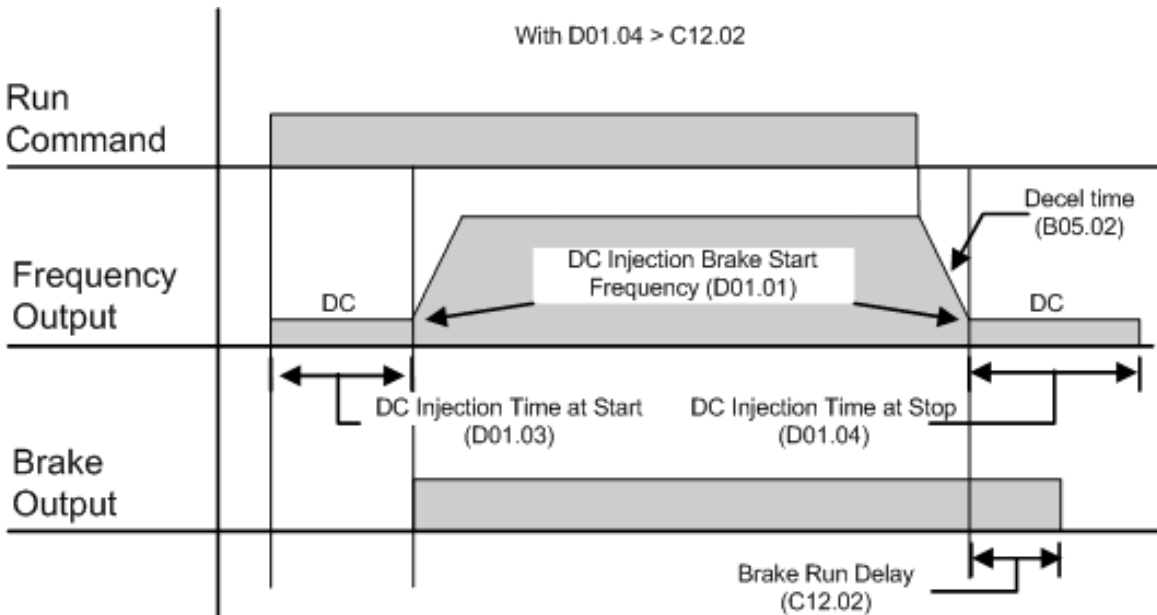

**Figure 5-10: B03.03 = 04 (Decel with timer) without DC Injection, where  $D01.04 > C12.02$**

### Fast Stop (H01.xx = 40 or 42)

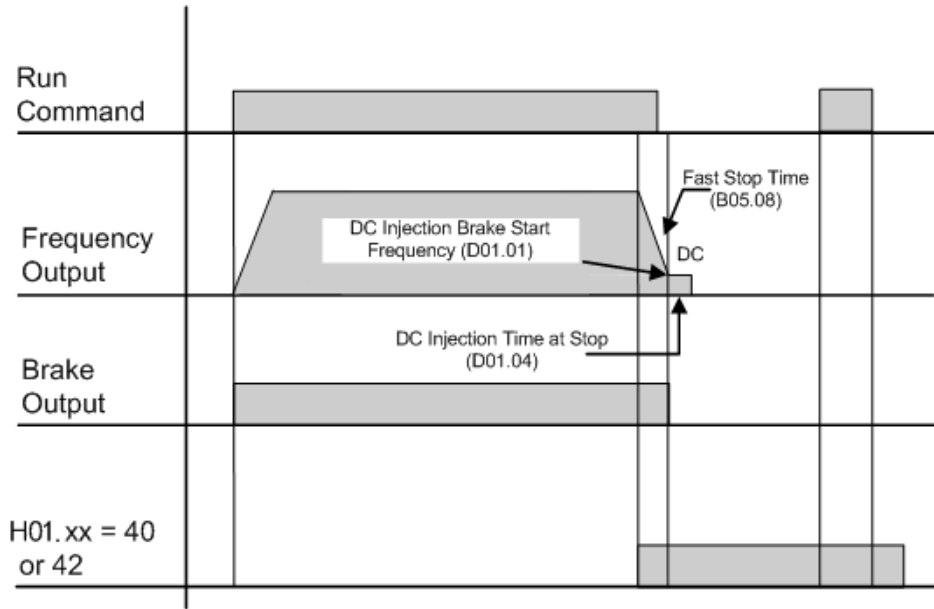

Figure 5-11: H01.XX = 40 or 42 (Fast Stop) without DC Injection

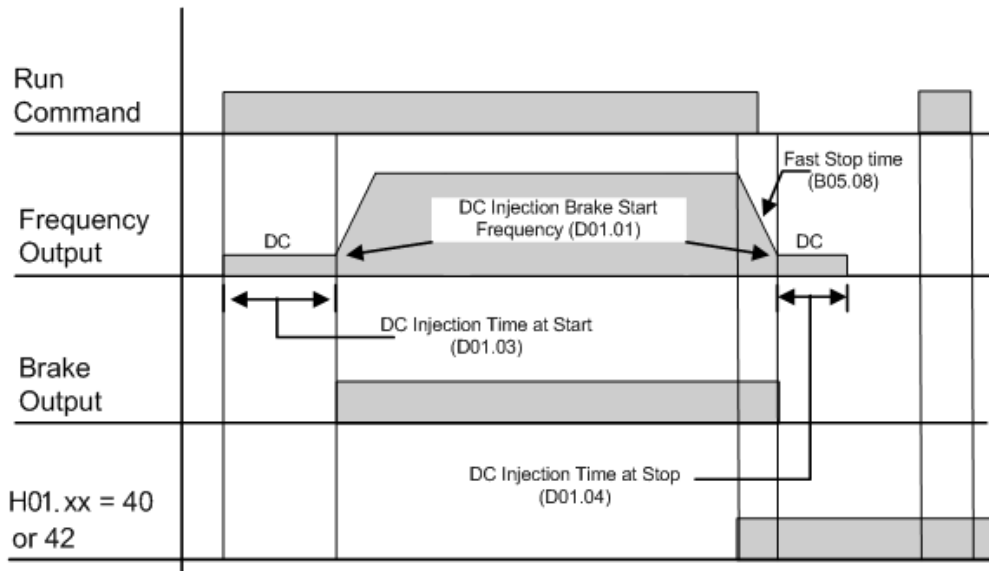

Figure 5-12: H01.XX = 40 or 42 (Fast Stop) with DC Injection

### Motor Rotation Change

This parameter allows you to change the motor direction without changing the motor leads.

Parameter Code	Name	Function	Range	Initial Value	Access Level
B03.04	Reverse Oper	Reverse motor direction	00–01	00	Adv
	00	Normal Rotation			
	01	Exchange Phases			



## LOC/REM Run Select

If the run reference/speed reference are switched between serial mode and drive terminal mode, B03.07 determines action after the switch.

Parameter Code	Name	Function	Range	Initial Value	Access Level
B03.07	LOC/REM Run Sel	Determines action after switching Run/Speed reference source.	00–01	00	Adv
	00 <i>Cycle Extrn Run</i>	If the run command is present at the time when Run/Speed reference source is switched, it requires the run command to be removed and then reapplied from the new source to resume the normal operation.			
	01 <i>Accep Extrn Run</i>	If the run command is present at the time when the Run/Speed reference source is switched, it does not require the run command from the new source to be removed. The normal operation will continue.			
B03.10	Allow Run at Power UP		00–01	00	Adv
	00 <i>Disabled</i>				
	01 <i>Enabled</i>				

Parameter Code	Name	Function	Range	Initial Value	Access Level
B03.15	Reference Source 2 Selection	Source from where the frequency reference is generated.	00–04	01	Adv
	00 <i>Digital Operator</i>	Digital operator (Keypad).			
	01 <i>Terminal</i>	Control circuit terminal			
	02 <i>Communication</i>	Memobus Serial Communication			
	03 <i>Not Used</i>	Not Used			
	04 <i>Pulse Input</i>	Pulse Input (H06.01)			
B03.16	Run Source 2 Selection	Selects run command input source when H01.xx = 1F.	00–03	01	Adv
	00 <i>Digital Operator</i>	Digital operator			
	01 <i>Terminals</i>	Control circuit terminal.			
	02 <i>Memobus Communication</i>	Memobus			
	03 <i>Not Used</i>	Not Used			

## Acceleration/Deceleration

Acceleration time sets the time necessary for the output frequency to accelerate from 0Hz to maximum output frequency (E01.04). Deceleration time sets the time necessary for the output frequency to decelerate from the maximum output frequency (E01.04) to 0Hz.

Parameter Code	Name	Function	Range	Initial Value	Access Level
B05.01	Accel Time 1	Sets acceleration time.	0.0–25.5 sec	5.0*	Basic/Adv
B05.02	Decel Time 1	Sets deceleration time.	0.0–25.5 sec	3.0*	Basic/Adv
B05.03	Accel Time 2	Sets alternate accel time. Enabled by multi-function input=1A.	0.0–6000.0 sec	2.0	Basic/Adv
B05.04	Decel Time 2	Sets alternate decel time. Enabled by multi-function input=1A.	0.0–6000.0 sec	2.0	Basic/Adv
B05.05	Accel Time N Change	Sets acceleration time at Speed Switch frequency.	0.0–25.5 sec	2.0	Adv
B05.06	Decel Time N Change	Sets deceleration time at Speed Switch frequency.	0.0–25.5 sec	2.0	Adv
B05.08	Fault Stop Time	Sets deceleration time for complete stop at external fault. See External Response Selection page 5-50.	0.0–25.5 sec	1.0	Adv
B05.09	Accel/Decel Units	Determines acceleration/deceleration switching level  <i>00 0.01 sec for 0.00-2.55 sec</i> <i>01 0.1 sec for 0.0-25.5 sec</i>	00, 01	01	Adv
		<i>NOTE: Setting will not change if any accel/decel time is &gt; 2.55 sec.</i>			
B05.10	Accel/Decel Switch Frequency	Determines acceleration/deceleration switching level	0.0–150.0 Hz	120	Adv
B05.11	Switch Frequency	Determines when Acceleration Time and Deceleration Time at Speed Switch Hz is enabled  <i>00 lower SW freq</i> <i>01 upper SW freq</i>	0.0–6000.0	01	Adv
		B05.05/06 is enabled, N-out ≤ B5.10			
		B05.06 is enabled, N-out ≥ B5.10			
B05.12	Accel Time 3	Acceleration time when H01.01 to H01.07 = 1B	0.0–6000.0	3.0	Adv
B05.13	Decel Time 3	Deceleration time when H01.01 to H01.07 = 1B	0.0–6000.0	3.0	Adv
B05.14	Accel Time 4	Acceleration time when H01.01 to H01.07 = 1C	0.0–6000.0	3.0	Adv
B05.15	Decel Time 4	Deceleration time when H01.01 to H01.07 = 1C	0.0–6000.0	3.0	Adv

\* Initial value is determined by X-Press Programming (Table 4.1 to 4.2).

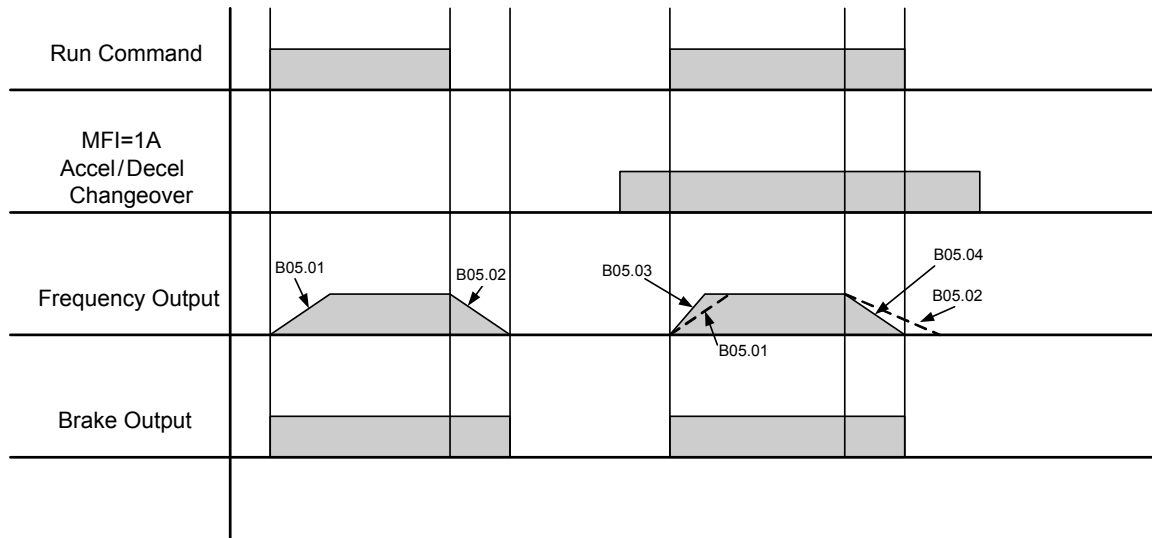

NOTE: Assume the constant B03.03 is set to "00" (Decel to Stop).

Figure 5-13: Normal Accel/Decel Time and Multiple Accel/Decel Changeover

## Jump Frequencies

This function allows the "jumping" of critical frequencies so that the motor can operate without resonant vibrations caused by some machine systems. This function is also used for deadband control. Setting the value to 0.0 Hz disables this function.

Parameter Code	Name	Function	Range	Initial Value	Access Level
B08.01	Jump Frequency 1	First of three jump frequencies.	0.0–150.0 Hz	0.0	Adv
B08.02	Jump Frequency 2	Second of three jump frequencies.	0.0–150.0 Hz	0.0	Adv
B08.03	Jump Frequency 3	Third of three jump frequencies.	0.0–150.0 Hz	0.0	Adv
B08.04	Jump Bandwidth	Jump frequency reference bandwidth.	0.0–20.0 Hz	1.0	Adv

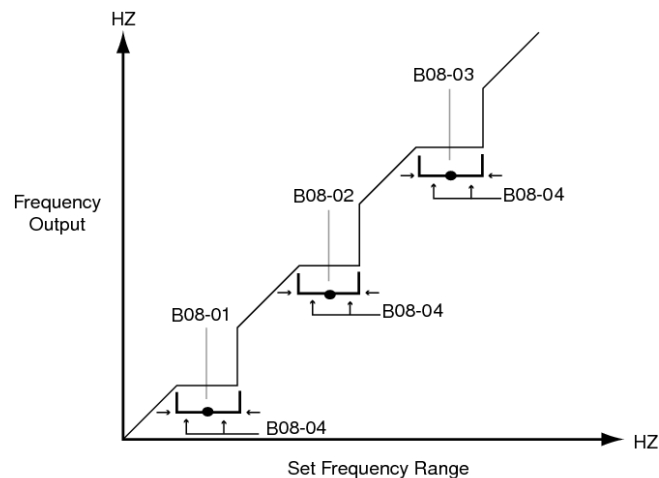

# Special Functions

The special function parameters are special crane and hoist specific functions used to control how the system will operate. These include Quick Stop™ and Reverse Plug Simulation™. Listed below are the special function parameters covered in this section.

- C1 Quick Stop
- C1 Reverse Plug Simulation
- C2 Micro Positioning
- C3 End of Travel Limit
- C3 Phantom Stop
- C3 Klixon
- C5 Load Check II
- C6 Swift-Lift
- C7 Torque Limit
- C8 Brake Answer Back
- C12 Brake Delay Timers
- C12 On/Off Delay Timers
- C12 Maintenance Timer
- C13 Inching Control

Special Function	A01.01 = 02 (Advanced)					
	Traverse (00)		Hoist (01)		Braketronic (04)	
	V/f (00)	OLV (02)	V/f (00)	OLV (02)	V/f (00)	OLV (02)
C1: Quick Stop	○	○	○	○	○	○
C1: Reverse Plug Simulation	○	○	○	○	○	○
C2: Micro Positioning	○	○	○	○	○	○
C3: End of Travel Limits	○	○	○	○	○	○
C3: Phantom Stop	○	○	○	○	○	○
C3: Klixon	○	○	○	○	○	○
C5: Load Check II	×	×	○	○	×	×
C6: Swift-Lift	×	×	○	○	×	×
C7: Torque Limit	×	○	×	○	×	○
C8: Brake Answerback	○	○	○	○	○	○
C12: Brake Delay Timers	○	○	×	×	×	×
C12: On/Off Delay Timers	○	○	○	○	○	○
C12: Maintenance Timer	○	○	○	○	○	○
C13: Inching Control	○	○	○	○	×	×
D8: Dwell	×	×	×	×	○	○

○: Available for the Motion selected

×: Not available for the Motion selected

## Quick Stop

The **Quick Stop Function** provides an automatic Alternate Deceleration at Stop Command.

*NOTE: The Quick Stop Deceleration time differs from the normal deceleration time and is applied only when the RUN command is removed.*

Parameter Code	Name	Function	Range	Initial Value	Access Level
C01.01	Quick Stop 0/1	Determines whether Quick Stop is enabled <i>00 Disabled</i> <i>01 Enabled</i>	00–01	00*	Basic/Adv
C01.02	Quick Stop Time	Deceleration time during Quick Stop function.	0.0–25.5 sec	1.0	Basic/Adv

\* Initial value is determined by X-Press Programming (Table 4.1 to 4.2).

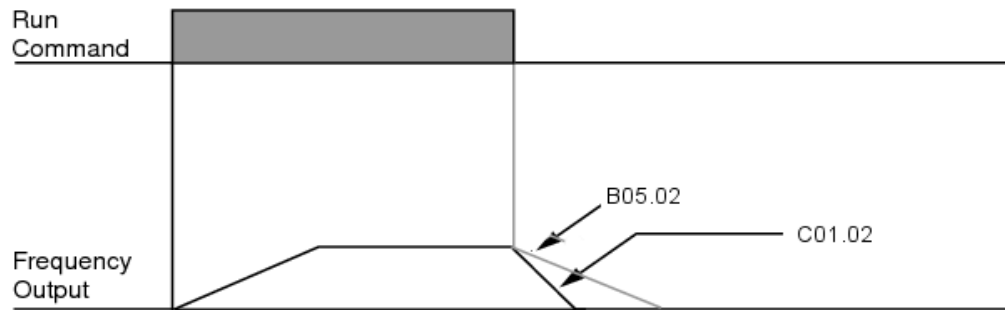
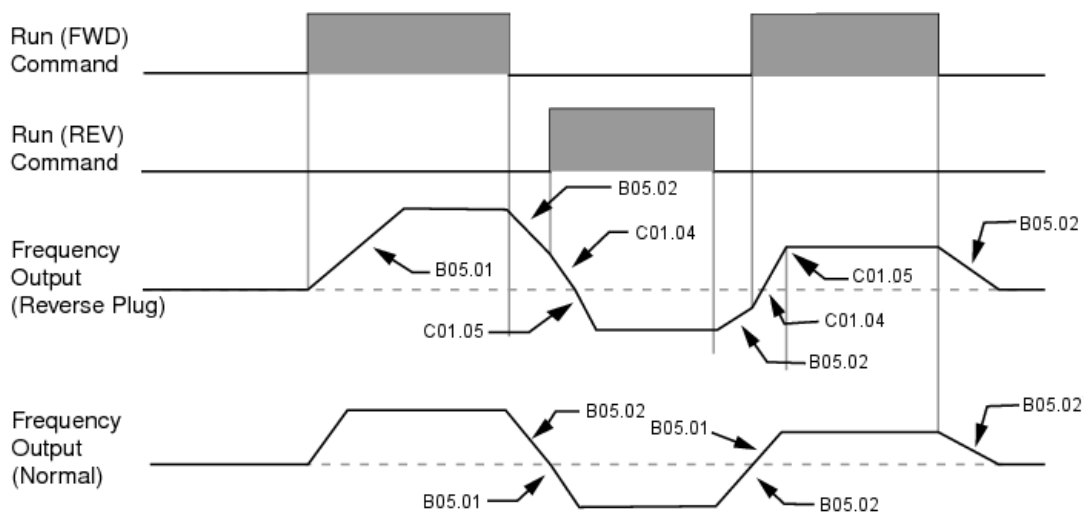

**Figure 5-14: Quick Stop**

## Reverse Plug Simulation™

The **Reverse Plug Simulation** provides an automatic alternate deceleration time/acceleration time at a change direction command before the brake sets. The deceleration time and the acceleration time are set independently of the normal acceleration and deceleration times.

Parameter Code	Display	Function	Range	Initial Value	Access Level
C01.03	Reverse Plug	Determines whether Reverse Plug Simulation is enabled. <i>00 Disabled</i> <i>01 Enabled</i>	00–01	00	Basic/Adv
C01.04	Reverse Plug Decel Time	Deceleration time during Reverse Plug Simulation.	0.0–25.5 sec	2.0	Basic/Adv
C01.05	Reverse Plug Accel Time	Acceleration time during Reverse Plug Simulation	0.0–25.5 sec	2.0	Basic/Adv

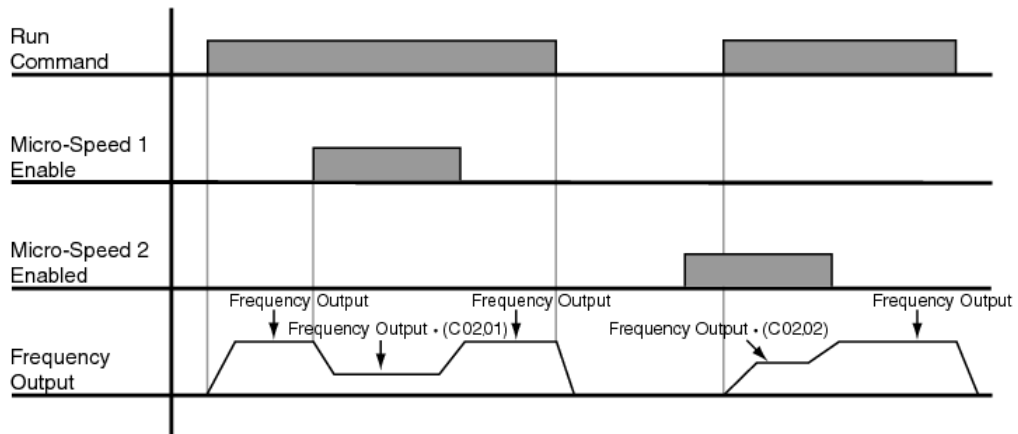

**Figure 5-15: Reverse Plug Simulation**

# Micro-Positioning Control™

Micro-Positioning Control function can provide a reduced speed range operation for precise positioning. Enabled by a Multi-Function Input, it multiplies the normal speed reference by the Micro-Speed Gain. Two Micro-Speed Gains are available: Gain 1 (C02.01) and Gain 2 (C02.02). They can be adjusted and enabled independently.

Parameter Code	Name	Function	Range	Initial Value	Access Level
C02.01	MicroSpd Gain 1	The multiplier of the Analog or Digital Speed Reference to achieve slow-speed operation. Multi function Input = 0E	0.00–2.55	1.00	Adv
C02.02	MicroSpd Gain 2	An alternate multiplier of the Analog or Digital Speed Reference to achieve slow-speed operation. Multi function Input = 10	0.00–2.55	1.00	Adv



**Figure 5-16: Micro-Positioning Control**

**NOTE:** If both Micro-Speed 1 and Micro-Speed 2 are enabled, Micro-Speed 1 always takes higher priority over Micro-Speed 2.

## Travel Limits

This function can automatically slow and stop a crane or hoist when it reaches the end of the travel limits. Two types of limit inputs (slow and stop) are available in both travel directions. Inputs can be programmed through H01.01–H01.07.

When the crane reaches either the Upper Limit 1 (UL1) or Lower Limit 1 (LL1), the drive will decelerate to the Upper and Lower Limit speeds C03.01 and C03.04 respectively. When the crane reaches either the Upper Limit 2 (UL2) or Lower Limit 2 (LL2), the drive will come to a stop based on the Limit Stopping Method (C03.07). If C03.07 is set to 00, then the deceleration time will use Upper Limit 2 Stop Time (C03.03) or Lower Limit 2 Stop Time (C03.06).

Parameter					Access
Code	Name	Function	Range	Initial Value	Level
C03.01	Upper Limit 1 Speed	Speed at Upper Limit input.	0.00–150.00 Hz	6.00	Basic/Adv
C03.02	Upper Limit 1 (UL1) Decel Time	Decel time to Upper Limit Speed.	0.0–25.5 sec	1.0	Basic/Adv
C03.03	Upper Limit 2 (UL2) Stop Time	Decel time to STOP when Upper Limit is input.	0.0–25.5 sec	1.0	Basic/Adv
C03.04	Lower Limit 1 Speed	Speed at Lower Limit input.	0.00–150.00 Hz	6.00	Basic/Adv
C03.05	Lower Limit 1 (LL1) Decel Time	Decel time to Lower Limit Speed	0.0–25.5 sec	1.0	Basic/Adv
C03.06	Lower Limit 2 (LL2) Stop Time	Decel time to STOP when Lower Limit is input.	0.0–25.5 sec	1.0	Basic/Adv
C03.07	Limit Action @ LL2/UL2	Determine the stop method at Upper Limit 2 and Lower Limit 2 Input. 00 Decel to Stop 01 Coast to Stop 02 Use B03.03 Method	00–02	02*	Basic/Adv
C03.08	Limit Action @ UL3	Weight Limit Stop Method and action when Multi-Function Input H01.01 ~ H01.07 = 12 or 62 00 Decel/Alarm (no further raise allowed) 01 Coast/Alarm (no further raise allowed) 02 Use B03.03/Alarm (no further raise allowed) 03 Decel/Fault 04 Coast/Fault 05 Use B03.03/Fault Note: For setting 00, 02, 03, 05, deceleration is by B05.08.	00–05	04	Adv

\* Initial value is determined by X-Press Programming



## Phantom Stop

The Phantom Stop feature is designed to stop the drive operation using the stopping method selected in C03.09 when a Phantom Fault input (H01.01–H01.07 = 5F or 63) is active. The drive will indicate a Phantom Fault has occurred by blinking the LED on the RUN key in sequence of two short bursts. The drive will resume normal operation when a Phantom Fault is removed.

Parameter					Access
Code	Name	Function	Range	Initial Value	Level
C03.09	Phantom Stop Selection	Stopping Method when Multi-Function Input H01.01–H01.07 = 5F or 63 (Phantom Fault) 00 Decel to Stop 01 Coast to Stop 02 Use B03.03 Method	00–02	01	Adv

## Klixon Action

The Klixon Multi-Function input is intended for motors that have a Motor Thermal Overload Switch called a Klixon. The Klixon is usually embedded in the motor windings, and changes state when the motor reaches a certain temperature. When a multi-function input (H01.01~H01.07 = 56 or 57) is active, the drive will use the stopping method programmed in C03.11 and display the oL8 Klixon alarm. The drive will resume normal operation when the motor cools down and the input changes state for normal operation.

Parameter					Access
Code	Name	Function	Range	Initial Value	Level
C03.11	Klixon Action	Stopping Method when Multi-Function input H01.01–H01.07 = 56 or 57 00 Use B03.03 Method 01 Allow Lower Only	00–01	00	Adv

## Load Check II™

The Load Check II function is a load-limiting feature which ensures the programmed load limit of the hoist is not exceeded. It prevents the lifting (and potential stall) of a load that is overweight. When the IMPULSE•G+ Mini detects an overload condition it prevents any further lifting. The load may then be lowered at the speed that is specified by the Load Check Lowering Speed (C05.08).

### V/f Operation (A01.02 = 00)

When using Load Check II in V/f control mode (during lifting) the IMPULSE•G+ Mini will compare the motor current readings (U01.03) to values stored during the Load Check set up process. If they exceed the values for the active Load Check Zone, the IMPULSE•G+ Mini will stop based on the LC Alarm Action (C05.02) and display a Load Check alarm (LC).

### OLV Operation (A01.02 = 02)

When using Load Check II in Open Loop Vector control mode (during lifting) the IMPULSE•G+ Mini will compare the motor torque readings (U01.09) to values stored during the Load Check set up process. If they exceed the values for the active Load Check Zone, the IMPULSE•G+ Mini will stop based on the LC Alarm Action (C05.02) and display a Load Check alarm (LC).

*NOTE: Precautions should be taken when using load check where two or more hoists are used to lift a single load.*

*Example: Use a normally closed relay from the load check output to break the raise (FWD Run) command to the other hoist(s). This will ensure that all hoists stop lifting if one hoist is overloaded.*

### Load Check II Set Up (C05.01 = 09)

The Load Check set up procedure will quickly measure and calculate the current or torque required at each of the Load Check Zones. These values will automatically be stored in parameters C05.09 through C05.24 during the Load Check set up process.

To following are the steps required to perform the Load Check set up process.

1. Auto-tune the motor.
  - OLV operation – Rotational Auto-tune (stationary is acceptable, though not ideal).
  - V/f operation – Stationary Auto-tune.
2. With Load Check disabled, lift the rated load a foot or two off the ground.
3. Set C5.01 equal to 09.
4. Press and hold the Hoist (up) command button on the pendant or radio for full speed operation (60 Hz).

*NOTE: The Load Check set up process can be temporarily paused by lowering the load block to the ground (suspended), then pressing and holding the Hoist (up) command button at full speed until the Load Check set up process is complete.*

5. When the Load Check set up process finishes its calculations, the drive will decelerate the load to indicate that the set up calibration is complete.
6. Press the Lower (down) command to complete the Load Check set up process.
7. Lift the rated load numerous times to ensure there are no unwanted LC faults. If an LC alarm is detected, increase the LC Margins (C5.05 and C5.07).

Parameter Code	Name	Function	Range	Initial Value	Access Level
C05.01	Load Check (LC)	Used to set up and enable the Load Check function.  <i>00 Disable</i> <i>01 Enable Load Check</i> <i>03 Enable Load Check Continuous</i> <i>09 Load Check Set Up</i>	00, 01, 03, 09	00	Adv
C05.02	LC Alarm Action	Sets the action at a Load Check alarm or fault (Fault reset is required via keypad or MFDI to raise the load).  <i>00 Alarm Only (Continue operation)</i> <i>01 Decel to Stop (Allows lower only)</i> <i>02 Coast to Stop (Allows lower only)</i> <i>03 Fault Stop (No operation)</i> <i>04 Use B3-03 Method (allows lower only)</i>	00–04	04	Adv
C05.03	LC Setting Time	Sets the time to hold the output frequency allowing the output current/torque to stabilize.	0.00–2.55 sec	0.15	Adv
C05.04	LC Testing Time	Sets the time (after the LC Setting Time) for comparing output current/torque to values for a particular LC Zone being tested.	0.00–2.55 sec	0.25	Adv
C05.05	LC Acceleration Margin	Sets the margin for Load Check detection during acceleration. A setting of 00 is the most sensitive.	00–50	5	Adv
C05.07	LC Margin	Sets the margin for Load Check detection at speed agree. A setting of 00 is the most sensitive.	00–20	5	Adv
C05.08	LC Lowering Speed	Sets the maximum lowering speed after an LC alarm.	0.1–30.0 Hz	6.0	Adv
C05.09	LC Zone 01	Current/Torque values detected during LC set up for Zone 01	000–160%	000	Adv
C05.10	LC Zone 02	Current/Torque values detected during LC set up for Zone 02	000–160%	000	Adv
C05.11	LC Zone 03	Current/Torque values detected during LC set up for Zone 03	000–160%	000	Adv
C05.12	LC Zone 04	Current/Torque values detected during LC set up for Zone 04	000–160%	000	Adv
C05.13	LC Zone 05	Current/Torque values detected during LC set up for Zone 05	000–160%	000	Adv
C05.14	LC Zone 06	Current/Torque values detected during LC set up for Zone 06	000–160%	000	Adv
C05.15	LC Zone 07	Current/Torque values detected during LC set up for Zone 07	000–160%	000	Adv
C05.16	LC Zone 08	Current/Torque values detected during LC set up for Zone 08	000–160%	000	Adv
C05.17	LC Zone 09	Current/Torque values detected during LC set up for Zone 09	000–160%	000	Adv
C05.18	LC Zone 10	Current/Torque values detected during LC set up for Zone 10	000–160%	000	Adv
C05.19	LC Zone 11	Current/Torque values detected during LC set up for Zone 11	000–160%	000	Adv
C05.20	LC Zone 12	Current/Torque values detected during LC set up for Zone 12	000–160%	000	Adv

Parameter Code	Name	Function	Range	Initial Value	Access Level
C05.21	LC Zone 13	Current/Torque values detected during LC set up for Zone 13	000–160%	000	Adv
C05.22	LC Zone 14	Current/Torque value detected during LC set up for Zone 14	000–160%	000	Adv
C05.23	LC Zone 15	Current/Torque value detected during LC set up for Zone 15	000–160%	000	Adv
C05.24	LC Zone 16	Current/Torque value detected during LC set up for Zone 16	000–160%	000	Adv
C05.25	LC Integral Time	Integral time used to smooth transitions	0.00–2.55 sec	0.05	Adv
C05.26	LC Delay Time	Load Check delay time for transitions	0.00–2.55 sec	0.25	Adv
C05.27	LC Rev Dir Delay	Minimum delay between Reverse to Forward transition after Reverse frequency exceeds C05.28	0.00–2.55 sec	0.00	Adv
C05.28	LC Rev Dir Freq	Minimum frequency that will trigger the C05.27 delay	0.0–60.0 Hz	30.0	Adv

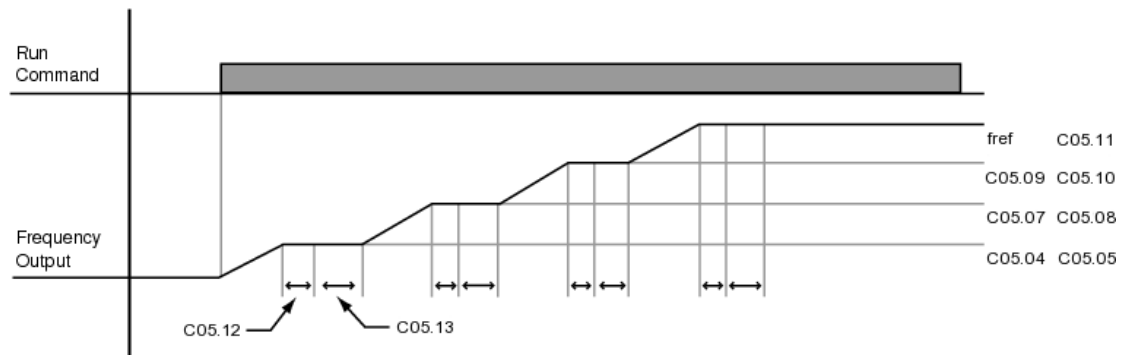

Figure 5-17: Load Check

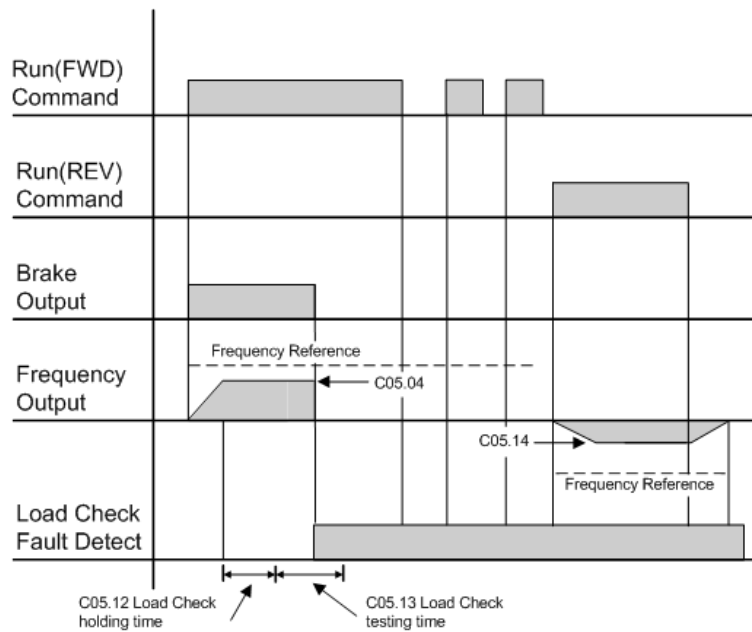

Figure 5-18: Example of Operation C05.02 = 01 or 04

## Swift-Lift™

Swift-Lift provides additional productivity by allowing a hoist to quickly move into position by increasing speeds under light or no load conditions. Swift-Lift will enable the motor to over-speed by calculating the maximum safe speed and automatically accelerating to this speed. However, the maximum speed cannot exceed the lesser of the Swift-Lift Forward Speed (C06.02) or Swift-Lift Reverse Speed (C06.03) and the Max Output Frequency (E01.04).

*NOTE: Swift-Lift is disabled when in traverse applications.  
The maximum frequency (E01.04) ≥ C06.02 and C06.03.*

There are two methods that may be utilized to enable Swift-Lift:

- 1) Automatic: Swift-Lift can be enabled to automatically occur whenever the load is less than the maximum percentage of motor current (C06.04 or C06.05) and the output frequency is greater than the Swift Lift Enabling Speed (C06.06).
- 2) Manual: Swift-Lift may be enabled manually through the Multi-Functional Digital Inputs by setting H01.01 ~ H01.07 = 13.



### WARNING

*Motors and drive machinery must be capable of operating above motor base speed. Consult the motor/gearbox/hoist manufacturer before enabling Swift-Lift function. Failure to observe this warning may result in damage to equipment and possible injury or death to personnel.*

Parameter Code	Name	Function	Range	Initial Value	Access Level
C06.01	Swift-Lift	Determines whether Swift-Lift is enabled.  00 Disabled 01 Enabled Automatic 02 Enabled by MFI = 13	00–02	00	Basic/Adv
C06.02	Swift-Lift Forward Speed	Maximum Output Frequency during Swift-Lift—FORWARD.	0.0–150.0 Hz	60.0	Basic/Adv
C06.03	Swift-Lift Reverse Speed	Maximum Output Frequency during Swift-Lift—REVERSE.	0.0–150.0 Hz	60.0	Basic/Adv
C06.04	Swift-Lift Forward Torque	Maximum output current below which Swift-Lift—FORWARD is enabled.	000–100%	50	Basic/Adv
C06.05	Swift-Lift Reverse Torque	Maximum output current below which Swift-Lift REVERSE is enabled.	000–100%	30	Basic/Adv
C06.06	Swift-Lift Enabling Spd	Threshold frequency at which Swift-Lift is enabled.	0.0–150.0 Hz	59.0	Basic/Adv
C06.07	Swift-Lift Delay Time	Delay time at enabling speed prior to torque-compare function.	0.0–25.5 sec	2.0	Basic/Adv
C06.08*	Swift Lift Acceleration Gain	Speed feedback acceleration multiplier	0.1–9.9	1.0	Adv

\* Only available when A01.02 = 00 (V/f)

## Configuring the Swift-Lift Function:

### Using Multi-Step 2, 3, 5 (A01.04 = 00, 01, or 02):

If the system is using **Multi-Step** as the **Speed Control Method**, use the following instructions to set up Swift-Lift.

1. Set **V/f Selection (E01.03) = 0F** to allow for a custom V/f pattern.

*NOTE: Choosing a Custom V/f pattern will require setting of E01.01 ~ E01.13 parameters to the current V/f selection. For additional V/f selections, see tables 5-5 and 5-6.*

2. Ensure that the **Maximum Frequency (E01.04)** is increased from 60 Hz and will be equal to or slightly greater than the maximum Swift-Lift Forward or Reverse speeds you want to run at.

Maximum frequency (E01.04)  $\geq$  C06.02 and C06.03.

3. Set C06.01 = 01 or 02 to enable the **Swift-Lift Function**.
  - a. 01 = Enable Automatic
  - b. 02 = Enable by Multi-Function Input (MFI).
4. Set C06.02 and C06.03 to determine **Swift-Lift** maximum FWD/REV output frequency.
5. Set C06.04 and C06.05 to determine **Swift-Lift** maximum enable output current.
6. Set the **Swift-Lift Enabling Speed (C06.06)** one or two hertz below the maximum normal running speed reference.
  - a. For example: If the maximum normal running speed is at 60 Hz, set C06.06 to 58 or 59 Hz as the **Swift-Lift Enabling Speed**.

### Using Infinitely Variable 2, 3 Step (A01.04 = 03 or 04):

If the system is using **2-Step** or **3-Step Infinitely Variable** as the **Speed Control Method**, use the following formula to adjust the constant **B02.01 (Reference Upper Limit)**:

$$B02.01 = (60 \text{ Hz} \times 100) / E01.04$$

1. Set **V/f Selection (E01.03) = 0F** to allow for setting a custom V/f pattern.

*NOTE: Choosing a Custom V/f pattern will require setting of E01.01 ~ E01.13 parameters to the current V/f selection. For additional V/f selections, see tables 5-5 and 5-6.*

2. Ensure that the **Maximum Frequency (E01.04)** is increased from 60 Hz and will be equal to or slightly greater than the maximum Swift-Lift Forward or Reverse speeds you want to run at.
  - a. Maximum frequency (E01.04)  $\geq$  C06.02 and C06.03.

3. Set the Frequency Upper Limit (B02.01). This is done so that the *maximum normal running speed* will be 60 Hz with the new E01.04 setting.

- a. For example, if E01.04 is set to 75.0 Hz, then B02.01 = 80%

$$B02.01 = (60.0 \text{ Hz} \times 100\%) / (75.0 \text{ Hz}) = 80\%$$

4. Set C06.01 = 01 or 02 to enable the **Swift-Lift Function**.
  - a. 01 = Enable Automatic.
  - b. 02 = Enable by Multi-Function Input (MFI).
5. Set C06.02 and C06.03 to determine **Swift-Lift** maximum FWD/REV output frequency.
6. Set C06.04 and C06.05 to determine **Swift-Lift** maximum enable output current.

7. Set the **Swift-Lift Enabling Speed (C06.06)** one or two hertz below the *maximum normal running speed* reference (see step 3).
  - a. For example: if the *maximum normal running speed* is at 60 Hz, set C06.06 to 58 or 59 Hz as the **Swift-Lift Enabling Speed**.

**Using Uni-Polar Analog (A01.04 = 05):**

If the system is using **Uni-Polar Analog** as the **Speed Control Method**, use the following formula to adjust the constants **H03.03 (Gain Multiplier for Terminal A1 analog input signal)** or **H03.11 (Gain Multiplier for Terminal A2 analog input signal)**:

$$\text{Gain Terminal A1: } H03.03 = (60 \text{ Hz} \times 100) / E01.04$$

or

$$\text{Gain Terminal A2: } H03.11 = (60 \text{ Hz} \times 100) / E01.04$$

1. Set **V/f Selection (E01.03) = 0F** to allow for setting a custom V/f pattern.
2. Ensure that the **Maximum Frequency (E01.04)** is increased from 60 Hz and will be equal to or slightly greater than the maximum Swift-Lift Forward or Reverse speeds you want to run at.
  - a. Maximum frequency (E01.04)  $\geq$  C06.02 and C06.03.
3. Set the terminal gain multiplier for H03.03 or H03.11. This is done so that the *maximum normal running speed* will be 60 Hz with the new E01.04 setting. Use one of the above equations to determine the correct multiplier.
  - a. For example, to set the gain for Terminal A1 if E01.04 is set to 80.0 Hz, then  $H03.03 = 75\%$   

$$H03.03 = (60.0 \text{ Hz} \times 100\%) / (80.0 \text{ Hz}) = 75\%$$
4. Set C06.01 = 01 or 02 to enable the **Swift-Lift Function**:
  - a. 01 = Enable Automatic.
  - b. 02 = Enable by Multi-Function Input (MFI).
5. Set C06.02 and C06.03 to determine **Swift-Lift** maximum FWD/REV output frequency.
6. Set C06.04 and C06.05 to determine **Swift-Lift** maximum enable output current.
7. Set the **Swift-Lift Enabling Speed (C06.06)** one or two hertz below the *maximum normal running speed* reference (see step 3).
  - a. For example: if the *maximum normal running speed* is at 60 Hz, set C06.06 to 58 or 59 Hz as the **Swift-Lift Enabling Speed**.

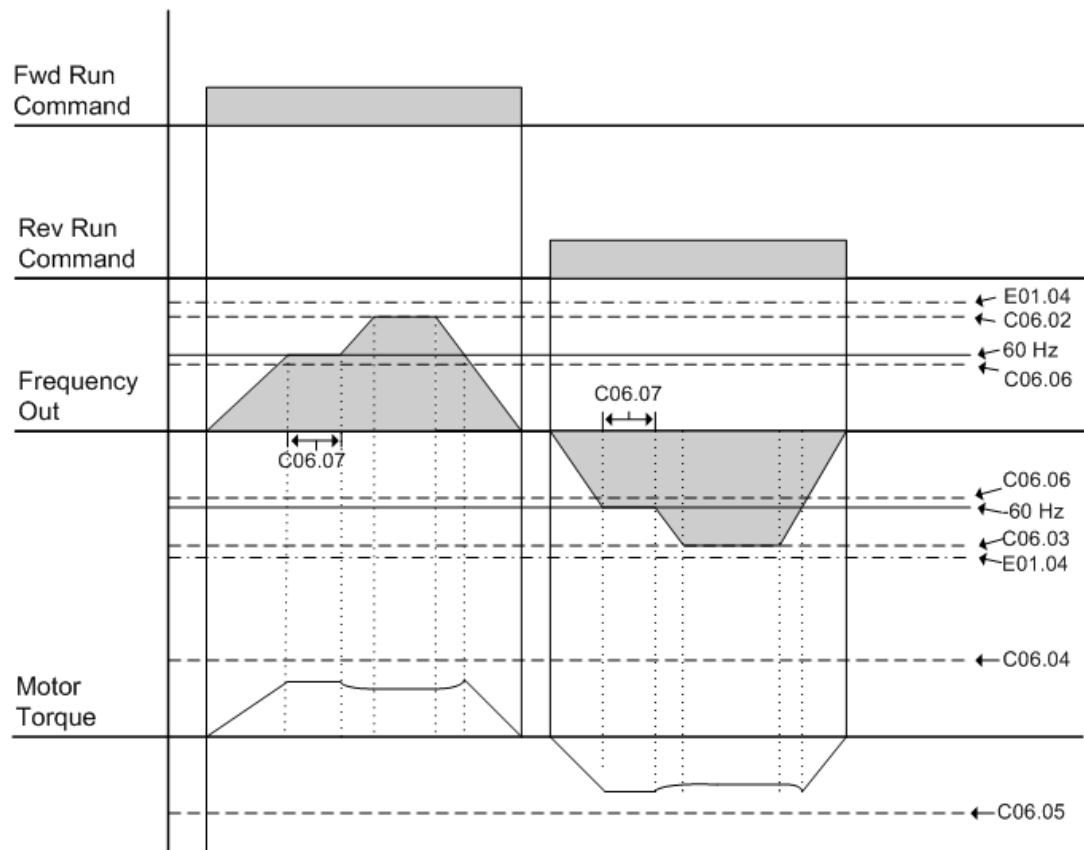

**Figure 5-19: Swift Lift Timing Diagram**



## Torque Limit (Open Loop Vector Only)

IMPULSE•G+ Mini dynamically controls the torque output of the motor at all times when the control method is set to Open Loop Vector (A01.02 = 02). The Torque Limit Function limits the amount of motor torque on all four quadrants of vector control operation:

- *Forward Motoring*
- *Reverse Motoring*
- *Forward Regenerating*
- *Reverse Regenerating*

When the torque limits are reached during operation, the programmed acceleration and deceleration times become second priority.

Parameter Code	Name	Function	Range	Initial Value	Access Level
C07.01	Forward Torque Limit	FORWARD torque limit	000–300%	150	Adv
C07.02	Reverse Torque Limit	REVERSE torque limit	000–300%	150	Adv
C07.03	Forward Regen Torque Limit	Regenerative torque limit at FORWARD	000–300%	180	Adv
C07.04	Reverse Regen Torque Limit	Regenerative torque limit at REVERSE	000–300%	180	Adv
C07.05	Torque Limit Gain	Used when H1-01~H1-07 = 14 and MFI is on	0.00–2.55	1.25	Adv
C07.06	Torque Limit Time Constant	Torque Limit Integral Time Constant	5–10000ms	00200	Adv
C07.07	Torque Limit Select	Torque Limit Select <i>00 P Control</i> <i>01 PI Control</i>	00–01	00	Adv

## Brake Answerback

The following timers are used when a multi-function input (H01.01–H01.07) is set for 58, brake answerback.

<b>Parameter Code</b>	<b>Name</b>	<b>Function</b>	<b>Range</b>	<b>Initial Value</b>	<b>Access Level</b>
C08.04	Rollback Timer	Sets the amount of time for the brake to release and for brake feedback to be received into the Brake Answer Back Multi-Function input at start before posting BE4 alarm. It is also the time period during which the amount of roll back is checked.	0.00–2.55 sec	0.30	Adv
C08.11	Brake Set Delay	Sets the amount of time for the brake to set and for brake feedback to be removed from the Brake Answer Back Multi-Function input at stop before posting a BE5 Alarm.	0.0–25.5 sec	0.7	Adv
C08.17	Up Speed Limit	Maximum speed in Forward (Up) direction by BE6.	0.00–150.00	6.00	Adv

## Brake Delay Timers

This function is used in trolley or bridge applications. It can reduce the mechanical brake wear when the operator tries to position a load. This function is available only in traverse mode and the constant B03.03 must be set to 04 (Decel With Timer).

Parameter Code	Name	Function	Range	Initial Value	Access Level
C12.01	Brake Jog Delay	Brake set delay time at Jog Control input.	0.0–100.0 sec	0.0 sec	Adv
C12.02	Brake Run Delay	Brake set delay time at RUN input.	0.0–100.0 sec	0.0 sec	Adv

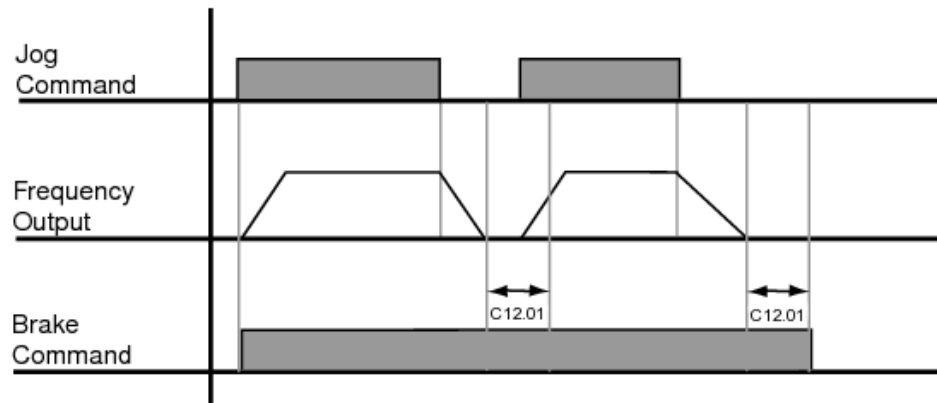

**Figure 5-20: Brake Delay Timers**

**NOTE:** The Jog control input is a multi-function input. It is enabled by programming data 15 or 16 in H01.01 ~ H01.07.

## ON/OFF Delay Timer Function

- The timer function is enabled when the timer function input (H01.01~H1.07 = 043) and the timer function output (H02.01~H02.03 = 012) are set for the multi-function input and multi-function output respectively.
- These inputs and output serve as general purpose I/O. Chattering of sensors, switches, contactors, etc., can be prevented by setting a delay time.
- When the timer function input **ON** time is longer than the value set for **C12.03** (Timer function ON-Delay Time), the timer function output turns **ON**.
- When the timer function input **OFF** time is longer than the value set for **C12.04** (Timer function OFF-Delay Time), the timer function output turns **OFF**.

Parameter Code	Name	Setting Range	Factory Default Setting	Access Level
C12.03	Delay-on timer	0.0–3000.0	0.0	Adv.
C12.04	Delay-off timer	0.0–3000.0	0.0	Adv.

## Maintenance Timer

The maintenance timer feature will set an output after a pre-determined period of time (hours) to alert an operator to perform or take some action, i.e. grease the bearings.

To use this feature, program the number of hours between each maintenance cycle in C12.05. Then program a multi-function input for maintenance timer enable (H01.01–H01.07 = 043). Finally, program a multi-function output for timer output (H02.01~H02.03 = 037). Enable the maintenance timer by closing the multi-function input for maintenance timer enable. U01.52 will display the maintenance timer accumulator. Setting C12.05 = 00000 will disable this function.

When the pre-determined time has been reached (C12.05), the multi-function output will close, the keypad will flash “MNT,” and the drive will slow down to the speed determined by the Maintenance Speed Gain (C12.06).

The maintenance alarm can be set in one of two methods.

**Method 1:** A multi-function input can be programmed for Maintenance Reset (H01.01–H01.07 = 05A). Closing this input will reset the maintenance accumulator (U01.52) and reset the multi-function output.

**Method 2:** Press the Local/Remote (LO/RE) button three consecutive times with no more than 2 seconds between each press until the blinking RESET message is displayed. Press ENTER to reset the maintenance timer. The RESET message will stop blinking when maintenance is reset. The Multi-Function Output will turn off at this time.

Parameter Code	Name	Function	Range	Initial Value	Access Level
C12.05	Maintenance Timer	Maintenance Timer Trip Level	00000–32767	00000	Adv
C12.06	Maintenance Speed Gain	Speed Reference Gain	0.00–1.00	0.5	Adv

## Inching Control

Inching Control Function can be enabled by programming data 17, 18, and 19 respectively to the multi-function input terminals (H01.01–H01.07). The frequency reference used during inching is determined by B01.17 (Jog Reference).



Parameter Code	Name	Function	Range	Initial Value	Access Level
C13.01	Inch Run Time	Inching Control run time.	0.00–2.55 sec	1.00	Adv
C13.02	Repeat Delay Time	Inching Control repeat delay time.	0.00–2.55 sec	1.00	Adv
H01.01 ~ H01.07	Terminal Selection	Multi-Function Input Terminals	00–81	--	Adv

*17 Forward Inch*  
*18 Reverse Inch*  
*19 Inch Repeat*

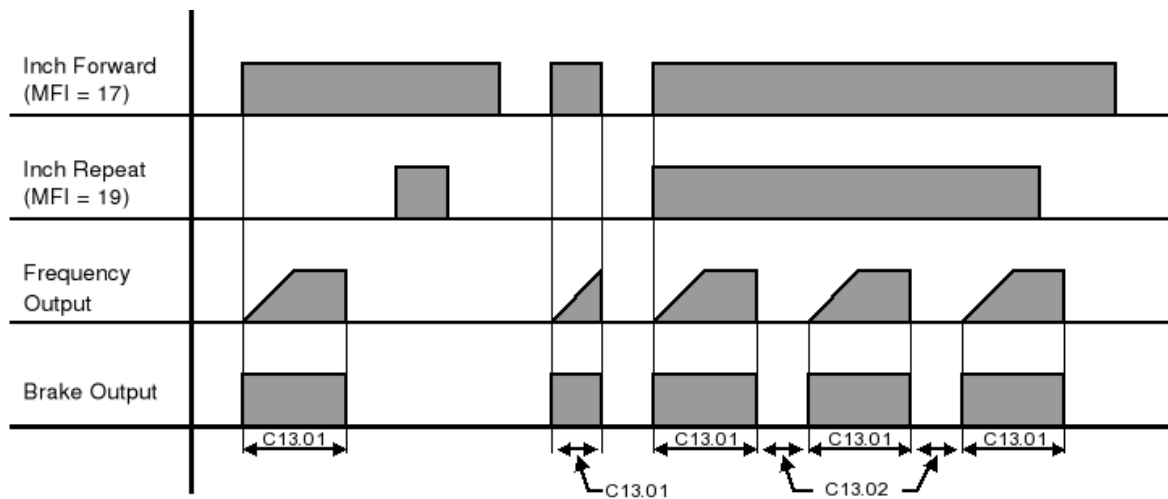

**Figure 5-21: Inching Function and Inching Repeat**

**NOTE:** C13.01 did not expire during the second inch forward command.

# Tuning

These parameters help tune the motor for your application, which include Torque Compensation and S-Curve characteristics for smoother transition during machine acceleration and deceleration. Below are the parameters included in this section.

- D1 DC Injection
- D2 Automatic Slip Compensation
- D3 Torque Compensation
- D8 Dwell Function
- D9 S-Curve Acceleration/Deceleration
- D10 Carrier Frequency
- D11 Hunting Prevention

## DC Injection

DC Injection can be used to stop a motor whose rotational direction is uncertain at start-up.

With Decel to Stop enabled (B03.03 = 00), upon removal of the run command the IMPULSE•G+ Mini drive controls motor deceleration according to the Decel Time setting, until output frequency reaches the DC Injection Braking Start Frequency (D01.01 setting). Then the drive output is turned off and DC injection current is applied to the motor. The effective DC injection time and current should be set to provide adequate stopping without excessive motor heating. The DC injection voltage is determined by the DC injection braking current and motor impedance.

Parameter Code	Name	Function	Range	Initial Value	Access Level
D01.01	DC Injection Start Frequency	DC Injection braking frequency start.	0.0–10.0 Hz	0.5	Basic/Adv
D01.02	DC Injection Current	% of Inverter rated current.	0–75%	50	Basic/Adv
D01.03	DC Injection Time @ Start	DC Injection braking time.	0.00–10.00 sec	0.00	Basic/Adv
D01.04	DC Injection Time @ Stop	DC Injection braking time at stop.	0.00–10.00 sec	0.05	Basic/Adv

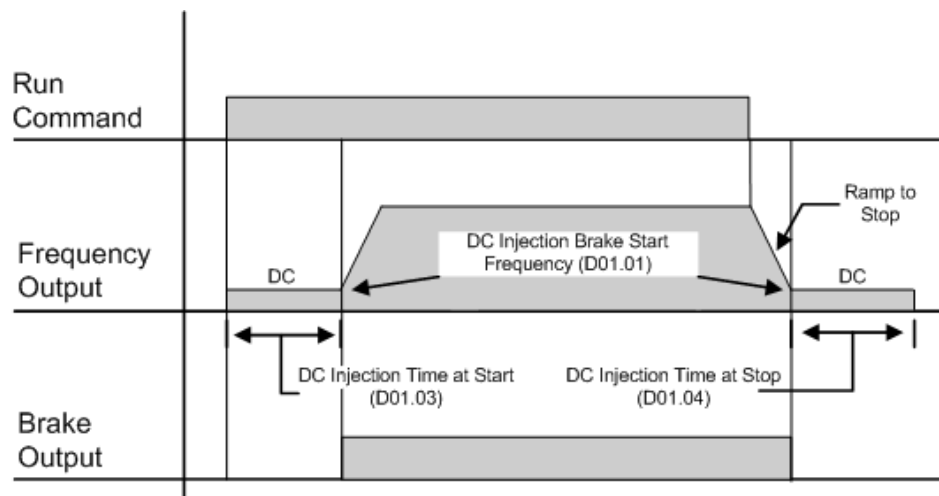

Figure 5-22: DC Braking Sequence

<b>Parameter Code</b>	<b>Name</b>	<b>Function</b>	<b>Range</b>	<b>Initial Value</b>	<b>Access Level</b>
D01.08	Magnetic Flux Compensation	Sets the magnetic flux compensation as a percentage of the no load current value (E02.03).	0000–1000	0000	Adv
D01.15	Mechanical Weakening Detection Speed Level	Changes the DC Injection braking reference one second after start. Disabled when set to zero.	000–100%	050	Adv

## Automatic Slip Compensation

As the load becomes larger, the motor speed is reduced and the motor slip increases. The slip compensation function keeps the motor speed constant under varying load conditions. D02.01 sets the slip compensation gain. When the gain is “1.0”, the output frequency is increased by 1% of the E01.06 setting at rated current. A setting of “0.0” results in no slip compensation.

Parameter Code	Name	Function	Range	Initial Value	Access Level
D02.01	Slip Compensation Gain	Slip compensation multiplier.	0.0–2.5	1.0 (OLV) 0.0 (V/f)	Adv
D02.02	Slip Compensation Time	Slip compensation primary delay time	0–10000 ms	200 (OLV) 2000 (V/f)	Adv
D02.03	Slip Compensation Limit	Slip compensation limit	0–250%	200	Adv
D02.04	Slip Compensation Regen	Slip compensation during regeneration <i>00 Disabled</i> <i>01 Enabled</i>	00, 01	00	Adv
D02.05	Slip Compensation V/f	Slip Compensation at V/f setting <i>00 Include</i> <i>01 Exclude</i>	00, 01	00	Adv
D02.06	Magnetic Flux Characteristic	Magnetic Flux Characteristic Calculation <i>00 Include</i> <i>01 Exclude</i>	00, 01	00	Adv

## Torque Compensation

The motor torque requirement changes according to load conditions. Full-range automatic torque boost adjusts the voltage of the V/f pattern according to the required torque. The IMPULSE•G+ Mini automatically adjusts the voltage during constant-speed operation as well as during acceleration. See below, Figure 5-23.

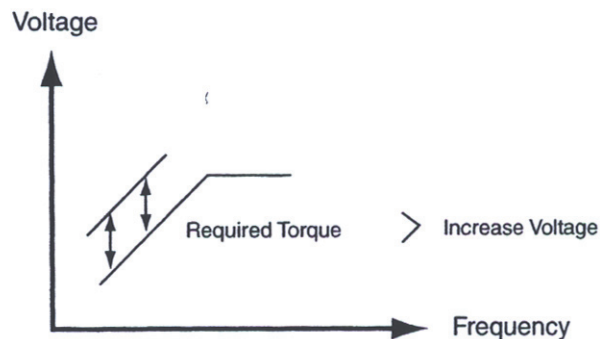

**Figure 5-23: Torque Characteristics**

The required torque is calculated by the inverter. This ensures trip-less operation and power savings.

Output voltage  $\propto$  Torque compensation gain x Required torque



When more torque is needed, increase the torque compensation gain in one-tenth (0.1) increments. Increase the setting when the wiring distance between the inverter and the motor is 100ft. or longer. If the motor generates excessive vibration or oscillates, decrease the torque compensation.

Increasing torque compensation gain increases motor torque, but an excessive increase may cause the following:

- Inverter fault trips due to motor overexcitation and/or
- Motor overheat or excessive vibration

Increase the torque compensation time constant in 10ms increments when the motor's output current is unstable. Decrease this value when speed response is slow.

<b>Parameter Code</b>	<b>Name</b>	<b>Function</b>	<b>Range</b>	<b>Initial Value</b>	<b>Control Method</b>	<b>Access Level</b>
D03.01	Torque Compensation Gain	Torque compensation multiplier.	0.00–2.50	1.00	V/f or OLV	Basic/Adv
D03.02	Torque Compensation Time	Torque compensation time.	0.00–10000 ms	60 (OLV)* 200 (V/f)	V/f or OLV	Adv
D03.03	Forward Torque Compensation @ Start	FWD compensation at start.	0.0–200%	0.0	OLV	Adv
D03.04	Reverse Torque Compensation @ Start	REV compensation at start.	-200–0.0%	0.0	OLV	Adv
D03.05	Torque Compensation Delay Time	Torque compensation delay time at start (disabled if 4 ms or less)	0–200 ms	10ms	OLV	Adv
D03.06	Torque Compensation Delay Time 2	Starting Torque Start-Up Time (ms)	0–10000 ms	150	OLV	Adv

\* See N02.05 for the setting D03.02 (Table 5-17) OLV Stabilization Level

## Dwell Function

The Dwell Function is used to temporarily hold the output frequency at a set reference for a set time. This function can be used when driving a motor with a heavy starting load. This pause in acceleration reduces traditionally high starting current. Enable by setting H01.01–H01.07 = 65.

*NOTE: This function is only available when using Braketronic (A01.03 = 06).*

Parameter Code	Name	Function	Range	Initial Value	Access Level
D08.01	Dwell Reference @ Start	Sets Dwell frequency reference at start.	0.0–150.0 Hz	0.0	Adv
D08.02	Dwell Time @ Start	Sets the time duration for the Dwell function at start.	0.0–10.0 sec	0.0	Adv
D08.03	Dwell Reference @ Stop	Sets Dwell frequency reference at stop.	0.0–150.0 Hz	0.0	Adv
D08.04	Dwell Time @ Stop	Sets the time duration for the Dwell function at stop.	0.0–10.0 sec	0.0	Adv

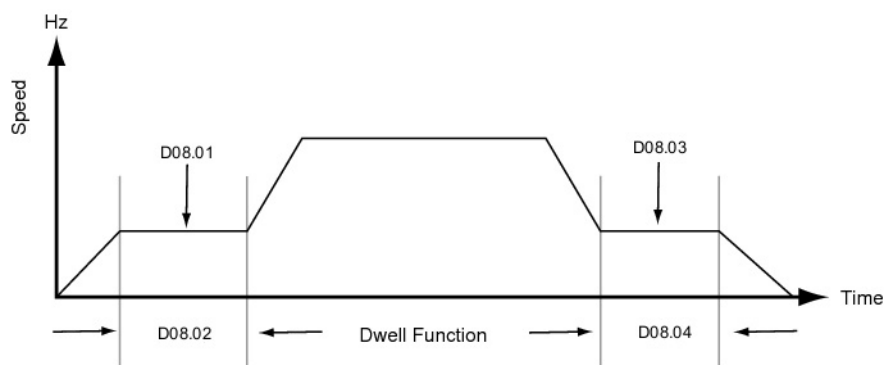

**Figure 5-24: Dwell Function**

## S-Curve Acceleration/Deceleration

An S-Curve pattern is used to reduce shock and provide smooth transitions during machine acceleration and deceleration. S-Curve characteristic time is the time from the output frequency to the set accel/decel time. See S-Curve Characteristic timing diagrams below and on the following page.

Parameter Code	Name	Function	Range	Initial Value	Access Level
D09.01	S-Curve Accel @ Start	Sets S-Curve time at Accel start	0.00–10.0 sec	0.50*	Basic/Adv
D09.02	S-Curve Accel @ End	Sets S-Curve time at Accel end	0.00–10.0 sec	0.50*	Basic/Adv
D09.03	S-Curve Decel @ Start	Sets S-Curve time at Decel start	0.00–10.0 sec	0.50*	Basic/Adv
D09.04	S-Curve Decel @ End	Sets S-Curve time at Decel end	0.00–10.0 sec	0.20	Basic/Adv

\*Initial value is determined by X-Press Programming (Table 4.1 to 4.2).

Figure 5-25 shows FWD/REV run switching during deceleration to stop. The S-Curve function will add time to the acceleration and deceleration.

Total time to acceleration from minimum frequency to maximum frequency (total acceleration) is:

$$\text{Total Acceleration Time (s)} = B05.01 + \left( \frac{(D09.01 + D09.02)}{2} \right)$$

Total time to deceleration from maximum frequency to minimum frequency (total deceleration) is:

$$\text{Total Deceleration Time (s)} = B05.02 + \left( \frac{(D09.03 + D09.04)}{2} \right)$$



**CAUTION**

Accel/Decel times will be extended.

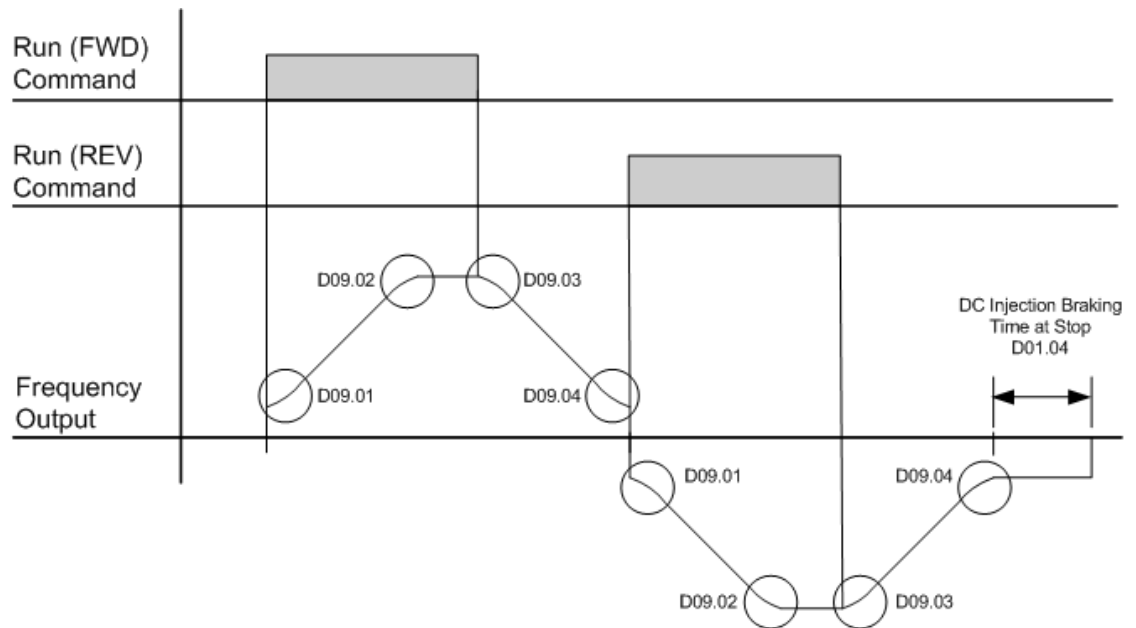

Figure 5-25: S-Curve Characteristics–FWD/REV Operation

## Carrier Frequency

Parameter Code	Name	Function	Range	Initial Value	Access Level
D10.01	CT/VT Selection	Constant Torque/Variable Torque Selection <i>00 Heavy Duty</i> <i>01 Normal Duty</i>	00, 01	00	Adv
D10.02	Carrier Frequency Selection	Carrier Frequency Selection <i>00 2 kHz (low noise)</i> <i>01 2 kHz</i> <i>02 5.0 kHz</i> <i>03 8.0 kHz</i> <i>04 10.0 kHz</i> <i>05 12.5 kHz</i> <i>06 15.0 kHz</i> <i>07 Swing PWM1</i> <i>08 Swing PWM2</i> <i>09 Swing PWM3</i> <i>0A Swing PWM4</i> <i>0F Custom (determined by the settings of D10.03–D10.06)</i>	00–0F	01	Adv
D10.03	Carrier Frequency Upper Limit	Carrier Frequency Upper Limit	1.0–15.0 kHz	2.0	Adv
D10.04	Carrier Frequency Lower Limit	Carrier Frequency Lower Limit	1.0–15.0 kHz	2.0	Adv
D10.05	Carrier Frequency Gain	Carrier Frequency Gain	00–99	00	Adv

## Hunting Prevention

Occasionally, in an application, resonance between the internal control system and the mechanical system causes current instability. This is called hunting, and may cause a crane to vibrate at a lower speed (up to 30 Hz) and light load. The hunting prevention function monitors the motor flux and uses a special control circuit to “smooth out” any peaks in the output current wave form.

Increase the set value of D11.02 when hunting is present while driving a light load. Decrease the set value of D11.02 when the motor vibrates or stalls while driving a heavy load.

<b>Parameter Code</b>	<b>Name</b>	<b>Function</b>	<b>Range</b>	<b>Initial Value</b>	<b>Control Method</b>	<b>Access Level</b>
D11.01	Hunt Prevention Selection	Enable/Disable Hunt Prevention function <i>00 Disable</i> <i>01 Enable</i>	00, 01	01	V/f	Adv
D11.02	Hunt Prevention Gain	Hunting Prevention Gain	0.00–2.50	1.00	V/f	Adv
D11.03	Hunt Prevention Time Constant	Hunting Prevention Time Constant	000–500ms	10	V/f	Adv
D11.05	Hunt Prevention Gain in Reverse	Reverse Hunting Prevention Gain	0.00–2.50	0.00	V/f	Adv

# Motor Parameters

Motor data such as full load amps and V/f patterns are selected with the following parameters. These parameters include the ability to select and set up custom V/f patterns for the type of motor used.

- E1 V/f Pattern
- E2 Motor Set-up

## Voltage/Frequency Pattern

Parameter Code	Name	Function	Range	Initial <sup>(1)</sup> Value	Access Level
E01.01	Input Voltage	Sets input voltage	155–255/ 310–510	230 460	Basic/Adv

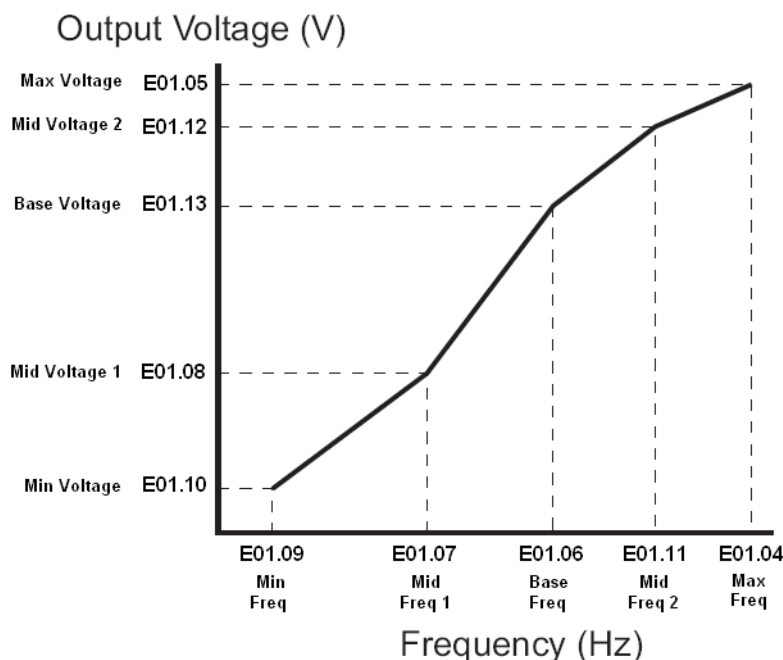

**Figure 5-26: E01.01 Input Voltage**

- Factory setting is 230 (230V units) or 460 (460V units).
- When E01.11 = 0, then the value of E01.11 is not used.
- When E01.12 = 0, then the value of E01.12 is not used.
- When E01.13 = 0, then the value of E01.13 is not used.

An OPE10 error will occur if the following conditions are not met:

$$E01.05 \geq E01.12 \geq E01.13 \geq E01.08 \geq E01.10$$

$$E01.04 \geq E01.11 \geq E01.06 \geq E01.07 \geq E01.09$$

The setting E01.01 adjusts the overvoltage level, braking transistor turn on level, and the stall prevention level during deceleration.

**Table 5-3:**

Inverter Voltage	E1-01 Setting	Overvoltage Trip		Braking Transistor	
		Trip	Reset	On	Off
230	150-255	400V	380V	380V	375V
460	≥400	800V	760V	760V	750V
460	<400	720V	680V	660V	650V

**Table 5-4: V/f Parameters**

Parameter Code	Name	Function	Range	Initial Value	Access Level
E01.03	V/f Selection	Selection V/f Pattern	00–0F, FF	04*	Basic/Adv
E01.04 <sup>(3)</sup>	Max Frequency	Maximum Frequency	40.0–150.0 Hz	**	Basic/Adv
E01.05 <sup>(2)</sup>	Max Voltage	Maximum Voltage	0.0–510.0 V	**	Basic/Adv
E01.06	Base Frequency	Motor Base Frequency	0.0–150.0 Hz	**	Basic/Adv
E01.07	Mid Frequency A	Midpoint Output Frequency A	0.0–150.0 Hz	**	Basic/Adv
E01.08 <sup>(2)</sup>	Mid Voltage A	Midpoint Frequency Voltage A	0.0–510.0 V	**	Basic/Adv
E01.09	Min Frequency	Minimum Frequency	0.0–150.0 Hz	**	Basic/Adv
E01.10 <sup>(2)</sup>	Min Voltage	Minimum Voltage	0.0–510.0 V	**	Basic/Adv
E01.11	Mid Frequency B	Midpoint Output Frequency B	0.0–150.0 Hz	**	Basic/Adv
E01.12 <sup>(2)</sup>	Mid Voltage B	Midpoint Output Voltage B	0.0–510.0 V	**	Basic/Adv
E01.13 <sup>(2)</sup>	Base Voltage	Motor Base Voltage	0.0–510.0 V	** ***	Basic/Adv

\* Initial value determined by X-Press Programming

\*\* Initial value determined by voltage class and setting of E01.03. See Tables 5-5 and 5-6.

\*\*\* This value is automatically set during Auto-Tuning.

<sup>(1)</sup> The initial value displayed here is for 460V class drives.

<sup>(2)</sup> For 230V class units, the value is half that of 460V class units.

<sup>(3)</sup> To change E01.04 “Max Frequency,” E01.03 must first be set to “0F”, or pick a V/f pattern from Table 5-4 or 5-5.

**Table 5-5: Voltage/Frequency Pattern Options for 230 V Class**

	<b>E01.04</b>	<b>E01.05</b>	<b>E01.06</b>	<b>E01.07</b>	<b>E01.08</b>	<b>E01.09</b>	<b>E01.10</b>	<b>E01.11</b>	<b>E01.12</b>	<b>E01.13</b>
<b>E01.03</b>	<b>Hz</b>	<b>V</b>	<b>Hz</b>	<b>Hz</b>	<b>V</b>	<b>Hz</b>	<b>V</b>	<b>Hz</b>	<b>V</b>	<b>V</b>
00 <sup>(4)</sup>	60.0	230.0	60.0	3.0	15.0	1.3	8.1	0.0	0.0	0.0
01	60.0	230.0	60.0	3.0	16.1	1.3	9.2	0.0	0.0	0.0
02	60.0	230.0	60.0	3.0	17.3	1.3	10.4	0.0	0.0	0.0
03	60.0	230.0	60.0	3.0	18.4	1.3	11.5	0.0	0.0	0.0
04 <sup>(5)</sup>	60.0	230.0	60.0	3.0	19.6	1.3	12.7	0.0	0.0	0.0
05	60.0	230.0	60.0	3.0	20.7	1.3	13.8	0.0	0.0	0.0
06	60.0	230.0	60.0	3.0	21.9	1.3	15.0	0.0	0.0	0.0
07	60.0	230.0	60.0	3.0	23.0	1.3	16.1	0.0	0.0	0.0
08	60.0	230.0	60.0	3.0	24.2	1.3	17.3	0.0	0.0	0.0
09	72.0	230.0	60.0	3.0	16.1	1.3	9.2	0.0	0.0	0.0
0A	72.0	230.0	60.0	3.0	17.8	1.3	10.9	0.0	0.0	0.0
0B	72.0	230.0	60.0	3.0	19.6	1.3	12.7	0.0	0.0	0.0
0C	90.0	230.0	60.0	3.0	16.1	1.3	9.2	0.0	0.0	0.0
0D	90.0	230.0	60.0	3.0	17.8	1.3	10.9	0.0	0.0	0.0
0E	90.0	230.0	60.0	3.0	19.6	1.3	12.7	0.0	0.0	0.0
0F (V/f)	60.0	230.0	60.0	3.0	19.6	1.3	12.7	0.0	0.0	0.0
0F (OLV)	60.0	230.0	60.0	3.0	13.8	0.5	2.9	0.0	0.0	0.0

**Table 5-6: Voltage/Frequency Pattern Options for 460 V Class**

	<b>E01.04</b>	<b>E01.05</b>	<b>E01.06</b>	<b>E01.07</b>	<b>E01.08</b>	<b>E01.09</b>	<b>E01.10</b>	<b>E01.11</b>	<b>E01.12</b>	<b>E01.13</b>
<b>E01.03</b>	<b>Hz</b>	<b>V</b>	<b>Hz</b>	<b>Hz</b>	<b>V</b>	<b>Hz</b>	<b>V</b>	<b>Hz</b>	<b>V</b>	<b>V</b>
00 <sup>(4)</sup>	60.0	460.0	60.0	3.0	29.9	1.3	16.1	0.0	0.0	0.0
01	60.0	460.0	60.0	3.0	32.2	1.3	18.4	0.0	0.0	0.0
02	60.0	460.0	60.0	3.0	34.5	1.3	20.7	0.0	0.0	0.0
03	60.0	460.0	60.0	3.0	36.8	1.3	23.0	0.0	0.0	0.0
04 <sup>(5)</sup>	60.0	460.0	60.0	3.0	39.1	1.3	25.3	0.0	0.0	0.0
05	60.0	460.0	60.0	3.0	41.4	1.3	27.6	0.0	0.0	0.0
06	60.0	460.0	60.0	3.0	43.7	1.3	29.9	0.0	0.0	0.0
07	60.0	460.0	60.0	3.0	46.0	1.3	32.2	0.0	0.0	0.0
08	60.0	460.0	60.0	3.0	48.3	1.3	34.5	0.0	0.0	0.0
09	72.0	460.0	60.0	3.0	32.2	1.3	18.4	0.0	0.0	0.0
0A	72.0	460.0	60.0	3.0	35.6	1.3	21.8	0.0	0.0	0.0
0B	72.0	460.0	60.0	3.0	39.1	1.3	25.3	0.0	0.0	0.0
0C	90.0	460.0	60.0	3.0	32.2	1.3	18.4	0.0	0.0	0.0
0D	90.0	460.0	60.0	3.0	35.6	1.3	21.8	0.0	0.0	0.0
0E	90.0	460.0	60.0	3.0	39.1	1.3	25.3	0.0	0.0	0.0
0F (V/f)	60.0	460.0	60.0	3.0	39.1	1.3	25.3	0.0	0.0	0.0
0F (OLV)	60.0	460.0	60.0	3.0	27.6	0.5	5.8	0.0	0.0	0.0

<sup>(4)</sup> Default for Traverse Motion (A01.03 = 00) and Braketric (A01.03 = 04)

<sup>(5)</sup> Default for Hoist Motion (A01.03 = 01)



## Motor Set-up

E2 constants define motor parameters. Normally, the default settings for E2 constants are determined by KVA selection (O02.04). In open loop vector control the E2 constants will be set automatically during auto-tuning. If the control method is V/f (A01.02 = 00), the motor rated current should be entered into E02.01.

If auto-tuning cannot be performed, some E2 constants can be calculated using the motor's nameplate information.

Motor rated slip frequency (E02.02) can be calculated by using the following equation:

$$f_s = f - \frac{(N * P)}{120}$$

Where...  $f_s$ : slip frequency (Hz)  
 $f$ : rated frequency (Hz)  
 $N$ : rated motor speed (rpm)  
 $P$ : number of motor poles

Motor terminal resistance E02.05 can be calculated by using the following equation:

$$r_t = r_p * \frac{273 + \left[ \frac{(25^\circ\text{C} + T_i)}{2} \right]}{273 + T_i}$$

Where...  $r_t$ : motor terminal resistance  
 $r_p$ : Phase-to-Phase resistance at insulation class temperature  
 $T_i$ : insulation class temperature (°C)

Parameter Code	Name	Function	Range	Initial Value	Access Level
E02.01	Motor Rated FLA	Motor-rated current full load amps	0.01–70.0 A	*	Basic/Adv
E02.02	Motor Rated Slip	Motor-rated slip frequency	0.00–20.00 Hz	**	Adv
E02.03	No-Load Current	Motor no-load current	0.0–70.0 A	**	Adv
E02.04	Number of Poles	Number of poles in motor	02–48	04	Adv
E02.05	Terminal Resistance	Motor terminal resistance	0.000–65.000 Ω	**	Adv
E02.06	Leakage Inductance	Motor Leakage Inductance	0.0–40.0%	**	Adv
E02.07	Saturation Comp 1	Core-Saturation Compensation Coefficient 1	0.00–0.50	**	Adv
E02.08	Saturation Comp 2	Core-Saturation Compensation Coefficient 2	0.00–0.75	**	Adv
E02.09	Motor Mechanical Loss	Mechanical Torque Loss as a % of motor torque	0.0–10.0%	0.0	Adv
E02.10	Motor Iron Loss of Torque Compensation		0–65535	**	Adv
E02.11	Motor Rated Power	Rated output	0.0–20.0 HP	**	Adv
E02.12	Saturation Comp 3	Core-Saturation Compensation Coefficient 3	1.30–5.00%	**	Adv

\* Initial value is determined by O02.04 (kVA Selection)

\*\* This value is automatically set during auto tuning

# Option Parameters

- F1 Pulse Generated Option Set Up

## Pulse Generated (PG) Control

The following option parameters are used to set and control the action for the Pulse Generated (PG) input and output, including overspeed detection. These parameters become visible when the pulse generator function (H06.01) is set to 03 and the control method is set to OLV (A01.02 = 02).

Parameter Code	Name	Function	Range	Initial Value	Access Level
F01.02	Pulse Feedback Loss	Stopping Method for PG disconnection <i>00 Decel to Stop (by B05.02)</i> <i>01 Coast to Stop</i> <i>02 Fast Stop (by B05.08)</i> <i>03 Alarm Only</i>	00–03	01	Adv
F01.03	Operation at Overspeed	Stopping Method for PG Overspeed <i>00 Decel to Stop (by B05.02)</i> <i>01 Coast to Stop</i> <i>02 Fast Stop (by B05.08)</i> <i>03 Alarm Only</i>	00–03	01	Adv
F01.04	Operation at Deviation	Stopping Method for PG at excessive deviation <i>00 @ speed agree - Decel (by B05.02)</i> <i>01 @ speed agree - Coast to Stop</i> <i>02 @ speed agree - Fast Stop (by B05.08)</i> <i>03 @ speed agree - Alarm only</i> <i>04 @ Run - Decel to Stop (by B05.02)</i> <i>05 @ Run - Coast to Stop</i> <i>06 @ Run - Fast Stop (by B05.08)</i> <i>07 Alarm only (Dev-1 and Dev-2 Alarm)</i>	00–07	05	Adv
F01.08	Overspeed Detection Level	PG Overspeed Detection Level	0–120%	105	Adv
F01.09	Overspeed Detection Time	PG Overspeed Detection Time	0.0–2.0sec	0.0	Adv
F01.10	Excessive Speed Detection Level	Excessive Speed Deviation Level	0–50%	10	Adv
F01.11	Excessive Speed Detection Time	Excessive Speed Deviation Detection Time	0.0–10.0sec	0.3	Adv
F01.14	PGO Detection Time	PGO Detection Time	0.0–10.0sec	0.5	Adv

# Terminal Parameters

There are both digital and analog inputs and outputs that can be programmed for customized operation and sequencing. These include input and output terminal selection along with serial communication. Listed below are the parameters in this section that are customizable for your system.

- H1 Digital Inputs
- H2 Digital Outputs
- H3 Analog Inputs
- H4 Analog Outputs
- H5 Serial Communication Set-up
- H6 Pulse Inputs

## Digital Inputs

The IMPULSE•G+ Mini has seven multi-function contact inputs for the set-up of numerous functions. The following table lists the function selections for the multi-function contact inputs (terminals S1 to S7) and indicates the control modes during which each function can be enabled. An OPE03 error will occur if the same function is programmed in more than one terminal at the same time.

Parameter Code	Name	Function	Reference Page Number	Range	Initial Value	Access Level
H01.01	Terminal S1 Select	Selects the multi-function inputs. Setting for S1.	--	00–81	80*	Basic/Adv
H01.02	Terminal S2 Select	Setting for S2.	--	00–81	81*	Basic/Adv
H01.03	Terminal S3 Select	Setting for S3.	--	00–81	00*	Basic/Adv
H01.04	Terminal S4 Select	Setting for S4.	--	00–81	01*	Basic/Adv
H01.05	Terminal S5 Select	Setting for S5.	--	00–81	0F*	Basic/Adv
H01.06	Terminal S6 Select	Setting for S6.	--	00–81	0F*	Basic/Adv
H01.07	Terminal S7 Select	Setting for S7.	--	00–81	0F*	Basic/Adv
	00 Multi-Step Ref 2	Multi-Step Speed 2.	5-3			Basic/Adv
	01 Multi-Step Ref 3	Multi-Step Speed 3.	5-3			Basic/Adv
	02 Multi-Step Ref 4	Multi-Step Speed 4.	5-3			Basic/Adv
	03 Multi-Step Ref 5	Multi-Step Speed 5.	5-3			Basic/Adv
	04 Speed Hold 2	Hold function (2nd step of Three-Step Infinitely Variable).	--			Basic/Adv
	05 Accel Command	Acceleration function (2nd step of Two-Step Infinitely Variable or 3rd step of Three-Step Infinitely Variable).	5-3			Basic/Adv
	06 Upper Limit 1 N.O.	Upper Limit - SLOW DOWN; Normally Open. UL1 - blinking	5-20			Basic/Adv
	07 Upper Limit 2 N.O.	Upper Limit - STOP; Normally Open. UL2 - blinking	5-20			Basic/Adv
	08 Lower Limit 1 N.O.	Lower Limit - SLOW DOWN; Normally Open. LL1 - blinking	5-20			Basic/Adv

\* = Parameter defaults changed by X-Press Programming

Parameter Code	Name	Function	Reference Page Number	Range	Initial Value	Access Level
09	Lower Limit 2 N.O.	Lower Limit - STOP; Normally Open. LL2 - blinking	5-20			Basic/Adv
0A	Upper Limit 1 N.C.	Upper Limit - SLOW DOWN; Normally Closed. UL1 - blinking	5-20			Basic/Adv
0B	Upper Limit 2 N.C.	Upper Limit - STOP; Normally Closed. UL2 - blinking	5-20			Basic/Adv
0C	Lower Limit 1 N.C.	Lower Limit - SLOW DOWN; Normally Closed. LL1 - blinking	5-20			Basic/Adv
0D	Lower Limit 2 N.C.	Lower Limit - STOP; Normally Closed. LL2 - blinking	5-20			Basic/Adv
0E	M-Speed Gain 1	Micro-Speed positioning control multiplier 1. Gain is set by parameter C02.01 (has priority over MS2)	5-19			Adv
0F	Not used	No function - terminal is disabled	--			Basic/Adv
10	M-Speed Gain 2	Micro-Speed positioning control multiplier 2. Gain is set by parameter C02.02.	5-19			Adv
12	Weight Limit N.C.	Weighted Upper Limit (UL3); Stopping Method determined by C03.08.	5-20			Adv
13	Swift-Lift	Swift-Lift Enable (C06.01 = 2). Not available for Traverse Motion	5-24			Basic/Adv
14	Alt T-Lim Gain	Alternate Torque Limit Gain - C07.05. Use when load testing a hoist	5-28			Adv
15	Forward Jog	Uses B01.17 reference	5-3			Adv
16	Reverse Jog	Uses B01.17 reference	5-3			Adv
17	Forward Inch	Inch Control	5-32			Adv
18	Reverse Inch	Inch Control	5-32			Adv
19	Inch Repeat	Inch Control	5-32			Adv
1A	Acc/Dec 2	Acceleration and Deceleration Time Changeover 2 using B05.03 and B05.04	5-15			Basic/Adv
1B	Acc/Dec 3	Acceleration and Deceleration Time Changeover 3 using B05.12 and B05.13	5-15			Adv
1C	Acc/Dec 4	Acceleration and Deceleration Time Changeover 4 using B05.14 and B05.15	5-15			Adv
1D	Digital Chngover	Analog/Digital Reference Changeover B01.18 = 1 Open = Analog Closed = Digital	5-3			Adv
1F	Opt/Inv Switch	Option/Inverter Selection (Frequency and Run Reference from Option card. Closed = Option Card). Set B03.01, B03.02 = Terminals; set H01.0X = 1F	5-6			Adv

\* = Parameter defaults changed by X-Press Programming

Parameter Code	Name	Function	Reference Page Number	Range	Initial Value	Access Level
20 thru 2F	External Fault	Desired setting is possible. Input mode: N.O./N.C., Detection mode: Always/ During Run (See external fault response selection table 5-7)	5-51			Basic/Adv
30	Program Lockout	Program Lockout Closed: Parameters enabled to write Open: Parameters disabled to write other than freq. reference (U01.01)	--			Adv
31	Local/Remote Sw	Closed = Local	--			Adv
32	Ext BB N.O.	N.O.: Baseblock by ON. Immediate stop at STOP command; normally open	--			Basic/Adv
33	Ext BB N.C.	N.C.: Baseblock by OFF. Immediate stop at STOP command; normally closed	--			Basic/Adv
39	External OH2	Inverter overheat prediction (OH2 is shown by ON). Alarm only.	--			Adv
3A	Trm A1/A2 Enable	Multi-function analog input A1/ A2 Enable/Disable. When programmed, analog input A1/ A2 is enabled by ON.	--			Basic/Adv
3F	Fault Reset	Reset by ON	--			Basic/Adv
40	Fast Stop N.O.	Deceleration to stop by fast stop time B05.08 at ON	5-46			Adv
42	Fast Stop N.C.	Deceleration to stop by fast stop time B05.08 at OFF	5-46			Adv
43	Timer Enable	Function settings by C12.03, C12.04. It is set with timer function output [Multi- Function Output]	5-30			Adv
47	Analog Hold	Analog frequency reference Sample/Hold	--			Adv
4C	DCInj Braking	ON: DC injection braking command, once SFS reaches Zero Speed	--			Adv
53	Comm Test	Communication test mode - loopback test of modbus RS-422/485 interface	--			Adv
55	Drive Enable	When programmed, must be ON in order for Inverter Ready - Generates "Drive not Ready". "DNE" is displayed.	--			Adv
56	Klixon N.O.	When Closed, Reset run command, use stopping method B03.03, display oL8 - Klixon Alarm on Keypad	5-21			Adv
57	Klixon N.C.	When Open, Reset run command, use stopping method B03.03, display oL8- Klixon Alarm on Keypad	5-21			Adv
58	Brake Answer back	Generates BE0, BE4, BE5, alarm or fault conditions only when programmed to MFI (C08.04, C08.11)	5-29			Adv

\* = Parameter defaults changed by X-Press Programming

<b>Parameter Code</b>	<b>Name</b>	<b>Function</b>	<b>Reference Page Number</b>	<b>Range</b>	<b>Initial Value</b>	<b>Access Level</b>
59	<i>Alternate Upper Frequency</i>	<i>Alternate Reference Upper Limit Frequency</i>	5-5			Basic/Adv
5A	<i>Maintenance Reset</i>	<i>Reset Maintenance Timer (C12.05 - C12.06, U01.52)</i>	5-31			Adv
5B	<i>BE6 Up Speed Limit</i>	<i>Limit Fref to C08.17 (BE6 Up Speed Limit)</i>	--			Adv
5F	<i>Phantom Fault N.C.</i>	<i>Stops motion based C03.09 but does not change Keypad display. Stop L.E.D. on JVOP blinks</i>	5-21			Adv
62	<i>Weight Limit N.O.</i>	<i>Weighted Upper Limit (UL3). Stopping Method determined by C03.08</i>	5-20			Adv
63	<i>Phantom Fault N.O.</i>	<i>Stops motion based C03.09 but does not change Keypad display. STOP L.E.D. on JVOP blinks</i>	5-21			Adv
65	<i>Dwell Enable</i>	<i>Enables/Disables Dwell function. When H01.0X = 65H, OFF = Disabled.</i>	5-38			Adv
69	<i>LC Disable</i>	<i>When the input is active, the Load Check function will be disabled.</i>	--			Adv
70	<i>Torque Detection</i>	<i>When H01.0X = 70H, Overtorque/Undertorque detection is enabled and disabled by MFDI. When the input is closed, Overtorque/Undertorque detection is enabled</i>	--			Adv
80	<i>Forward Run.</i>	<i>Forward Run Command</i>	5-4			Basic/Adv
81	<i>Reverse Run</i>	<i>Reverse Run Command</i>	5-4			Basic/Adv

*\* = Parameter defaults changed by X-Press Programming*

## External Fault Response Selection

It is sometimes desirable to have at least one external fault input to the drive. To properly program a multi-function input (H01.01 to H01.07) for this purpose an external fault response must be selected. The table below shows the possible selections for an external fault response.

**Table 5-7:**

External Fault Selection								MFI Setting Result
Input Level Selection		Detection Method		External Fault Action				
N.O. <sup>(1)</sup>	N.C. <sup>(1)</sup>	Always	During Run	Ramp to Stop	Coast to Stop	Fast-stop <sup>(2)</sup>	Alarm Only	
√		√		√				20
√		√			√			24
√		√				√		28
√		√					√	2C
√			√	√				22
√			√		√			26
√			√			√		2A
√			√				√	2E
	√	√		√				21
	√	√			√			25
	√	√				√		29
	√	√					√	2D
	√		√	√				23
	√		√		√			27
	√		√			√		2B
	√		√				√	2F

(1) N.O. = normally open contact; N.C. = normally closed contact

(2) Uses B05.08 timer

## Digital Outputs

The IMPULSE•G+ Mini has three multi-function control outputs (one relay, two open collector) for indicating various conditions. The following table lists the function selections for the multi-function contact outputs and indicates the control modes during which each function can be enabled.

Parameter Code	Name	Function	Reference		Initial Value	Access Level
			Page Number	Range		
H02.01	Output Contactor (MC-MB-MA) select	Digital Output 1 Function	--	000–1FF	000	Basic
H02.02	Output Terminal P1 Select	Digital Output 2 Function	--	000–1FF	000	Basic
H02.03	Output Terminal P2 Select	Digital Output 3 Function	--	000–1FF	00F	Basic
	000 Brake Release	Closed when the drive provides a voltage or frequency is output	--			Basic/Adv
	001 Zero Speed	Closed when the output frequency is below B02.02 or D01.01	--			Basic/Adv
	002 Fref/Fout Agree 1	Closed when Frequency Reference and Frequency Output agree	--			Adv
	003 Fref/Set Agree 1	Closed when Output Frequency Reference equals L04.01	5-70			Adv
	004 Freq Detect 1	Closed when the output frequency is < L04.01.	5-70			Basic/Adv
	005 Freq Detect 2	Closed when the output frequency is > L04.01.	5-70			Basic/Adv
	006 Inverter Ready	Closed when an inverter is not in a fault state	--			Adv
	007 DC Bus Undervolt	Closed when DC Bus voltage drops below UV trip point	--			Adv
	008 BaseBlk N.O.	Closed when the inverter is not outputting voltage	--			Adv
	009 Frequency Reference Source	Closed when the frequency reference is input from the digital operator (O02.01)	5-85			Adv
	00A Local Operation	Closed when the RUN command is input from the digital operator.	--			Adv
	00B Trq Det 1 N.O.	Closed when torque > L06.02	5-73			Basic/Adv
	00DDB Overheat	Closed when inverter displays "RH" or "RR" fault	--			Adv
	00E Fault	Closed during a major fault.	--			Basic/Adv
	00F Not Used	No function	--			Basic/Adv
	010 Minor Fault	Closed during minor fault or alarm	--			Adv
	011 Reset Cmd Active	Closed when a reset command is present on the terminals	--			Adv
	012 Timer Output	See Timer function output	5-30			Adv
	013 Fref/Fout Agree 2	Closed when output frequency = frequency reference	5-70			Adv
	014 Fref/Set Agree 2	Closed when output frequency = L04.03	5-70			Adv



Parameter Code	Name	Function	Reference		Initial Value	Access Level
			Page Number	Range		
015	Freq Detect 3	Closed when output frequency $\leq L04.03$	5-70			Adv
016	Freq Detect 4.	Closed when output frequency $\geq L04.03$	5-70			Adv
017	Trq Det 1 N.C.	Open when torque > L06.02 for longer than L06.03 time	5-73			Basic/Adv
018	Trq Det 2 N.O.	Closed when torque > L06.05	5-74			Adv
019	Trq Det 2 N.C.	Open when torque > L06.05	5-74			Adv
01A	Forward Direction	Closed when running FWD/UP	--			Adv
01B	Reverse Direction	Closed when running REV/DOWN	--			Adv
01C	Swift Active	Closed when Swift Lift is active	5-24			Adv
01D	BaseBlk N.C.	Open during baseblock 2	--			Adv
020	Auto-Rst Attempt	Closed when auto reset is enabled	5-77			Adv
021	Overload OLI	Closed when an OLI Overload fault code occurs	5-61			Adv
022	Overheat Prealarm	Closed when "OH" is displayed on keypad	5-75			Adv
023	Torque Limit	Closed when current Torque Limit is reached	5-28			Adv
026	Run Cmd is input	Closed when either a Fwd or Rev Run Command is active	--			Adv
027	Load Check Det	Closed when Load Check detected	5-22			Adv
029	Upper Limit	Closed when Upper Limit-SLOW DOWN or Upper Limit STOP is input	5-20			Adv
02A	During Run1	Closed when the Inverter Outputting Voltage	--			Adv
02B	During Fast Stop	Closed During Fast Stop	--			Adv
02F	Load Weakening	Closed during Load Weakening	5-12			Adv
030	Lower Limit	Closed when Lower Limit-SLOW DOWN or Lower Limit STOP is input	5-20			Adv
031	Upper/Lower Limit	Closed when Upper Limit-SLOW DOWN or Upper Limit STOP or Lower Limit-SLOW DOWN or Lower Limit STOP is input	5-20			Adv
035	Load Check Alarm Detection	Output will close when a Load Check condition is detected	--			Adv
037	Maintenance	Closed when the timer reaches C12.02	5-30			
039	Drive Enable	Closed when drive enable is active	--			Adv
03A	Overheat Pre Alarm Time Limit	Closed when OH Pre Alarm Time Limit is reached	5-75			Adv
03D	During Speed Search	Closed during Speed Search	--			Adv
03F	Klixon	Closed when MFDI 56 or 57 is on - motor is overheating	5-21			Adv

Parameter Code	Name	Function	Reference		Initial Value	Access Level
			Page Number	Range		
	040 ~ FF Fault Annunciate	Closed on specific faults	--			Adv
101	Inverse Zero Speed	Open when the output frequency is below B02.02 or D01.01	--			Basic/Adv
102	Inverse Frequency Agree 1	Open when Frequency Reference and Frequency Output agree	--			Adv
103	Inverse Frequency Set 1	Open when Output Frequency Reference equals L04.01	5-70			Adv
104	Inverse Freq Detect 1	Open when output frequency is < L04.01.	5-70			Basic/Adv
105	Inverse Freq Detect 2	Open when output frequency is > L04.01.	5-70			Basic/Adv
106	Inverse Inverter Ready	Open when an inverter is not in a fault state	--			Adv
107	Inverse DC Bus Undervolt	Open when DC Bus voltage drops below UV trip point	--			Adv
108	Inverse Baseblock N.O.	Open when the inverter is not outputting voltage	--			Adv
109	Inverse Frequency Reference Source	Open when the frequency reference is input from the digital operator (O02.01)	5-85			Adv
10A	Inverse Local Operation	Open when the RUN command is input from the digital operator	--			Adv
10B	Inverse Trq Det 1 N.O.	Open when torque > L06.02	5-73			Basic/Adv
10D	Inverse DB Overheat	Open when inverter displays "RH" or "RR" fault	--			Adv
10E	Inverse Fault	Open during a major fault	--			Basic/Adv
110	Inverse Minor Fault	Open during minor fault or alarm	--			Adv
111	Inverse Reset Command Active	Open when a reset command is present on the terminals	--			Adv
112	Inverse Timer Output	See Timer function output	5-30			Adv
113	Inverse Freq Agree 2	Open when output frequency = frequency reference	5-70			Adv
114	Inverse Frq Set 2	Open when output frequency = L04.03	5-70			Adv
115	Inverse Frequency Detect 3	Open when output frequency ≤ L04.03	5-70			Adv
116	Inverse Frequency Detect 4	Open when output frequency ≥ L04.03	5-70			Adv
117	Inverse Torque Detect 1 N.C.	Closed when torque > L06.02 for longer than L06.03 time	5-73			Basic/Adv
118	Inverse Torque Detect 2 N.O.	Open when torque > L06.05	5-74			Adv
119	Inverse Torque Detect 2 N.C.	Closed when torque > L06.05	5-74			Adv
11A	Inverse Forward Direction	Open when running FWD/UP	--			Adv
11B	Inverse Reverse Direction	Open when running REV/DOWN	--			Adv

Parameter Code	Name	Function	Reference		Initial Value	Access Level
			Page Number	Range		
11C	Inverse Swift-Lift Active	Open when Swift Lift is active	5-24			Adv
11D	Inverse Baseblock N.C.	Closed during baseblock 2	--			Adv
120	Inverse Auto-Reset	Open when auto-reset is enabled	5-77			Adv
121	Inverse Overload OLI	Open when an OLI Overload fault code occurs	5-61			Adv
122	Inverse Overheat Pre-alarm	Open when "OH" is displayed on keypad	5-75			Adv
123	Inverse Torque Limit	Open when current Torque Limit is reached	5-28			Adv
126	Inverse Run Command is input	Open when either a Fwd or Rev Run Command is active	--			Adv
127	Inverse Load Check Detect	Open when Load Check detected	5-22			Adv
129	Inverse Upper Limit	Open when Upper Limit-SLOW DOWN or Upper Limit STOP is input	5-20			Adv
12A	Inverse During Run 1	Open when the Inverter Outputting Voltage	--			Adv
12B	Inverse During Fast Stop	Open During Fast Stop	5-12			Adv
12F	Inverse Load Weakening	Open during Load Weakening	--			Adv
130	Inverse Lower Limit	Open when Lower Limit-SLOW DOWN or Lower Limit STOP is input	5-20			Adv
131	Inverse Upper/Lower Limit	Open when Upper Limit-SLOW DOWN or Upper Limit STOP or Lower Limit-SLOW DOWN or Lower Limit STOP is input	5-20			Adv
135	Inverse Load Check Alarm Detection	Output will open when a Load Check condition is detected	--			Adv
137	Inverse Maintenance	Open when the timer reaches C12.02	5-30			Adv
139	Inverse Drive Enable	Open when drive enable is active	--			Adv
13A	Inverse Overheat Pre-Alarm Time Limit	Open when OH Pre Alarm Time Limit is reached	5-75			Adv
13D	Inverse During Speed Search	Open during Speed Search	--			Adv
13F	Inverse Klixon	Open when MFDI 56 or 57 is on - motor is overheating	5-21			Adv
140~1FF	Inverse Fault Annunciate	Open on specific faults	--			Adv

## Analog Inputs

The IMPULSE•G+ Mini has two analog inputs (two multi-function and one reference) for the external input of numerous references and limits.

Parameter Code	Name	Function	Range	Initial Value	Access Level
H03.01	Terminal A1 Signal Select	Voltage for Terminal A1 analog input signal	00	00	Basic/Adv
	<i>00 0VDC to 10VDC</i>				
H03.02	Terminal A1 Select	Assigns one of the following functions for the analog input Terminal A1.	00–1F	00	Basic/Adv
	<i>00 Frequency Bias</i>				Basic
	<i>01 Frequency Gain</i>				Adv
	<i>02 Aux Speed Reference 1</i>				Adv
	<i>03 Aux Speed Reference 2</i>				Adv
	<i>04 Output Voltage Bias</i>				Adv
	<i>07 OT/UT Detection Level</i>	<i>Overtorque Detection Level</i>			Adv
	<i>0E Motor Temperature</i>	<i>Used in conjunction with L01.03, L01.04 and L01.05</i>			Adv
	<i>0F Not used</i>	<i>Not Used</i>			Basic/Adv
	<i>10 Forward Torque Limit</i>				Adv
	<i>11 Reverse Torque Limit</i>				Adv
	<i>12 Regen Torque Limit</i>				Adv
	<i>15 FWD/REV Torque Limit</i>				Adv
	<i>1F Not Used</i>	<i>Not used</i>			Adv
H03.03	Terminal A1 Gain	Gain multiplier for Terminal A1 analog input signal	-999.9 – 999.9%	100.0	Basic/Adv
H03.04	Terminal A1 Bias	Bias multiplier for Terminal A1 analog input signal	-999.9 – 999.9%	000.0	Basic/Adv

Parameter Code	Name	Function	Range	Initial Value	Access Level
H03.09	Terminal A2 Signal Select	Selects the signal level for Terminal A2	00–03	02	Basic/Adv
	00	0VDC ~ 10VDC (switch S2 must be in the “V” position)			Basic/Adv
	02	4 to 20mA (switch S2 must be in the “I” position)			Basic/Adv
	03	0 to 20mA (switch S2 must be in the “I” position)			Basic/Adv
	NOTE: Switch between current or voltage inputs by using (S2) switch on the main board				
H03.10	Terminal A2 Select	Assigns one of the following functions for the analog input Terminal A2.	00–1F	00	Basic/Adv
	00	Frequency Bias			Basic
	01	Frequency Gain			Adv
	02	Aux Speed Reference 1			Adv
	03	Aux Speed Reference 2			Adv
	04	Output Voltage Bias			Adv
	07	OT/UT Detection Level	Overtorque Detection Level		Adv
	0E	Motor Temperature	Used in conjunction with L01.03, L01.04 and L01.05		Adv
	0F	Not used	Not Used		Basic/Adv
	10	Forward Torque Limit			Adv
	11	Reverse Torque Limit			Adv
	12	Regen Torque Limit			Adv
	15	FWD/REV Torque Limit			Adv
	1F	Not Used	Not used		Adv
H03.11	Terminal A2 Gain	Gain multiplier for terminal A2 analog input signal	-999.9 – 999.9%	100.0	Basic/Adv
H03.12	Terminal A2 Bias	Bias multiplier for terminal A2 analog input signal	-999.9 – 999.9%	000.0	Basic/Adv
H03.13	Analog Input Filter Time Constant	Analog input filter average time; analog delay time constant between Terminals A1 and A2	0.00-2.00sec	0.03	Basic/Adv

## Analog Outputs

The IMPULSE•G+Mini has two analog outputs for the external monitoring of drive conditions.

Parameter Code	Name	Function	Range	Initial Value	Access Level
H04.01	Terminal AM Select	Assigns one of the following functions for analog output Terminal AM.	101–162	102	Adv
	<i>101 Frequency Reference</i>				
	<i>102 Output Frequency</i>				
	<i>103 Output Current</i>				
	<i>105 Motor Speed (OLV only)</i>				
	<i>106 Output Voltage</i>				
	<i>107 DC Bus Voltage</i>				
	<i>108 Output Power (calculated in HP)</i>				
	<i>109 Torque Reference (OLV only)</i>				
	<i>115 Term A1 Level</i>				
	<i>116 Term A2 Level</i>				
	<i>120 SFS Output</i>				
	<i>154 Input Pulse Monitor</i>				
	<i>162 Not Used</i>				
H04.02	Terminal AM Gain	Gain multiplier for Terminal AM analog output signal	-999.9–999.9%	100.0	Adv
H04.03	Terminal AM Bias	Bias multiplier for Terminal AM analog output signal	-999.9–999.9%	000.0	Adv

## Serial Communication Set-up

The IMPULSE•G+ Mini uses terminals R<sup>+</sup>/R<sup>-</sup>, S<sup>+</sup>/S<sup>-</sup> to communicate MODBUS RTU (RS-485/422) protocol.

Parameter Code	Name	Function	Range	Initial Value	Access Level
H05.01	Serial Comm Address	Serial communication address (hexadecimal)	00–20	1F	Basic/Adv
H05.02	Serial Baud Rate	Sets the baud rate (bits per second)	00–08	03	Basic/Adv
	<i>00 1200 BPS</i>				
	<i>01 2400 BPS</i>				
	<i>02 4800 BPS</i>				
	<i>03 9600 BPS</i>				
	<i>04 19200 BPS</i>				
	<i>05 38400 BPS</i>				
	<i>06 57600 BPS</i>				
	<i>07 76800 BPS</i>				
	<i>08 115200 BPS</i>				
H05.03	Communication - Parity	Determines the parity	00–02	00	Basic/Adv
	<i>00 No parity</i>				
	<i>01 Even parity</i>				
	<i>02 Odd parity</i>				
H05.04	Communication - Error Stopping Method	Determines stopping method after a serial fault occurrence	00–03	04	Adv
	<i>00 Decel to Stop</i>				
	<i>01 Coast to Stop</i>				
	<i>02 Fast Stop</i>				
	<i>03 Alarm Only</i>				
H05.05	Communication - Error Detection Select	Enable/Disable serial fault detection	00, 01	01	Adv
	<i>00 Disabled</i>				
	<i>01 Enabled</i>				
H05.06	Transmit Wait Time	Send waiting time	05–65 ms	05	Adv
H05.07	RTS Control Sel	RTS Control enable/disable	00, 01	01	Adv
	<i>00 Disabled (RTS is always on)</i>				
	<i>01 Enabled (RTS is ON only when sending)</i>				
H05.09	Communication - Error Detection Time	Communication Error Detection Time	0.0–10.0	2.0	Adv
H05.10	Output Voltage Reference	Changes output voltage reference unit when reading register 0x25	00, 01	00	Adv
	<i>00 0.1V/unit</i>				
	<i>01 1V/unit</i>				

Parameter Code	Name	Function	Range	Initial Value	Access Level
H05.11	Communication Enter Function Select	Select whether or not an Enter Command is required to save parameter data to drive	00, 01	00	Adv
	00 Enter Command must be used (G+ Series 2/3 Method)				
	01 Enter Command not required (P3S2 method)				
H05.12	Run Command Method Selection	Select Run Command Method	00, 01	00	Adv
	00 Bit 0 = Start/Stop Forward Direction Bit 1 = Start/Stop Reverse Direction				
	01 Bit 0 = Start/Stop Bit 1 = Forward/Reverse Direction				

*NOTE: After changing any H05.XX parameter, power to the inverter must be cycled for the changes to take effect.*

*NOTE: After initial communication, if the inverter does not detect communication for H05.09 time, a communication fault will occur (CE Memobus ERR).*



## Pulse Inputs

Parameter Code	Name	Function	Range	Initial Value	Access Level
H06.01	Pulse Input Selection	Sets the function of the Pulse Input Terminal (RP) <i>00 Frequency Reference</i> <i>03 Encoder Feedback</i>	00, 03	00	Adv
H06.02	Pulse Input Scaling	Sets the number of pulses equal to the maximum output frequency	1,000 – 32,000 Hz	1440	Adv
H06.03	Pulse Input Gain	Sets the gain of the output frequency when the input frequency is at 100%	0.0 – 1,000.0%	100.0	Adv
H06.04	Pulse Input Bias	Sets the output frequency level when the input frequency is ONE	-100.0 – 100.0%	0.0	Adv
H06.05	Pulse Input Filter Time	Sets the input filter time delay constant in seconds	0.00–2.00 sec	0.10	Adv
H06.06	Pulse Monitor Selection	Selects which monitor output to use for the Pulse Train Monitor Output Terminal (MP). Ex: 102 means U01.02 (Output Frequency)	000, 031, 101, 102, 105, 120, 501, 502	102	Adv
H06.07	Pulse Monitor Scaling	Sets the output frequency of the terminal (MP) at 100%. To monitor output frequency simultaneously, set H06.06 = 102 and H06.07 = 0	0 – 32,000 Hz	1440	Adv

# Protection Parameters

The IMPULSE•G+ Mini has the ability to protect both the drive's hardware and motor by allowing various means to detect and take corrective action when a condition occurs. These include motor overload detection, torque detection, and the ability to perform a self-diagnostic check, and then resume operation after a fault is cleared.

- L1 Motor Overload
- L2 Power Loss Ride Thru
- L3 Stall Prevention
- L4 Reference Detection
- L6 Torque Detection
- L8 Hardware Protection
- L9 Automatic Reset

## Motor Overload

The IMPULSE•G+ Mini protects against motor overload with a UL-recognized, built-in electronic thermal overload function, so an external thermal overload relay is not required for single motor operation.

The electronic thermal overload function estimates motor temperature, based on inverter output current, frequency and time to protect the motor from overheating. This time is based on a "hot start" for the motor (see Figure 5-27: "Motor Protection Operation Time"). When the thermal overload fault is activated, an "OL1" trip occurs, shutting OFF the inverter output and preventing excessive overheating in the motor. As long as the inverter is powered up, it continues to calculate the motor temperature.

When operating several motors with one inverter, use the internal thermal protection from the motor in accordance with NEC 430.126 (c) or install an external thermal overload relay on each motor and disable the motor overload protection, L01.01 = "00".

Parameter Code	Name	Function	Range	Initial Value	Access Level
L01.01	Motor Overload Fault Select	Enable/disable motor overload detection.	00–03	03	Basic/Adv
	00 <i>Disabled</i>	Disables the motor thermal overload protection			
	01 <i>Standard Fan Cooled</i>	Selects a motor with limited cooling capability below rated (base) speed when running at 100% load. The OL1 function derates the motor any time it is running below base speed.			
	02 <i>Standard Blower Cooled</i>	Selects a motor capable of cooling itself over a 10:1 speed range when running at 100% load. The OL1 function derates the motor when it is running at 1/10th of its rated (base) speed or less.			
	03 <i>Vector Motor</i>	Selects a motor capable of cooling itself at any speed when running at 100% load. Includes zero speed. The OL1 function does not derate the motor at any speed.			
L01.02	Motor Overload Time Const	Time for OL1 fault when motor current is $\geq 150\%$ of the motor rated current. Hot start. See Figure 5-27.	0.1–5.0 min	1.0	Basic/Adv
L01.03	Motor Overheat Alarm Selection	Operation when the motor temperature analog input exceeds the OH3 alarm level. (1.17V) (H03.02 or 10 = 0E)	00–04	03	Adv
	00 <i>Decel to Stop (Alarm)</i>				
	01 <i>Coast to Stop (Alarm)</i>				
	02 <i>Fast Stop by B05.08 (Alarm)</i>				
	03 <i>Alarm Only (OH3 Flashes)</i>				
	04 <i>Stop by B03.03 Method (Alarm)</i>				
L01.04	Motor Overheat Fault Selection	Operation when the motor temperature analog input exceeds the OH4 fault level. (2.34V) (H03.05 or 09 = 0E)	00–03	03	Adv
	00 <i>Decel to Stop</i>				
	01 <i>Coast to Stop</i>				
	02 <i>Fast Stop by B05.08</i>				
	03 <i>Stop by B03.03 method</i>				
L01.05	Motor Temp Filter	Motor temperature analog input filter time constant	0.00–10.00sec	0.20	Adv
L01.13	Overload Operation Selection	Determines whether or not to hold the Electrothermal value when power is interrupted	00–01	01	Adv
	00 <i>Disable</i>				
	00 <i>Enable</i>				

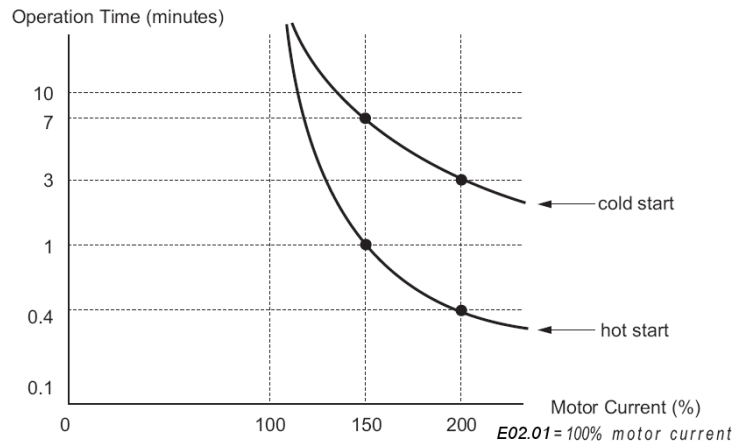

**Figure 5-27: Motor Protection Operation Time**

## Power Loss Ride Thru

Parameter Code	Name	Function	Range	Initial Value	Access Level
L02.01	Power-Loss Selection	Enables/disables the Power Loss Ride Thru function	00–02	00	Adv
	00 Disable	Disabled			
	01 Enable	Drive will restart if power returns within L02.02			
	02 CPU Power Active	Drive will restart if power returns before control supply shutdown			
L02.02	Power-Loss Ride Thru Time	Power Loss Ride Thru time	0.0–25.5 sec	Varies	Adv
L02.03	Power-Loss BaseBlock Time	Output turn on delay after power resumes	0.1–5.0 sec	Varies	Adv
L02.04	Power-Loss V/F Ramp Time	Voltage recovery time after speed search is complete	0.0–5.0 sec	Varies	Adv
L02.05	PUV Detection Level	Under voltage fault detection level	150–210 VDC 300–420 VDC	190/380	Adv
L02.07	Power-Loss Ride Thru Accel	Acceleration time after a Power Loss Ride Thru	0.0–25.5	0.0	Adv

## Stall Prevention



### CAUTION

This function automatically adjusts the output frequency, acceleration and/or deceleration rates in order to continue operation without tripping or “stalling” the inverter.

Parameter Code	Name	Function	Range	Initial Value	Access Level
L03.01	Stall Prevention Accel Select	Enable/disable stall prevention during acceleration.	00–02	01	Basic/Adv
	00 <i>Disable</i>	See Table 5-8			
	01 <i>General Purpose</i>	See Table 5-8			
	02 <i>Intelligent</i>	See Table 5-8			

**Table 5-8: Stall Prevention Accel Selection**

Setting	Description
00 Disable	Stall prevention/current limit during acceleration is disabled. The inverter increases the output frequency at the set acceleration rate. If the acceleration rate is too fast for the load condition, the inverter may trip on overcurrent (OC) or overload (OL).
01 General Purpose	Stall prevention/current limit during acceleration is enabled (factory default). The acceleration rate is automatically extended according to motor current to prevent stalling during acceleration. The acceleration time may be longer than the set value (B05.01).
02 Intelligent	Stall prevention/current limit during acceleration is enabled with an intelligent acceleration mode. By monitoring motor current, the acceleration is the shortest amount of time, regardless of the set acceleration time.

Parameter Code	Name	Function	Range	Initial Value	Access Level
L03.02	Stall Prevention Accel Level	Stall prevention level during acceleration.	0–150%	150	Basic/Adv

The stall prevention/current limit level during acceleration is set as a percentage of inverter rated current. Setting L03.01 = 00 disables current limit during acceleration. During acceleration, if the output current exceeds this current limit level (L03.02), acceleration stops and frequency is maintained. When the output current decreases below this current level (L03.02), acceleration restarts. See below, Figure 5-28.

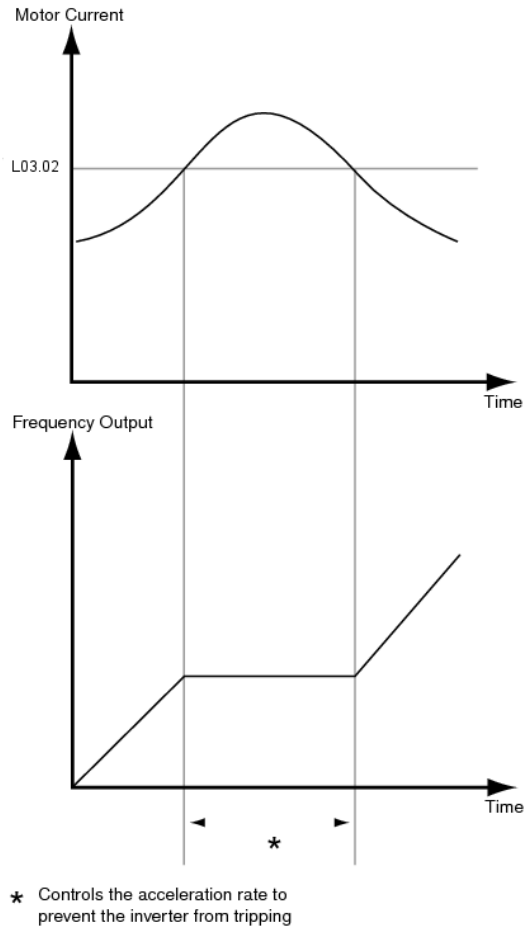
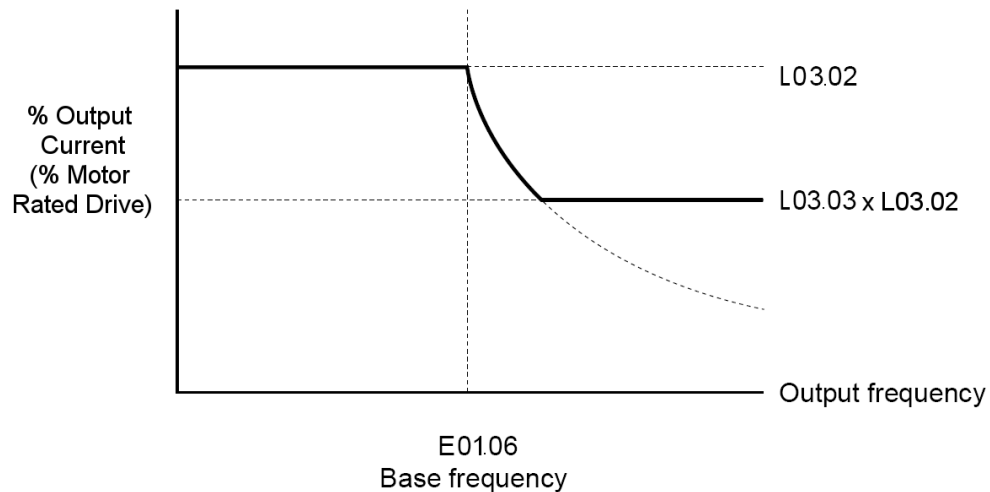

**Figure 5-28: Stall Prevention/Current Limit During Acceleration**

Parameter Code	Name	Function	Range	Initial Value	Access Level
L03.03	Stall Prevention Constant HP Limit	Stall prevention limit	0–100%	50	Basic/Adv

When a motor is used above rated speed (E01.06), the output characteristics change from constant torque to constant HP (See Figure 5-29). During acceleration above rated speed, the stall prevention current limit level is automatically reduced for smoother acceleration. The parameters (L03.02 and L03.03) limit the stall prevention current limit level in this region. The current limit during acceleration is changed according to the following equation:

$$\boxed{\text{Current Limit Level During Accel in Constant Output Area}} = \boxed{\text{Current Limit Level During Acceleration (L03.02)}} \times \frac{\text{Max Voltage Output Frequency (E01.06)}}{\text{Output Frequency}}$$



**Figure 5-29: Stall Prevention Constant HP Limit**



**CAUTION**

This function automatically adjusts the output frequency, acceleration and/or deceleration rates in order to continue operation without tripping or “stalling” the inverter.

<b>Parameter Code</b>	<b>Name</b>	<b>Function</b>	<b>Range</b>	<b>Initial Value</b>	<b>Access Level</b>
L03.05	Stall Prevention Run Select	Enable/Disable stall prevention during running	00–02	01	Basic/Adv
	00 <i>Disable</i>	See Table 5-9			
	01 <i>Decel Time 1</i>	See Table 5-9			
	02 <i>Decel Time 2</i>	See Table 5-9			

Sets a function to prevent stalling during an overload condition while running at constant speed.

***Table 5-9: Stall Prevention Run Selection***

<b>Setting</b>	<b>Description</b>
00 <i>Disable</i>	Stall prevention/current limit during running is disabled.
01 <i>Decel Time 1</i>	Stall prevention/current limit during running is enabled (factory default). When the inverter output current exceeds the current limit level (L03.06) for more than 100ms during speed agree, the output frequency is decreased according to deceleration time 1 (B05.02). This can help prevent stalling. When the load condition is stabilized, the inverter accelerates to the previous frequency.
02 <i>Decel Time 2</i>	Stall prevention/current limit running is enabled as in setting “01”, however the output frequency is decreased according to deceleration time 2 (B05.04).



Parameter Code	Name	Function	Range	Initial Value	Access Level
L03.06	Stall Prevention Run Level	Stall prevention level during run.	30–150%	150	Basic/Adv

The stall prevention/current limit level during running is set as a percentage of inverter rated current. A setting of L03.05 = 00 disables current limit during running. During speed agree, if the output current exceeds this current limit level (*L03.06*) during running, deceleration starts. When the output current decreases below this current limit level (*L03.06*), acceleration starts, up to the set frequency. See Figure 5-30 below.

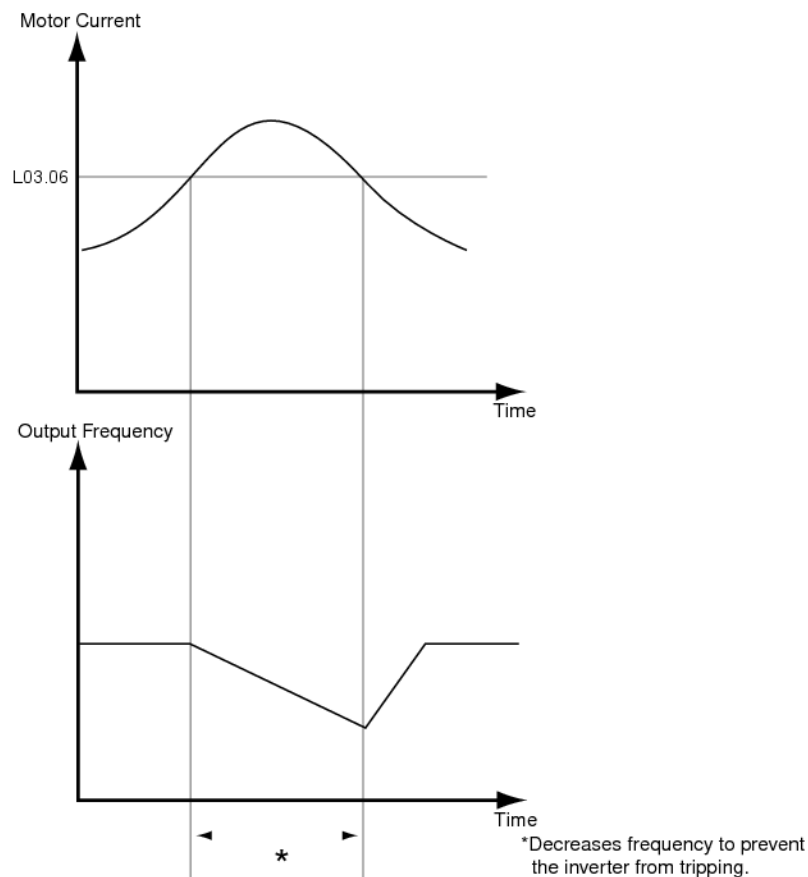

**Figure 5-30: Stall Prevention/Current Limit During Running**

Parameter Code	Name	Function	Range	Initial Value	Access Level
L03.17	Overvoltage Suppression and Stall Prevention	Sets the desired value for the DC bus voltage during overvoltage suppression and Stall Prevention during deceleration. Enabled only when L03.04 = 02 or L03.11 = 01.	150–400 VDC	370	Adv
L03.23	Automatic Reduction Selection for Stall Prevention during Run	Automatic Reduction Selection for Stall Prevention during Run  <i>00 Sets the Stall Prevention level throughout the entire frequency range to the value in parameter L03.06</i>  <i>01 Automatically lowers the Stall Prevention level in the constant output range. The lower limit value is 40% of L03.06</i>	00, 01	00	Adv
L03.24	Motor Acceleration Time for Inertia Calculations	Sets the time needed to accelerate the uncoupled motor at rated torque from stop to the maximum frequency. Setting the drive capacity to parameter O02.04 or changing E02.11 will automatically set this parameter for a 4-pole motor.	0.001–10.000	** Depends on O02.04	Adv
L03.25	Load Inertia Ratio	Sets the ratio between the connected machinery and the motor	0.0–1000.0	1.0	Adv

## Reference Detection

The IMPULSE•G+ Mini utilizes three different functions for detecting output frequency:

- *When frequency agree is enabled using the multi-function contact outputs (H02.XX = “002” or “013”), the contact closes whenever the output frequency “agrees” with the frequency reference, plus or minus the speed agree detection width.*
- *When desired frequency agree is enabled using the multi-function contact outputs (H02.XX = “003” or “014”), the contact closes whenever the output frequency “agrees” with the speed agree detection level, plus or minus the speed agree detection width.*
- *When frequency detection is enabled using the multi-function contact outputs (H02.XX = “004,” “005,” “015,” “016,” “104,” “105,” “115,” or “116”), the contact opens or closes whenever the output frequency is less than or more than the speed agree detection level, depending on which detection is selected.*

Parameter Code	Name	Function	Range	Initial Value	Access Level
L04.01	Speed Agree Level	Speed Agree Level ±	0.0–150.0 Hz	0.0	Basic/Adv

Sets the detection level for the desired frequency agree 1 and frequency detection 1 and 2 functions. The set detection level is effective during both FWD and REV operation.

Parameter Code	Name	Function	Range	Initial Value	Access Level
L04.02	Speed Agree Width	Speed Agree Width ±	0.0–20.0 Hz	2.0	Adv

Sets the detection width for frequency and desired frequency agree 1 and frequency detection 1 and 2 functions.

Parameter Code	Name	Function	Range	Initial Value	Access Level
L04.03	Speed Agree Lvl ±	Speed Agree Level ±	-150.0–150.0 Hz	0.0	Adv

Sets the detection level for the desired frequency agree 2 and frequency detection 3 and 4 functions. The set detection level is effective during either FWD or REV operation, depending on the set detection level (positive value for FWD operation, negative value for REV operation).

Parameter Code	Name	Function	Range	Initial Value	Access Level
L04.04	Speed Agree Width ±	Speed Agree Width ±	0.0–20.0 Hz	2.0	Adv

Sets the detection width for frequency and desired frequency agree 2 and frequency detection 3 and 4 functions.

<b>Parameter Code</b>	<b>Name</b>	<b>Function</b>	<b>Range</b>	<b>Initial Value</b>	<b>Access Level</b>
L04.07	Speed Agree Detection	Sets the detection level during baseblock	00, 01	00	Adv
	<i>00 No detection during baseblock</i>				
	<i>01 Detection always enabled</i>				

## Torque Detection

The overtorque detection circuit activates when the motor load causes the motor current to exceed the overtorque detection level (L06.02). When an overtorque condition is detected, alarm signals will be shown on the keypad as well, and can be sent to a multi-function output. To output an overtorque detection signal, select torque detection 1 at either of the multi-function contact outputs (H02.xx = “00B,” “017,” “10B,” or “117”).

Parameter Code	Name	Function	Range	Initial Value	Access Level
L06.01	Torque Detect 1 Select	Activates overtorque/undertorque detection and selects whether detection generates an alarm or a fault	00–08	00	Basic/Adv
	00 <i>Disable</i>				Basic
	01 <i>Overtorque At Speed Agree (Alarm)</i>				Basic
	02 <i>Overtorque At Run (Alarm)</i>				Basic
	03 <i>Overtorque At Speed Agree (Fault)</i>				Basic
	04 <i>Overtorque At Run (Fault)</i>				Basic
	05 <i>UT At Speed Agree (Alarm)</i>				Adv
	06 <i>UT At Run (Alarm)</i>				Adv
	07 <i>UT At Speed Agree (Fault)</i>				Adv
	08 <i>UT At Run (Fault)</i>				Adv

**Table 5-10: Torque Detection 1 Selection Definition**

Setting	Description
00	Torque detection is disabled ( <i>factory default</i> ).
01	Overtorque detection is enabled whenever at the speed agree level (when inverter is not accelerating or decelerating). Continue running after detection (OT1 alarm).
02	Overtorque detection is enabled always. Continue running after detection (OT1 alarm).
03	Overtorque detection is enabled whenever at the speed agree level. Coast to a stop after detection (OT1 fault).
04	Overtorque detection is enabled always. Coast to a stop after detection (OT1 fault).
05	Undertorque detection is enabled whenever at the speed agree level (when inverter is not accelerating or decelerating). Continue running after detection (UT1 alarm).
06	Undertorque detection is enabled always. Continuing running after detection (UT1 alarm).
07	Undertorque detection is enabled whenever at the speed agree level. Coast to a stop after detection (UT1 fault).
08	Undertorque detection is enabled always. Coast to stop after detection (UT1 fault)

- NOTE:**
- To detect overtorque during acceleration or deceleration, set to “02” or “04” / “06” or “08”.
  - To continue operation after overtorque detection, set to “01” or “02” / “05” or “06”. During detection, the digital operator displays an “OT1/UT1” alarm (blinking).
  - To stop the inverter after an overtorque detection fault, set to “03” or “04” / “07” or “08”. During detection, the digital operator displays an “OT1/UT1” fault.

Parameter Code	Name	Function	Range	Initial Value	Access Level
L06.02	Torque Detection 1 Level	Sets the overtorque detection as a percentage of inverter rated current, during V/f control, and motor rated torque during vector control.	0–300%	150	Basic/Adv
L06.03	Torque Detection 1 Time	The overtorque detection delay time inserts a delay, between the time motor current (or torque) exceeds the overtorque level (L06.02) and when the overtorque detection function is enabled. The digital operator then displays “OT1”.	0.0–10.0 sec	0.1	Basic/Adv
L06.04	Torque Detection 2 Select	Activates overtorque/undertorque detection, and selects whether detection generates an alarm or a fault.	00–08	00	Adv
	00 Disable				Adv
	01 Overtorque At Speed Agree (Alarm)				Adv
	02 Overtorque At Run (Alarm)				Adv
	03 Overtorque At Speed Agree (Fault)				Adv
	04 Overtorque At Run (Fault)				Adv
	05 UT At Speed Agree (Alarm)				Adv
	06 UT At Run (Alarm)				Adv
	07 UT At Speed Agree (Fault)				Adv
	08 UT At Run (Fault)				Adv

**Table 5-11: Torque Detection 1 Selection Definition**

Setting	Description
00	Torque detection is disabled ( <i>factory default</i> ).
01	Overtorque detection is enabled whenever at the speed agree level (when inverter is not accelerating or decelerating). Continue running after detection (OT1 alarm).
02	Overtorque detection is enabled always. Continue running after detection (OT1 alarm).
03	Overtorque detection is enabled whenever at the speed agree level. Coast to a stop after detection (OT1 fault).
04	Overtorque detection is enabled always. Coast to a stop after detection (OT1 fault).
05	Undertorque detection is enabled whenever at the speed agree level (when inverter is not accelerating or decelerating). Continue running after detection (UT1 alarm).
06	Undertorque detection is enabled always. Continuing running after detection (UT1 alarm).
07	Undertorque detection is enabled whenever at the speed agree level. Coast to a stop after detection (UT1 fault).
08	Undertorque detection is enabled always. Coast to stop after detection (UT1 fault)

Overtorque detection 2 functions the same as overtorque/undertorque detection 1 (*L06.01*), except that “OT2/UT2” is displayed on the digital operator instead. This function is used when two types of detection are output to the multi-function output terminals.

Parameter Code	Name	Function	Range	Initial Value	Access Level
L06.05	Torque Detection 2 Level	Torque Detection 2 Level	0–300%	150	Adv
L06.06	Torque Detection 2 Time	Torque Detection 2 Time	0.0–10.0 sec	0.1	Adv
L06.08	Mechanical Weakening Detection Selection	Determines the action to take during and after detection	00–08	00	Adv
	00 <i>Disabled</i>				
	01 <i>Speed (signed) &gt; L06.09; Continue Running (Alarm)</i>				
	02 <i>Speed (unsigned) &gt; L06.09; Continue Running (Alarm)</i>				
	03 <i>Speed (signed) &gt; L06.09; Stop (Protection)</i>				
	04 <i>Speed (unsigned) &gt; L06.09; Stop (Protection)</i>				
	05 <i>Speed (signed) &lt; L06.09; Continue Running (Alarm)</i>				
	06 <i>Speed (unsigned) &lt; L06.09; Continue Running (Alarm)</i>				
	07 <i>Speed (signed) &lt; L06.09; Stop (Protection)</i>				
	08 <i>Speed (unsigned) &lt; L06.09; Stop (Protection)</i>				
L06.09	Mechanical Weakening Detection Speed Level	Sets the speed for Load Weakening Detection	-110.0–100.0%	100.0	Adv
L06.10	Mechanical Weakening Detection Time	Sets the time required for Mechanical Weakening to be detected before triggering parameter L06.08.	0.0–10.0 sec	0.1	Adv
L06.11	Mechanical Weakening Detection Start Time	Mechanical Weakening Detection is triggered when the cumulative operation time exceeds U04.01.	00000–65535	00000	Adv

## Hardware Protection

The IMPULSE•G+ Mini comes equipped with a number of built-in functions designed to protect the inverter and its components from damage.

Parameter Code	Name	Function	Range	Initial Value	Access Level
L08.02	OH Pre-Alarm Level	Sets the heatsink temperature level for protection against overheat (OH).  Note: The inverter measures heatsink temperature by a negative temperature coefficient thermistor.	50–130°C	95°	Adv
L08.03	OH Pre-Alarm Selection	Selects the stopping method when heatsink overheat is detected.	00–05	05	Adv
	00 <i>Decel to Stop</i>	<i>(Decel to stop using B05.02)</i>			
	01 <i>Coast to Stop</i>	<i>(Immediate stop)</i>			
	02 <i>Fast-Stop</i>	<i>(Decel to stop using B05.08)</i>			
	03 <i>Use B03.03 Method</i>	<i>Uses programmed B03.03 Method</i>			
	04 <i>Alarm Only</i>	<i>(Operation continues and “OH Heatsink Overtemp” is displayed on keypad)</i>			
	05 <i>Derated Operation</i>	<i>Operation continues, but derates the frequency based on L08.19</i>			
L08.05	Input Phase Loss Selection	Input phase loss detection  00 <i>Disabled</i> 01 <i>Enabled</i>	00, 01	01	Adv
L08.06	Input Phase Detection Level	Input phase loss detection level  Note: Increasing L08.06 level from default may cause DB Bus Capacitor Failure	0.0–50.0%	5.0	Adv
L08.07	Output Phase Loss Selection	Output phase loss detection  00 <i>Disabled</i> 01 <i>1PH Loss Det</i> 02 <i>2/3PH Loss Det</i>	00–02	01	Adv
L08.08	Output Phase Loss Detection Level	Output Phase Loss Detection Level	0.0–20.0%	5.0	Adv
L08.09	Ground Fault Detect	Enables/disables ground fault detection  00 <i>Disabled</i> 01 <i>Enabled</i>	00, 01	01*	Basic/Adv
L08.10	Fan Operation Selection	Cooling fan operation select  00 <i>Fan On-Run Mode</i> 01 <i>Fan Always On</i>	00, 01	00	Adv
L08.11	Fan Off-Delay Time	Fan delay time	0–300 sec	60	Adv
L08.12	Ambient Temp	Adjusts Overload (OL2) Protection for high ambients	-10–50°C	40°	Adv
L08.15	OL2 Sel @ Low Spd	Enables/disables OL when output frequency $\leq$ 6 Hz  00 <i>Disabled</i> 01 <i>Enabled</i>	00, 01	01	Adv

\* Value depends on drive model



<b>Parameter Code</b>	<b>Name</b>	<b>Function</b>	<b>Range</b>	<b>Initial Value</b>	<b>Access Level</b>
L08.18	Soft CLA Sel	Enables/disables the software current limit function. Limits output frequency when current exceeds 110% of rated.	00–01	01	Adv
	<i>00 Disabled</i>				
	<i>01 Enabled</i>				
L08.19	Overheat Pre-Alarm Frequency Reduction Rate		0.1–0.9%	0.8	Adv
L08.35	Mounting Selection	Mounting selection	00–03	00	Adv
	<i>00 Disabled (Standard Installation)</i>				
	<i>01 Side-by-Side</i>				
	<i>02 NEMA 1 Standard</i>				
	<i>03 Finless</i>				
L08.41	High Current Alarm Selection	High current alarm selection	00–01	00	Adv
	<i>00 Disable</i>				
	<i>01 Enable</i>				

## Automatic Reset

When a fault occurs during operation, the IMPULSE•G+ Mini can be programmed to automatically reset the fault and restart operation.

Parameter Code	Name	Function	Range	Initial Value	Access Level
L09.01	Auto Reset Select	Activates the fault auto-reset function.	00, 01	01	Basic/Adv
	<i>00 Disabled</i>				
	<i>01 Enabled</i>				
L09.02	Auto Reset Attempts	Sets the number of reset attempts. Reset attempt counter is returned to zero if no faults occur within a ten minute period.	00–10	03	Basic/Adv
L09.03	Auto Reset Time	Sets the reset starting time	0.5–180.0 sec	0.5	Basic/Adv
L09.04*	Auto Reset Flt Sel 1	Reset Fault Select 1.	0000–FFFF	0001	Basic/Adv
L09.05*	Auto Reset Flt Sel 2	Reset Fault Select 2.	0000–FFFF	E000	Basic/Adv
L09.06	Output Contact (MC-MB-MA) Select	Fault contact operation during reset attempts	00, 01	01	Basic/Adv
	<i>00 No Fault Relay</i>				
	<i>01 Fault Relay active</i>				

\* To program constant L09.04 and L09.05, refer to the example on the following page and follow steps 1 through 4:

1. Assign a “1” to each fault code that you wish to enable the auto reset.
2. Assign a “0” to each fault code that you wish to disable the auto reset.
3. Convert all digits (1 to 4) from binary to hex.
4. Program L09.04 and L09.05 by entering the hex number obtained from step 3.

**Example:**

Enable auto-reset for UV2 and CE faults.

**Table 5-12: Auto Reset Table (default)**

	Digit 4	Digit 3	Digit 2	Digit 1
HEX	0	0	0	1
Binary	0 0 0 0	0 0 0 0	0 0 0 0	0 0 0 1
L09.04	E - - - F - - - 0 - - -	L P U - F F T - 1 - -	O S O G H C V F 1	O U U U C V V V 3 2 1
HEX	E	0	0	0
Binary	1 1 1 0	0 0 0 0	0 0 0 0	0 0 0 0
L09.05	B B C F E E O B 1 2 F L	O O O O L L T T 1 2 1 2	C C - E E A - F L - 7 L	E E E E F F F F 6 5 4 3

**Table 5-13: Auto Reset Table with UV2 and CE Fault (modified)**

	Digit 4	Digit 3	Digit 2	Digit 1
HEX	0	0	0	3
Binary	0 0 0 0	0 0 0 0	0 0 0 0	0 0 1 1
L09.04	E - - - F - - - 0 - - -	L P U - F F T - 1 - -	O S O G H C V F 1	O U U U C V V V 3 2 1
HEX	E	0	8	0
Binary	1 1 1 0	0 0 0 0	1 0 0 0	0 0 0 0
L09.05	B B C F E E O B 1 2 F L	O O O O L L T T 1 2 1 2	C C - E E A - F L - 7 L	E E E E F F F F 6 5 4 3

1. Place a “1” above UV2 and CE faults.
2. Convert binary to hexadecimal using Table 5-16 for each digit.
3. Program L09.04 to 0003 to enable UV2 and UV1 from Table 5-12.
4. Program L09.05 to E080 to enable BE1, BE2, CoF, and CE from Table 5-16.

**Table 5-14: UV2 Example**

<b>L09.04</b>	<b>Binary</b>	<b>HEX</b>
Digit 4	0000	0
Digit 3	0000	0
Digit 2	0000	0
Digit 1	0011	3

**Table 5-15: CE Example**

<b>L09.05</b>	<b>Binary</b>	<b>HEX</b>
Digit 4	1110	E
Digit 3	0000	0
Digit 2	1000	8
Digit 1	0000	0

**Table 5-16: Binary to Hexadecimal Conversion**

<b>Binary Number</b>	<b>Hexadecimal Number</b>
0000	0
0001	1
0010	2
0011	3
0100	4
0101	5
0110	6
0111	7
1000	8
1001	9
1010	A
1011	B
1100	C
1101	D
1110	E
1111	F

# Motor Tuning

- N2 Automatic Frequency Regulator Tuning (OLV Only)
- N6 Online Tuning

## Automatic Frequency Regulator Tuning (OLV Only)

The Automatic Frequency Regulator (AFR) is used to achieve stability when a load is suddenly applied or removed by calculating changes in the torque current feedback, and adjusting the output frequency accordingly.

If the system is hunting, increase the OLV Stabilization Level (N02.05) by one until the load stabilizes. Both D03.02 and N02.01 will be incremented or decremented accordingly. See Table 5-17: OLV Stabilization Level.

Parameter Code	Name	Function	Range	Initial Value	Access Level
N02.01	Automatic Frequency Regulator (AFR) Tuning	Automatic Frequency Regulator (AFR) Tuning	0.00–10.00	1.00	Adv
N02.02	AFR Detection Time	AFR Detection Time	0–2000ms	150	Adv
N02.03	AFR Time Constant	AFR Time Constant	0–2000ms	750	Adv
N02.04	AFR Limit	AFR Limit	0.0–60.0 Hz	5.0	Adv
N02.05	OLV Stabilization Level	Sets the stabilization for OLV control	00–11, FF	08	Adv

**Table 5-17: OLV Stabilization Table**

Control Method (A01.02) Setting	OLV Stabilization Level (N02.05) Setting (Hex)	Torq. Comp Time (D03.02) Set Value	AFR Time (N02.02) Set Value	Independent setting of D03.02 & N02.02
2 (OLV)	00 (default)	20	50	No
	01	25	63	No
	02	30	75	No
	03	35	88	No
	04	40	100	No
	05	45	113	No
	06	50	125	No
	07	55	138	No
	08	60	150	No
	09	65	163	No
	0A	70	175	No
	0B	75	188	No
	0C	80	200	No
	0D	85	213	No
	0E	90	225	No
	0F	95	238	No
	10	100	250	No
11	105	263	No	
FF	Note 1	Note 1	Yes	

*NOTE 1:* If N02.05 is changed to an FF(hex) using the digital operator, the values that were in D03.02 & N02.02 will be retained. Example: N02.05 = 08(hex), which sets D03.02 = 60 and N02.02 = 150. When N02.05 is then changed to FF(hex) the values remain unchanged, D03.02 = 60 & N02.02 = 150.

When N02.05 = FF, use the following equation to determine the new N02.02 value:

$$N02.02_{(new)} = \left( \frac{D03.02_{(new)}}{D03.02_{(default)}} \right) \times N02.02_{(default)}$$

*NOTE:* If the motor is hunting, increase the value of N02.05 per the table to stabilize the load.



**CAUTION**

*Increasing the value of N02.05 too high may result in the motor not developing enough torque to lift the load.*

## Online Tuning

<b>Parameter Code</b>	<b>Name</b>	<b>Function</b>	<b>Range</b>	<b>Initial Value</b>	<b>Level Access</b>
N06.01	Line-to-Line Motor Tuning Selection	Line-to-Line Motor Tuning	00–01	01	Adv
		<i>00 Disabled</i>			
		<i>01 Enabled</i>			

# Operator Parameters

The keypad parameters give the ability to show a variety of information such as frequency reference, motor current, input and output terminal status, along with fault trace information. Information displayed can be customized to meet your crane and hoist application. Below is a list of parameters covered in this section.

- O1 Monitor Selection
- O2 Keypad Key Selection
- O3 Clear History
- U1 Monitor
- U2 Fault Trace
- U3 Fault History
- U4 Maintenance
- U6 Motor Control Monitor

## Monitor Selection

The top level in the operator mode allows the viewing of four monitor variables. They are Fref, Fout, Iout, and User-Selected monitor. This user-selected monitor can be selected from the following table.

<b>Parameter Code</b>	<b>Name</b>	<b>Function</b>	<b>Range</b>	<b>Initial Value</b>	<b>Access Level</b>
001.01	User Monitor Selection	Assigns one of the following monitor parameters to be displayed upon power-up. For example, set 001.01 = 403 to display U04.03.  <i>104 Control Method</i> <i>105 Motor Speed - OLV ONLY</i> <i>106 Output Voltage</i> <i>107 DC Bus Voltage</i> <i>108 Output Power</i> <i>109 Torque Reference - OLV ONLY</i> <i>110 Input Terminal Status</i> <i>111 Output Terminal Status</i> <i>112 Operation Status</i> <i>113 Elapsed Time</i> <i>114 FLASH ID</i> <i>115 Terminal A1 level</i> <i>116 Terminal A2 level</i> <i>120 Output Frequency After Soft Start</i> <i>128 CPU ID</i> <i>134 OPE Detected</i> <i>139 Memobus Comm Error Code</i> <i>152 Maintenance Timer</i> <i>154 Input Pulse Monitor</i> <i>162 Not Used</i>	104–638	106	Adv



<b>Parameter Code</b>	<b>Name</b>	<b>Function</b>	<b>Range</b>	<b>Initial Value</b>	<b>Access Level</b>
		164 LC Zone			
		165 LC Margin			
		401 Cumulative Operation Time			
		403 Cooling Fan Operation Time			
		404 Cooling Fan Maintenance			
		405 Capacitor Maintenance			
		406 Soft Charge Bypass Relay Maintenance			
		407 IGBT Maintenance			
		408 Heatsink Temperature			
		410 kWh; Lower 4 Digits			
		411 kWh; Upper 5 Digits			
		412 CPU Resources Used			
		413 Peak Hold Current			
		414 Peak Hold Output Frequency			
		416 Motor Overload (oL1) Detection Level			
		417 Drive Overload (oL2) Detection Level			
		418 Frequency Reference Source Selection			
		419 Frequency Reference Memobus			
		420 Output Frequency Reference (decimal)			
		421 Run Command Selection Results			
		422 Memobus Communication Reference			
		423 Not Used			
		601 Motor Secondary Current (Iq)			
		602 Motor Excitation Current (Id) - OLV ONLY			
		605 Output Voltage Reference (Vq) - OLV ONLY			
		606 Output Voltage Reference (Vd) - OLV ONLY			
		607 ACR (q) Output - OLV ONLY			
		608 ACR (d) Output - OLV ONLY			
		620 Frequency Reference Bias (Up/Down 2)			
		621 Offset Frequency			
		636 Not Used			
		637 Not Used			
		638 Not Used			

<b>Parameter Code</b>	<b>Name</b>	<b>Function</b>	<b>Range</b>	<b>Initial Value</b>	<b>Access Level</b>
001.02	Power-On Monitor	Selects the monitor to be displayed on the digital operator immediately after the power supply is turned on. <i>01 Frequency Reference (U01.01)</i> <i>02 Forward/Reverse</i> <i>03 Output Frequency (U01.02)</i> <i>04 Output Current (U01.03)</i> <i>05 User Monitor (O01.01)</i>	01–05	03	Adv
001.03	Display Scaling	Units for parameters and monitor related to frequency reference and output frequency can be scaled as shown below <i>00 0.01 Hz</i> <i>01 0.01%</i> <i>02 r/min</i> <i>03 User-set</i>	00–03	00	Adv
001.10	User-set Display Maximum Units	Sets maximum when operating at maximum output frequency	00000–60000	06000	Adv
001.11	User-set Display Decimal	Sets user display decimal point <i>00 No Decimal Point</i> <i>01 01.</i> <i>02 0.01</i> <i>03 0.001</i>	00–03	02	Adv

## Keypad Key Selection

<b>Parameter Code</b>	<b>Name</b>	<b>Function</b>	<b>Range</b>	<b>Initial Value</b>	<b>Access Level</b>
002.01	Local/Remote Key	Sets Local/Remote Key Operation <i>00 Disable</i> <i>01 Enable</i>	00–01	00	Adv
002.02	Stop Key Operation	Sets Stop key Operation <i>00 Coast to Stop</i> <i>01 Decel to Stop</i> <i>02 Use B03.03 Stopping Method</i>	00–02	00	Adv
002.03	User Defaults	Sets/Clears User Defaults <i>00 No Change</i> <i>01 Set Defaults</i> <i>02 Clear All</i>	00–02	00	Adv
002.04	kVA Selection	Determines the model number of the drive, which is based on the kVA rating. The following in this column are Magnetek model numbers. *Initial value determined by Inverter model.  <i>60 2A0001</i> Not used. <i>61 2A0002</i> 2001-G+M <i>62 2A0004</i> 2003-G+M <i>63 2A0006</i> 2005-G+M <i>64 --</i> Not used	60–90	*	Basic/ Adv

Parameter Code	Name	Function	Range	Initial Value	Access Level
	65 2A0010	2008-G+M			
	66 2A0012	2011-G+M			
	67 2A0018	Not used			
	68 2A0020	2017-G+M			
	69 --	Not used			
	6A 2A0030	2025-G+M			
	6B 2A0040	2033-G+M			
	6C --	Not used			
	6D 2A0056	2047-G+M			
	6E 2A0069	2060-G+M			
	91 4A0001	4001-G+M			
	92 4A0002	4002-G+M			
	93 4A0004	4003-G+M			
	94 4A0005	4004-G+M			
	95 4A0007	4005-G+MF (OEM only)			
	96 4A0009	4007-G+MF (OEM only)			
	97 4A0011	4009-G+M			
	98 --	Not used			
	99 4A0018	4014-G+M			
	9A 4A0023	4018-G+M			
	9B --	Not used			
	9C 4A0031	4024-G+M			
	9D 4A0038	4031-G+M			
002.05	Operator M.O.P.	Selects whether the ENTER key is used when the frequency reference is set by the digital operator. The digital operator can simulate a motor operated potentiometer (M.O.P.) by setting this parameter.	00, 01	00	Adv
	00 Disabled	ENTER Key Required			
	01 Enabled	ENTER Key Not Required			
				<i>Note: This feature cannot be used in conjunction with infinitely variable speed control.</i>	
002.07	Motor Direction at Power-Up	Sets direction of motor at power-up.	00, 01	00	Adv
		00 Forward			
		01 Reverse			

## Clear History

Parameter Code	Name	Function	Range	Initial Value	Access Level
003.01	Elapsed Time Setting	--	0000–9999hr	0000	Adv
003.02	Elapsed Time Selection	Selects how the Elapsed Time is accumulated	00, 01	01	Adv
		00 Power On Time			
		01 Running Time			
003.03	Fan On Time	--	0000–9999hr	0000	Adv
003.05	Capacitor Maintenance Time	--	000–150%	000	Adv

<b>Parameter Code</b>	<b>Name</b>	<b>Function</b>	<b>Range</b>	<b>Initial Value</b>	<b>Access Level</b>
O03.07	Inrush Preventative Maintenance Relay Setting	--	000–150%	000	Adv
O03.09	IGBT Maintenance Setting	--	000–150%	000	Adv
O03.11	Fault Trace Clear	Clears Fault History <i>00 Not Cleared</i> <i>01 Clear U2/U3</i>	00, 01	00	Adv
O03.12	kWh Monitor Initial Value Selection	Sets kWh Monitor Initial Value <i>00 Save</i> <i>01 Reset</i>	00, 01	00	Adv
O03.14	Clear Count History	Clears count history <i>00 Not Clear</i> <i>01 Clear AC Count</i> <i>02 Clear OL/LC Count</i> <i>03 Clear Both Counts</i>	00–03	00	Adv

# Monitor Parameters

## Monitor

Parameter Code	Name	Function	Units	Access Level
U01.01	Frequency Reference	Frequency Reference	Hz	Basic/Adv
U01.02	Output Frequency	Inverter Output Frequency	Hz	Basic/Adv
U01.03	Output Current	Inverter Output Current	A	Basic/Adv
U01.04	Control Method	Displays the value of A01.02	--	Basic/Adv
U01.05	Motor Speed	Motor Speed (OLV only)	Hz	Adv
U01.06	Output Voltage	Inverter Output Voltage (Reference)	V	Basic/Adv
U01.07	DC Bus Voltage	DC Bus Voltage (Measured)	V	Basic/Adv
U01.08	Output Power	Inverter Output Power (Calculated)	HP	Basic/Adv
U01.09	Motor Torque	Motor Torque (OLV only)	%	Adv
U01.10	Input Terminal Status	Input Terminal Status	--	Basic/Adv

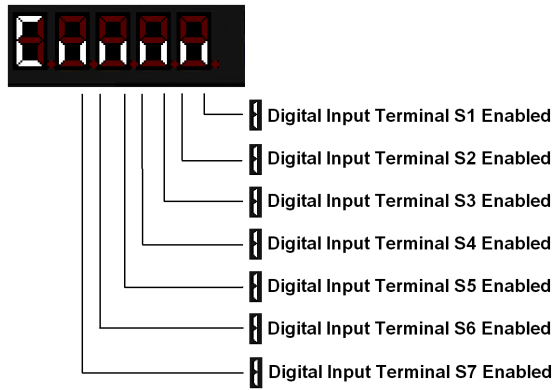

U01.11	Output Terminal Status	Output Terminal Status	--	Basic/Adv
--------	------------------------	------------------------	----	-----------

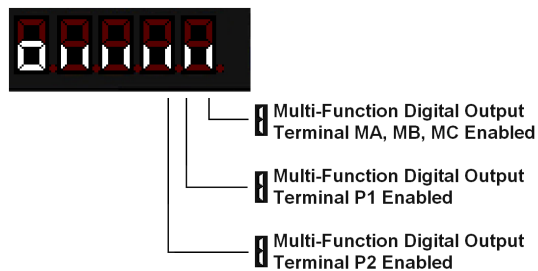

Parameter Code	Name	Function	Units	Access Level
U01.12	Inverter Control Status	Operation Status	--	Basic/Adv

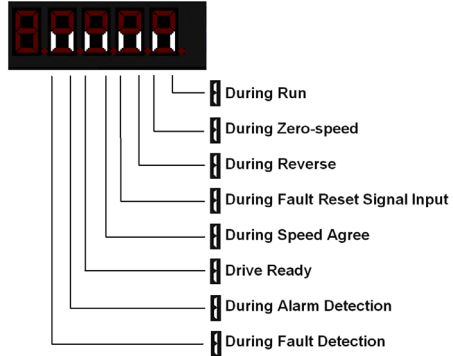

U01.13	Elapsed Time	Cummulative operation time at drive. Defined by O03.02.	hours	Basic/Adv
U01.14	Flash ID	Flash ROM software ID number	--	Basic/Adv
U01.15	Terminal A1 Level	External Terminal input level	V	Basic/Adv
U01.16	Terminal A2 Level	External Terminal input level	V/mA	Basic/Adv
U01.20	Output Frequency after Soft Start	---	Hz	Adv
U01.28	Software CPU	---	--	Adv
U01.34	OPE Detection Parameter	Parameter OPE detected	const #	Basic/Adv
U01.39	Memobus Communication Error	Displays content of MEMOBUS error	--	Adv

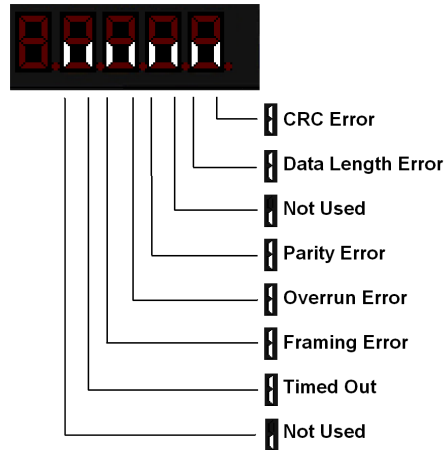

U01.52	Maintenance Timer		hr	Adv
U01.54	Pulse Monitor	Displays the pulse train input RP frequency	--	Adv
U01.64	LC Zone	Displays the LC Zone the drive is currently running in. If an LC Fault occurs, the value displayed will be which LC Zone the LC Fault occurred.	--	Adv
U01.65	LC Margin	Displays how close the current/torque levels are to the target value for each of the LC Zones. Values less than zero will cause an LC Detection and/or LC Fault to occur. If the LC Fault occurs, the value displayed will be the amount the level was below the LC Zone setting.	%	Adv

## ***Fault Trace***

<b>Parameter</b>			<b>Access</b>	
<b>Code</b>	<b>Name</b>	<b>Function</b>	<b>Units</b>	
			<b>Level</b>	
U02.01	Current Fault	Displays the most recent fault detected before being reset	--	Basic/Adv
U02.02	Last Fault	Displays the most recent fault after being reset (same as U03.01)	--	Basic/Adv
U02.03	Frequency Reference @ Fault	Freq ref when fault was detected	Hz	Basic/Adv
U02.04	Output Frequency @ Fault	Output freq when fault was detected	Hz	Basic/Adv
U02.05	Output Current @ Fault	Output current when fault was detected	A	Basic/Adv
U02.06	Motor Speed @ Fault (OLV Only)	Motor speed when fault was detected	Hz	Adv
U02.07	Output Voltage @ Fault	Output voltage when fault was detected	V	Basic/Adv
U02.08	DC Bus Voltage @ Fault	DC Bus voltage when fault was detected	V	Basic/Adv
U02.09	Output Power @ Fault	Output power when fault was detected	kW	Basic/Adv
U02.11	Input Terminal Status @ Fault	Input terminal status when fault was detected	--	Basic/Adv
U02.12	Output Terminal Status @ Fault	Output terminal status when fault was detected	--	Basic/Adv
U02.13	Operation Status @ Fault	Inverter status before fault was detected	--	Basic/Adv
U02.14	Elapsed Time @ Fault	Elapsed time when fault was detected	hr	Basic/Adv
U02.15	Speed Reference During Soft Start @ Fault	Speed reference during soft start at previous fault	%	Basic/Adv
U02.16	Motor q-Axis Current During Fault	---	--	Adv
U02.17	Motor d-Axis Current During Fault	---	--	Adv

## ***Fault History***

<b>Parameter</b>			<b>Access</b>	
<b>Code</b>	<b>Name</b>	<b>Function</b>	<b>Units</b>	
			<b>Level</b>	
U03.01	Last Fault	Displays most recent fault detected	--	Adv
U03.02	Fault Message 2	Displays second most recent fault	--	Adv
U03.03	Fault Message 3	Displays third most recent fault	--	Adv
U03.04	Fault Message 4	Displays fourth most recent fault	--	Adv
U03.05	Fault Message 5	Displays fifth most recent fault	--	Adv
U03.06	Fault Message 6	Displays sixth most recent fault	--	Adv
U03.07	Fault Message 7	Displays seventh most recent fault	--	Adv
U03.08	Fault Message 8	Displays eighth most recent fault	--	Adv
U03.09	Fault Message 9	Displays ninth most recent fault	--	Adv
U03.10	Fault Message 10	Displays tenth most recent fault	--	Adv
U03.11	Elapsed Time 1	Elapsed time of most recent fault	--	Adv
U03.12	Elapsed Time 2	Elapsed time of second most recent fault	--	Adv
U03.13	Elapsed Time 3	Elapsed time of third most recent fault	--	Adv
U03.14	Elapsed Time 4	Elapsed time of fourth most recent fault	--	Adv
U03.15	Elapsed Time 5	Elapsed time of fifth most recent fault	--	Adv
U03.16	Elapsed Time 6	Elapsed time of sixth most recent fault	--	Adv
U03.17	Elapsed Time 7	Elapsed time of seventh most recent fault	--	Adv
U03.18	Elapsed Time 8	Elapsed time of eighth most recent fault	--	Adv
U03.19	Elapsed Time 9	Elapsed time of ninth most recent fault	--	Adv
U03.20	Elapsed Time 10	Elapsed time of tenth most recent fault	--	Adv

<b>Parameter Code</b>	<b>Name</b>	<b>Function</b>	<b>Units</b>	<b>Access Level</b>
U03.21	Accumulated Operations	Displays the number of FWD and REV commands	--	Adv
U03.22	U03.21 Rollovers	Increments when U03.21 reaches 65535. U03.21 is set to zero.	--	Adv
U03.23	Overload/Load Check Count	Displays the number of OL1, OL2 and LC faults	--	Adv

### *Maintenance*

<b>Parameter Code</b>	<b>Name</b>	<b>Function</b>	<b>Units</b>	<b>Access Level</b>
U04.01	Elapsed Time	Cummulative operation time of drive. Defined by O03.02	hr	Adv
U04.03	Cooling Fan Operation Time	Cummulative operating time of cooling fan.	hr	Adv
U04.04	Cooling Fan Maintenance		%	Adv
U04.05	Capacitor Maintenance		%	Adv
U04.06	Soft Charge Bypass Relay Maintenance		%	Adv
U04.07	IGBT Maintenance		%	Adv
U04.08	Heatsink Temperature		°C	Adv
U04.09	LED Check	Lights all segments of the LED to verify that the display is working properly.		
U04.10	kWh; Lower 4 Digits		kWh	Adv
U04.11	kWh; Upper 5 Digits		kWh	Adv
U04.12	CPU Resources Used		--	Adv
U04.13	Peak Hold Current		--	Adv
U04.14	Peak Hold Output Frequency		--	Adv
U04.16	Motor Overload (oL1) Detection Level		--	Adv
U04.17	Motor Overload (oL2) Detection Level		--	Adv
U04.18	Frequency Reference Source Selection		--	Adv
U04.19	Frequency Reference Memobus		--	Adv
U04.20	Output Frequency Reference (decimal)		--	Adv
U04.21	Run Command Selection Results		--	Adv
U04.22	Memobus Communication Reference		--	Adv
U04.23	Not Used		--	Adv

### *Motor Control Monitor*

<b>Parameter Code</b>	<b>Name</b>	<b>Function</b>	<b>Units</b>	<b>Access Level</b>
U06.01	Motor Secondary Current (Iq)		%	Adv
U06.02	Motor Excitation Current (Id)		%	Adv
U06.03	ASR Input		%	Adv
U06.04	ASR Output		%	Adv



<b>Paramter Code</b>	<b>Name</b>	<b>Function</b>	<b>Units</b>	<b>Access Level</b>
U06.05	Output Voltage Reference (Vq)		V	Adv
U06.06	Output Voltage Reference (Vd)		V	Adv
U06.07	ACR (q) Output		%	Adv
U06.08	ACR (d) Output		%	Adv
U06.20	Frequency Reference Bias (Up/Down2)		%	Adv
U06.21	Offset Frequency		%	Adv
U06.36	GAIA Communication Error		--	Adv
U06.37	LUNA Communication Error		--	Adv
U06.38	Option Card Error		--	Adv

This page intentionally left blank.

# *Chapter* **6**

## **Troubleshooting IMPULSE•G+ Mini**

This page intentionally left blank.

# Troubleshooting the Drive

In this troubleshooting section, “check” means investigating whether an item is functioning and in an acceptable physical condition, and then taking corrective action (adjusting, fixing, replacing, etc.) as necessary. In the Corrective Action column, you may not have to perform all of the steps to correct the problem.

## Maintenance and Inspection

This section describes basic maintenance and inspection procedures for the IMPULSE•G+ Mini.

Component	Check	Corrective Action
External terminals, connectors, mounting screws, etc.	Loose screws or connectors	Securely tighten.
Heatsink	Build-up of dust and dirt	Blow with dry, compressed air (57-86 psi).
Printed Circuit Board (PCB)	Accumulation of conductive dust or oil	Blow with dry, compressed air (57-86 psi). If dust and oil cannot be removed, replace the board.
Cooling Fan	Abnormal noise and vibration	Clean or replace the fan.
Power Components	Accumulation of dust or dirt	Blow with dry, compressed air (57-86 psi).

### Alarm and Fault classes are described as follows:

- Major Fault: Brake is set, ALM indicator LED remains lit, fault is displayed on keypad and brake contact output (terminals MC, MB, & MA) is deactivated. In order to continue operation the reset key must be pressed, a multi-function input set for fault reset or power must be cycled.
- Fault (minor): Brake is set, ALM/indicator LED flashes, fault code flashes in the keypad brake contact output (terminals MC, MB, & MA) is deactivated. The reset key does not need to be pressed. The drive will attempt to run again at the next run command.
- Alarm (Warning): Brake does not set, operation continues, ALM/indicator LED flashes, fault code flashes, brake contact output (terminals MC, MB, & MA) stay activated.

## Motor Faults and Corrective Actions

Symptom	Corrective Action
Analog frequency reference is not stable (drifting).	<ol style="list-style-type: none"> <li>1. Stabilize the analog source.</li> <li>2. Increase B02.02.</li> <li>3. Increase B05.01, B05.02.</li> </ol>
No motor rotation.	<ol style="list-style-type: none"> <li>1. Verify that power is on (Charge LED).</li> <li>2. Verify that the keypad display is not showing a fault.</li> <li>3. Verify that the run command is input to the drive (U01.10).</li> <li>4. Check if motor stalled due to excessive current (U01.03).</li> </ol>
Motor rotation is in the wrong direction.	<ol style="list-style-type: none"> <li>1. Verify FWD/REV or UP/DN is wired correctly at the interface card.</li> <li>2. Switch any two leads on U/T1, V/T2, or W/T3 going to the motor.</li> <li>3. Check parameter B03.04.</li> </ol>

<b>Symptom</b>	<b>Corrective Action</b>
Motor rotates, but at minimum speed only.	<ol style="list-style-type: none"> <li>1. Check wiring of speed inputs and verify inputs (U01.10).</li> <li>2. Verify speed reference setting (A01.04).</li> <li>3. Verify reference and run source settings are correct (B03.01, B03.02).</li> <li>4. Verify reference priority setting (B01.18).</li> <li>5. Check if motor stalled due to excessive current (U01.03).</li> </ol>
Motor RPM too high or too low.	<ol style="list-style-type: none"> <li>1. Compare motor nameplate specifications with E2 parameters.</li> <li>2. Check maximum frequency setting (E01.04).</li> <li>3. Check minimum frequency setting (E01.09).</li> </ol>

## Drive Faults, Alarms and Indicators

<b>Fault Code</b>	<b>Fault or Indicator Name/Description</b>	<b>Corrective Action</b>
<b>BB</b> (flashing) Base Block	<b>External Base Block Indicator.</b> The flashing base block signal is the result of a multi-function input in the terminal strip. The base block indicates that the drive's IGBTs have been disabled. The motor will begin coasting when the base block input is received. If a RUN command is still present when the BB signal is removed, the output voltage will be restored to the previous operating level and operation will continue at the previously commanded frequency.	<ol style="list-style-type: none"> <li>1. Check constants H01.01 through H01.07 for proper programming.</li> <li>2. Check terminal status. (U01.10)</li> </ol>
<b>BE0</b> (flashing) Brake Ans Lost	<b>Brake answer back signal is lost during run.</b> While running, the multi-function input brake answer back is lost.	<ol style="list-style-type: none"> <li>1. Check brake answer back circuit.</li> <li>2. Check terminal status. (U01.10)</li> </ol>
<b>BE4</b> (flashing) Brake Answer 1	<b>Brake Answer-Back, Brake not Released.</b> At Start, Brake Answer-back is not input within predetermined time (C08.04) after electric brake release command is output—Electric brake not released.	<ol style="list-style-type: none"> <li>1. Check brake answer back circuit.</li> <li>2. Increase the value of C08.04.</li> <li>3. Check terminal status (U01.10).</li> </ol>
<b>BE5</b> (flashing) Brake Answer 2	<b>Brake Answer-Back At Stop.</b> At Stop, Brake Answer-back signal is not removed within predetermined time (C08.11) after electric brake release command is removed—Electric brake not closed.	<ol style="list-style-type: none"> <li>1. Check brake answer back circuit.</li> <li>2. Increase the value of C08.11 time.</li> </ol>
<b>CALL</b> (flashing)	<b>Serial Communication Transmission Error.</b> Control data is not received correctly after power supply is turned ON for 2 sec.	<ol style="list-style-type: none"> <li>1. Check serial device connections.</li> <li>2. Ensure drive is properly programmed for serial communication.</li> </ol>
<b>CE</b> Memobus Com Err	<b>MEMOBUS/Modbus Communication Error.</b> Serial communications data corrupted.	<ol style="list-style-type: none"> <li>1. Check serial connections (R+, R-, S+, &amp; S-).</li> <li>2. Check H05.01 through H05.03 for proper programming.</li> </ol>
<b>CF</b> Control Fault	<b>Control Fault.</b> A torque limit was reached for 3 seconds or longer while in open Loop Vector.	<ol style="list-style-type: none"> <li>1. Perform auto tune.</li> <li>2. Check motor parameters.</li> </ol>
<b>COF</b>	<b>Current Offset Fault.</b> The drive automatically adjusts the current offset, the calculated value exceeded the allowable setting range.	<ol style="list-style-type: none"> <li>1. Press reset.</li> <li>2. Check brake.</li> <li>3. Check brake contact.</li> </ol>

<b>Fault Code</b>	<b>Fault or Indicator Name/Description</b>	<b>Corrective Action</b>
CPF02	<b>A/D Conversion Error.</b> An A/D conversion error occurred.	<ol style="list-style-type: none"> <li>1. Cycle power to the drive.</li> <li>2. Ensure that the control board terminals and wiring are shielded from electrical noise.</li> <li>3. Check resistance of potentiometer.</li> <li>4. Replace the drive.</li> </ol>
CPF03	<b>PWM Data Error.</b> There is a problem with the PWM data.	<ol style="list-style-type: none"> <li>1. Cycle power to the drive.</li> <li>2. Replace the control board.</li> </ol>
CPF06	<b>EEPROM Data Error.</b> There is an error in the data saved to EEPROM.	<ol style="list-style-type: none"> <li>1. Cycle power to the drive.</li> <li>2. If the problem continues, replace the drive.</li> </ol>
CPF07	<b>Terminal Board Communications Error.</b> A communication error occurred at the terminal board.	<ol style="list-style-type: none"> <li>1. Cycle power to the drive.</li> <li>2. Check connections on the control board.</li> </ol>
CPF08	<b>EEPROM Serial Communications Fault.</b> EEPROM communications are not functioning properly.	<ol style="list-style-type: none"> <li>1. Cycle power to the drive.</li> <li>2. If the problem continues, replace the drive.</li> </ol>
CPF11	<b>RAM Fault.</b>	<ol style="list-style-type: none"> <li>1. Cycle power to the drive.</li> <li>2. Replace the drive.</li> </ol>
CPF12	<b>FLASH Memory Fault.</b> Problem with the ROM (FLASH memory).	<ol style="list-style-type: none"> <li>1. Cycle power to the drive.</li> <li>2. Replace the drive.</li> </ol>
CPF13	<b>Watchdog Circuit Exception.</b> Control circuit damage.	<ol style="list-style-type: none"> <li>1. Cycle power to the drive.</li> <li>2. Replace the drive.</li> </ol>
CPF14	<b>Control Circuit Fault.</b> CPU Error (CPU operates incorrectly due to noise, etc.)	<ol style="list-style-type: none"> <li>1. Cycle power to the drive.</li> <li>2. Replace the drive.</li> </ol>
CPF16	<b>Clock Fault.</b> Standard clock error.	<ol style="list-style-type: none"> <li>1. Cycle power to the drive.</li> <li>2. Replace the drive.</li> </ol>
CPF17	<b>Timing Fault.</b> A timing error occurred during an internal process.	<ol style="list-style-type: none"> <li>1. Cycle power to the drive.</li> <li>2. Replace the drive.</li> </ol>
CPF18 and CPF19	<b>Control Circuit Fault.</b> CPU error (CPU operates incorrectly due to noise, etc.)	<ol style="list-style-type: none"> <li>1. Cycle power to the drive.</li> <li>2. Ensure that the control board terminals and wiring are shielded from electrical noise.</li> <li>3. Replace the drive.</li> </ol>
CPF20 and CPF21	<b>RAM fault, FLASH memory error, watchdog circuit exception.</b>	<ol style="list-style-type: none"> <li>1. Cycle power to the drive.</li> <li>2. Replace the drive.</li> </ol>
CPF22	<b>A/D Conversion Fault.</b> A/D conversion error.	<ol style="list-style-type: none"> <li>1. Cycle power to the drive.</li> <li>2. Ensure that the control board terminals and wiring are shielded from electrical noise.</li> <li>3. Check resistance of potentiometer.</li> </ol>
CPF23	<b>PWM Feedback Fault.</b> PWM feedback error.	<ol style="list-style-type: none"> <li>1. Cycle power to the drive.</li> <li>2. Replace the drive.</li> </ol>
CPF24	<b>Drive Capacity Signal Fault.</b> Entered a capacity that does not exist (checked when the drive is powered up).	<ol style="list-style-type: none"> <li>1. Cycle power to the drive.</li> <li>2. Replace the drive.</li> </ol>
CRST	Cannot reset. External fault occurred and reset button was pressed before motor was completely stopped. Fault reset was being executed when a RUN command is executed during a fault.	<ol style="list-style-type: none"> <li>1. Wait for motor to come to complete stop.</li> <li>2. Reset fault before issuing a RUN command.</li> </ol>

<b>Fault Code</b>	<b>Fault or Indicator Name/Description</b>	<b>Corrective Action</b>
<b>DNE</b> Drive not ready	User is trying to give a run command while a FWD or REV is present at Power Up.	1. Check input terminals. 2. Check H01.01 to H01.07 programming.
<b>EF</b> ( <i>flashing</i> ) External Fault	Both FORWARD/UP and REVERSE/DOWN commands are input at same time for 500 msec or longer.	1. Check control input wiring. 2. Check the sequence of operation.
<b>EF0</b> Optional External Fault	External fault input from communication option card.	1. Check communication option card connection and signals. 2. Check external device for any fault(s)
<b>EF1</b> External Fault 1	External fault occurs on Terminal S1.	1. Check constant H01.01 for proper programming. 2. Check the conditions for input terminal S1 (U01.10).
<b>EF2</b> External Fault 2	External fault occurs on Terminal S2.	1. Check constant H01.02 for proper programming. 2. Check the conditions for input terminal S2 (U01.10).
<b>EF3</b> External Fault 3	External fault occurs on Terminal S3.	1. Check constant H01.03 for proper programming. 2. Check the condition for input terminal S3 (U01.10).
<b>EF4</b> External Fault 4	External fault occurs on Terminal S4.	1. Check constant H01.04 for proper programming. 2. Check the condition for input terminal S4 (U01.10).
<b>EF5</b> External Fault 5	External fault occurs on Terminal S5.	1. Check constant H01.05 for proper programming. 2. Check the condition for input terminal S5 (U01.10).
<b>EF6</b> External Fault 6	External fault occurs on Terminal S6.	1. Check constant H01.06 for proper programming. 2. Check the condition for input terminal S6 (U01.10).
<b>EF7</b> External Fault 7	External fault occurs on Terminal S7.	1. Check constant H01.07 for proper programming. 2. Check the condition for input terminal S7 (U01.10).
<b>GF</b> Ground Fault	<b>Ground Fault.</b> Current shorted to ground exceeded 50% of rated current on output side of the drive. Setting L08.09 to 1 enable ground fault detection in models 2025 and 4014 or larger.	1. Disconnect motor from drive and check it for shorts using a megger. 2. Ensure that R/C Surge Suppressors are used across all brake contactor coils to prevent disturbance by electrical transients.
<b>HBB</b> Hardware BB	<b>Hardware Base Block.</b> The Safe Disable Input channel is open.	1. Check if external safety circuit tripped and disabled the drive. 2. If the Safe Disable function is not utilized, check if the terminals HC and H1 are linked.
<b>LC</b> Load Check Err	<b>Load Check Alarm.</b> This fault is displayed when the load detected is greater than the measured load during the Load Check set up process for a particular LC Zone.	1. Reduce Load. 2. Decrease the LC Sensitivity (higher value). 3. Increase the settings for the particular LC Zone where the fault occurred by 1.
<b>LC dn</b> LC Done	<b>Load Check Done Alarm.</b> This alarm is displayed after the LC set up process is done. The alarm will clear when the Down command is pressed and completes the LC set up process.	--



<b>Fault Code</b>	<b>Fault or Indicator Name/Description</b>	<b>Corrective Action</b>
<b>LF</b> Output Phase Loss	An open phase occurred at the inverter output.	<ol style="list-style-type: none"> <li>1. Check for broken wires in output cable.</li> <li>2. Check for open winding in the motor.</li> <li>3. Check for loose terminals.</li> </ol>
<b>LL1</b> <i>(flashing)</i> Lower Limit 1 Err	<b>Lower Limit 1—SLOW DOWN Indicator.</b> Lower Limit 1—SLOW DOWN is input (switch status is changed).	<ol style="list-style-type: none"> <li>1. May not require corrective action.</li> <li>2. Check the position of the Limit Switch.</li> <li>3. Check the condition of the Limit Switch.</li> <li>4. Check the conditions of/for input terminal H01.XX (U01.10).</li> </ol>
<b>LL2</b> <i>(flashing)</i> Lower Limit 2 Err	<b>Lower Limit 2—STOP Indicator.</b> Lower Limit 2—STOP is input (switch status is changed).	<ol style="list-style-type: none"> <li>1. May not require corrective action.</li> <li>2. Check the position of the Limit Switch.</li> <li>3. Check the condition of the Limit Switch.</li> <li>4. Check the conditions of/for input terminal H01.XX (U01.10).</li> </ol>
<b>MNT</b> Maintenance Req'd	<b>Maintenance Required Alert.</b> Running time has exceeded C12.05	<ol style="list-style-type: none"> <li>1. Reset timer by MFI=5A or depress Mode/Service key three times and enter within 2 seconds.</li> </ol>
<b>OC</b> Over Current	Output current exceeds 200% of inverter rated output current.	<ol style="list-style-type: none"> <li>1. Check for a phase-to-phase short in the motor or wiring using a megger.</li> <li>2. Extend the acceleration/deceleration time.</li> <li>3. Check torque limit setting.</li> </ol>
<b>OH</b> <i>(flashing)</i> Heatsink Over temp	<b>Overheat Pre-Alarm.</b> Heatsink is overheating. The temperature of the inverter's heatsink exceeded the setting in L08.02.	<ol style="list-style-type: none"> <li>1. The inverter cooling fan has stopped.</li> <li>2. Reduce the ambient temperature.</li> </ol>
<b>OH1</b> Heatsink MaxTemp	<b>Overheat Fault.</b> There are two situations that result in an overheat fault. The first occurs when the measured heat sink exceeds 105°C. The second is a result of a fault in the internal 24VDC cooling fan.	<ol style="list-style-type: none"> <li>1. Ensure that the heat sink cooling fans are functioning.</li> <li>2. Ensure that the heat sink is free from dirt and debris.</li> </ol>
<b>OH2</b> <i>(flashing)</i> Overheat 2	<b>Overheat Alarm.</b> Signal is input by external terminal. H01.XX=39	<ol style="list-style-type: none"> <li>3. Ensure that the inverter's ambient temperature is within specification.</li> <li>4. Replace the 24VDC fan.</li> <li>5. Replace the heat sink thermistor(s).</li> </ol>
<b>OH3</b> Motor Overheat 1	<b>Motor Overheating 1.</b> Thermistor analog input detected motor overheating. See L01.03	<ol style="list-style-type: none"> <li>1. Check the motor rated current value, E02.01.</li> <li>2. Increase cycle time or reduce the load.</li> </ol>
<b>OH4</b> Motor Overheat 2	<b>Motor Overheating 2.</b> Thermistor analog input detected motor overheating. See L01.04	
<b>OL1</b> Motor Overloaded	<b>Motor Overload Fault.</b> Inverter output exceeded the motor overload level.	<ol style="list-style-type: none"> <li>1. Ensure drive is programmed with proper motor full load Amps (E02.01).</li> <li>2. Reduce the load.</li> </ol>
<b>OL2</b> INV Overload	<b>Inverter Overload Fault.</b> Inverter output exceeded the inverter overload level.	<ol style="list-style-type: none"> <li>1. Reduce the load.</li> <li>2. Extend the acceleration time.</li> </ol>
<b>OL8</b> Klixon	<b>Klixon Circuit Alarm.</b> Input by MFI data 56 or 57.	<ol style="list-style-type: none"> <li>1. Check motor for overtemp.</li> <li>2. Check Klixon circuit.</li> </ol>
<b>OPE01</b> kVA Selection	<b>kVA Setting Fault.</b> Inverter kVA setting range is incorrect.	<ol style="list-style-type: none"> <li>1. Check O02.04 constant for proper kVA.</li> </ol>
<b>OPE02</b>	<b>Parameter Range Setting Error.</b> Parameter settings are set outside the parameter range.	<ol style="list-style-type: none"> <li>1. Press enter to view parameter.</li> <li>2. Change parameter to appropriate setting.</li> </ol>

<b>Fault Code</b>	<b>Fault or Indicator Name/Description</b>	<b>Corrective Action</b>
<b>OPE03</b> Terminal	<b>Multi-Function Input Setting Fault.</b> Set values other than “F” and “FF” are duplicated.	1. Check the settings for H01.01 to H01.07, verify that the same input is not used twice.
<b>OPE04</b> Terminal	<b>Parameters do not match.</b> The drive, control board, or terminal board has been replaced, and the parameter settings between the controller board or terminal board do not match.	1. Press ENTER to view the parameter. 2. Change parameter(s) to appropriate settings. 3. Set A01.05 = 5550.
<b>OPE07</b> Analog Selection	<b>Multi-Function Analog Input Setting Fault.</b> Set values other than 00 and 0F are duplicated.	1. Check setting for H03.02 and H03.10. Verify that the same value is not used twice.
<b>OPE08</b> Terminal	<b>Selection Parameter error.</b> A parameter has been changed that is not available in the present control method.	1. Undo the last parameter change (if known). 2. Scroll through modified constants for obvious setting errors. 3. Perform a user initialize (A01.05=1110). <b>CAUTION: All settings will be restored to the factory defaults.</b>
<b>OPE10</b> V/f Ptrn Setting	<b>V/f Parameter Setting Error.</b>	1. Check Parameters E01.04 to E01.11.
<b>OPE23</b> Load Check	<b>Check C05.04 ≤ C05.07 ≤ C05.09.</b>	1. Load Check setting error.
<b>OT1</b> Overtorque Det 1	<b>Overtorque Detection Level 1 Fault.</b> Current is higher than set value (L06.02) for more than set time (L06.03).	1. Check for proper programming of L06.02 and L06.03.
<b>OT2</b> Overtorque Det 2	<b>Overtorque Detection Level 2 Fault.</b> Defined by L06.05. Alarm defined by L06.04.	1. Check for proper programming for L06.XX constant.
<b>OV</b> DC Bus Overvolt	<b>Overvoltage Fault.</b> The DC bus voltage exceeded the overvoltage level. Detection level: 230V class—approx. 410V 460V class—approx. 820V	1. Extend the deceleration time. 2. Check for proper DBU operation. 3. Check the resistor. 4. Check the line voltage. 5. If on a load brake hoist, check the gear box.
<b>OV</b> (flashing) DC Bus Overvolt	<b>Overvoltage Fault.</b> Overvoltage occurs during stop. Main circuit DC voltage rises above the detection level while the drive output is off. Detection level: 410V or more for 230V, 820V or more for 460V.	1. Check the line voltage.
<b>PF</b> Input Pha Loss	<b>Input Phase Loss Fault.</b> Inverter input power supply has open phase.	1. Check the line voltage. 2. Remove power. 3. Retighten the input terminal screws. 4. Check line fuses.
<b>RR</b> DynBrk Transistr	<b>Braking Transistor Fault.</b> Internal Braking transistor failed.	1. Verify that the external braking resistor is connected to the proper terminals. 2. Confirm that the proper resistor is installed. 3. Check for a short circuit across the braking resistor.
<b>UL1</b> Upper Limit 1 Err	<b>Upper Limit 1—SLOW DOWN Indicator.</b> Upper Limit 1—SLOW DOWN switch status is changed.	1. May not require corrective action. 2. Check the position of the Limit Switch. 3. Check the condition of the Limit Switch. 4. Check the conditions of/for terminal H01.XX (U01.10).

<b>Fault Code</b>	<b>Fault or Indicator Name/Description</b>	<b>Corrective Action</b>
<b>UL2</b> Upper Limit 2 Err	<b>Upper Limit 2—STOP Indicator.</b> Upper Limit 2—STOP switch status is changed.	<ol style="list-style-type: none"> <li>1. May not require corrective action.</li> <li>2. Check the position of the Limit Switch.</li> <li>3. Check the condition of the Limit Switch.</li> <li>4. Check the conditions of/for terminal H01.XX (U01.10)</li> </ol>
<b>UL3</b> Upper Limit 3 Err	<b>Upper Limit 3—Weighted Stop.</b> Upper Limit weighted limit switch tripped.	<ol style="list-style-type: none"> <li>1. May not require corrective action.</li> <li>2. Check the position of the Limit Switch.</li> <li>3. Check the condition of the Limit Switch.</li> <li>4. Check the conditions of/for terminal H01.XX (U01.10)</li> </ol>
<b>UT1</b> Undertorque Det 1	<b>Undertorque Detection 1.</b> The current is less than L06.02 for more than L06.03.	<ol style="list-style-type: none"> <li>1. Check settings.</li> <li>2. Check motor coupling.</li> </ol>
<b>UT2</b> Undertorque Det 2	<b>Undertorque Detection 2.</b> The current is less than L06.05 for more than L06.06.	<ol style="list-style-type: none"> <li>1. Check settings.</li> <li>2. Check motor coupling.</li> </ol>
<b>UV</b> (Flashing) DC Bus Undervolt	<b>Undervoltage Fault.</b> Undervoltage status occurs for more than 2 sec during STOP. Input voltage drops below 190V DC or less for 230V AC class, 380V DC or less for 460V AC class.	<ol style="list-style-type: none"> <li>1. Check the power source wiring.</li> <li>2. Replace any bad branch fuses.</li> <li>3. Check collector system.</li> </ol>
<b>UV1</b> DC Bus Undervolt	<b>Undervoltage 1 Fault.</b> Undervoltage status occurs for more than 2 sec during RUN command. Input voltage drops below 190V DC or less for 230V AC class, 380V DC or less for 460V AC class.	<ol style="list-style-type: none"> <li>1. Check power supply wiring.</li> <li>2. Correct the line voltage.</li> <li>3. Check collector system.</li> </ol>
<b>UV2</b> CTL PS Undervolt	<b>Undervoltage 2 Fault.</b> The inverter detected a loss of the 24V logic power supply voltage.	<ol style="list-style-type: none"> <li>1. Check power supply wiring.</li> <li>2. Correct the line voltage.</li> <li>3. Check collector system.</li> </ol>
<b>UV3</b> MC Answerback	<b>MC Fault.</b> The pre-charge contactor opened during operation.	<ol style="list-style-type: none"> <li>1. Check power supply wiring.</li> <li>2. Correct the line voltage.</li> <li>3. Check collector system.</li> <li>4. Wait 30-45 seconds before restarting drive after auto shut down.</li> </ol>

## Fault Display and Corrective Actions at Auto-Tuning

The following are fault displays and corrective actions at auto-tuning. If any of the following faults are found, the digital operator displays that fault's contents; the motor coasts to stop if it is under operation. Fault contact output or minor fault contact output does not operate.

Fault Display	Fault or Indicator Name/Description	Corrective Action
Er-01 Fault	<b>Motor Data Fault.</b> Motor data was entered incorrectly for auto-tuning. Relationship between motor HP and motor rated current fault. Input motor rated current and motor no-load current fault don't match.	<ul style="list-style-type: none"> <li>• Check the T1 parameters.</li> <li>• Check inverter and motor capacity</li> <li>• Check motor rated current and no-load current.</li> </ul>
Er-02 Minor Fault	<b>Alarm.</b> The minor fault is detected during auto-tuning.	<ul style="list-style-type: none"> <li>• Check the T1 parameters.</li> <li>• Check wirings</li> <li>• Disconnect motor from load.</li> </ul>
Er-03 STOP Key	<b>STOP Key Input.</b> The stop key is pressed during auto-tuning.	
Er-04 Resistance	<b>Line to Line Resistance Fault.</b> Auto-tuning is not completed within the expected time. The auto-tuning is outside the parameter setting.	
Er-05 No-Load Current	<b>No-load Current Fault.</b> Auto-tuning is not completed within the expected time. The auto-tuning is outside the parameter setting.	<ul style="list-style-type: none"> <li>• Check the T1 parameters.</li> <li>• Check motor wiring.</li> <li>• Disconnect motor from load.</li> </ul>
Er-08 Rated Slip	<b>Rated Slip Fault.</b> Auto-tuning is not completed within the expected time. The auto-tuning is outside the parameter setting.	
Er-09 Accelerate	<b>Acceleration Fault (rotating auto-tuning only).</b> The motor did not accelerate at the expected time.	<ul style="list-style-type: none"> <li>• Increase B05.01 (acceleration time).</li> <li>• If C07.01 and C07.02 (torque limit value) are decreased, increase values.</li> <li>• Disconnect motor from load.</li> </ul>
Er-11 Motor Speed	<b>Motor Speed Fault (rotating auto-tuning only).</b> The motor speed was over 100% at auto-tuning (vector control without PG only).	<ul style="list-style-type: none"> <li>• Increase B05.01 (acceleration time).</li> <li>• Disconnect motor from load.</li> </ul>
Er-12 I.det.Circuit	<b>Current Detection Fault.</b> Current exceeded the motor rated current.	<ul style="list-style-type: none"> <li>• Release brake.</li> <li>• Check for open motor lead.</li> </ul>
End 1 V/f Oversetting	<b>Excess V/f setting * (rotating auto-tuning only).</b> The torque reference exceeded 20% and no load current exceeded 80%.	<ul style="list-style-type: none"> <li>• Check the T1 parameters.</li> <li>• Disconnect the motor from the load.</li> </ul>
End 2 Saturation	<b>Motor Iron Core Saturation Coefficient Fault (rotating auto-tuning only).</b> Since the motor iron core saturation coefficient could not be auto-tuned within the set time, tentative value is set in the iron core saturation coefficient.	<ul style="list-style-type: none"> <li>• Check the T1 parameters.</li> <li>• Check motor wiring.</li> <li>• Disconnect the motor from the load</li> </ul>
End 3 Rated FLA Alm	<b>Rated Current Set Alarm.</b> Motor current during tuning was greater than the set value.	<ul style="list-style-type: none"> <li>• Check E02.01.</li> <li>• Check T01.04.</li> </ul>

*NOTE: \* Excessive V/f set value, motor iron core saturation coefficient fault, and rated current set alarm are all displayed after the auto tuning is completed.*

# Power Section Check



## WARNING

Do NOT touch any circuit components while AC main power is on or immediately after the main AC power is disconnected from the unit. You must wait until the red “CHARGE” lamp is extinguished. It may take as long as 10 minutes for the charge on the main DC bus capacitors to drop to a safe level. Failure to adhere to this warning could result in serious injury.

### Power Off Checks

To perform a power section check, remove the drives main and control wiring from the terminal strips. Obtain reading as specified in the table on the next page, and ensure that the reading falls within the normal reading range.

Test equipment - Analog Ohmmeter set R x 1 scale or digital multimeter set to the diode check.

Device	VOM (on Rx1 Scale)		Normal Reading (Analog Meter)	Normal Reading (Digital Meter)
	Positive Lead	Negative Lead		
Input Rectifier Bridge *1	L1	+	7-100Ω	Approximately 0.5 V
	L2	+		
	L3	+		
	-	L1		
	-	L2		
	-	L3		
	L1	-	Infinite Ω	OL Displayed
	L2	-		
	L3	-		
	+	L1		
+	L2			
+	L3			
Bus Capacitors	+	-	Observe gradually increasing resistance	Observe gradually increasing voltage to OL
Pre-charge Resistor	-	Across the Resistors	100 Ω or less	-
Output Transistors *2 *3	T1	+	7-100 Ω	Approximately 0.5V
	T2	+		
	T3	+		
	-	T1		
	-	T2		
	-	T3		
	T1	-	Infinite Ω	OL Displayed
	T2	-		
	T3	-		
	+	T1		
+	T2			
+	T3			
Braking Diode	B2	B1	10 Ω	0.5 V
	B1	B2	Infinite Ω	OL Displayed
	B2	-	Infinite Ω	OL Displayed
	-	B2	Infinite Ω	0.5 V

\*1. “+” could be any one of three (+) terminals which are labeled as A1, A2, and A3.

\*2. If the bus fuse is blown you must install a jumper across the fuse terminals to get accurate resistance measurements.\*3.

\*3. If the pre-charge resistor is open, you will read infinite W between + and any output terminal unless you install a temporary jumper across the resistor.

## Braking Circuit

Test Equipment - Analog Ohmmeter set to R x 1 scale or digital multimeter set to the diode check.

Step No.	Ohmmeter Positive Lead	Ohmmeter Negative Lead	Expected Reading (Analog Meter)	Expected Reading (Digital Meter)
1	Connect to B2	Connect to B1	10 Ohms	0.5 Volts
2	Connect to B1	Connect to B2	Infinite Ohms	OL displayed
3	Connect to B2	–	Infinite Ohms	OL displayed
4	–	Connect to B2	Infinite Ohms	OL displayed

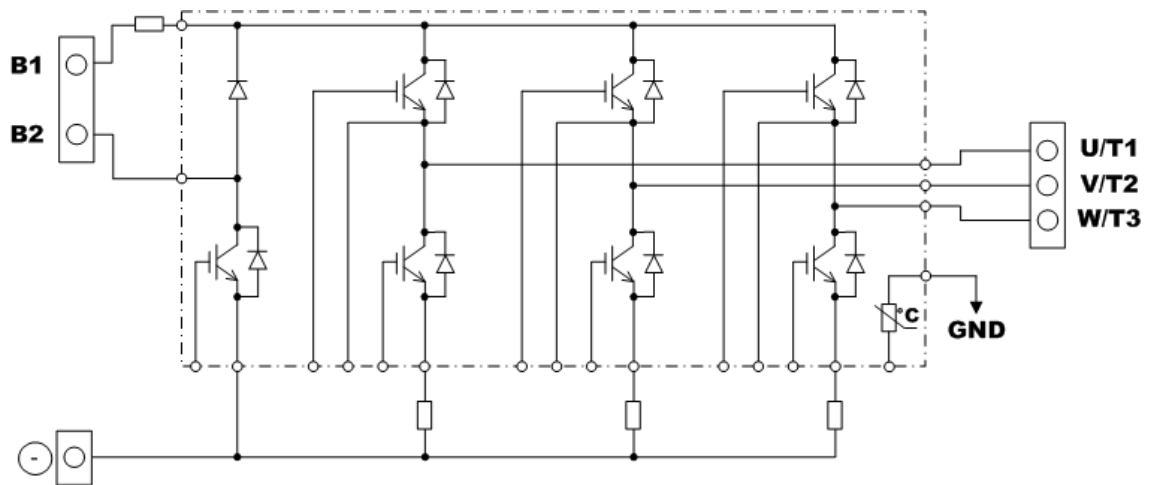

*Figure 6-1: Braking Circuit*

*A p p e n d i x* **A**

**IMPULSE•G+ Mini Advanced  
Parameter Listing**

This page intentionally left blank.



## IMPULSE•G+ Mini Parameter Listing

Parameter	Parameter Name	Default	Range	Units	Reference Page
A01.01	Access Level 0000: User 0001: Basic 0002: Advanced	0001	0000~0001	--	4-13
A01.02	Control Method 00: V/f 02: OLV	00	00, 02	--	4-13
A01.03	Motion 00: Traverse 01: Hoist 04: Braketronics	01	00, 01, 04	--	4-14
A01.04	Speed Reference 00: 2-Speed Multi-Step 01: 3-Speed Multi-Step 02: 5-Speed Multi-Step 03: 2-Step Infinitely Variable 04: 3-Step Infinitely Variable 05: Analog - Uni-Polar	01	00~05	--	4-14
A01.05	Initialize 0000: No Initialize 1110: User Initialize 5550: Moves modified parameters from terminal board to control board	0000	0000~5550	--	4-18
A01.06	Password 1	0000	0000~9999	--	4-18
A01.08	Password 2	0000	0000~9999	--	4-19
B01.01	Frequency Reference 1	15.00*	0.00~150.00	Hz	5-3
B01.02	Frequency Reference 2	30.00*	0.00~150.00	Hz	5-3
B01.03	Frequency Reference 3	60.00*	0.00~150.00	Hz	5-3
B01.04	Frequency Reference 4	0.00*	0.00~150.00	Hz	5-3
B01.05	Frequency Reference 5	0.00*	0.00~150.00	Hz	5-3
B01.06	Frequency Reference 6	0.00*	0.00~150.00	Hz	5-3
B01.07	Frequency Reference 7	0.00*	0.00~150.00	Hz	5-3
B01.08	Frequency Reference 8	0.00*	0.00~150.00	Hz	5-3
B01.09	Frequency Reference 9	0.00*	0.00~150.00	Hz	5-3
B01.10	Frequency Reference 10	0.00*	0.00~150.00	Hz	5-3
B01.11	Frequency Reference 11	0.00*	0.00~150.00	Hz	5-3
B01.12	Frequency Reference 12	0.00*	0.00~150.00	Hz	5-3
B01.13	Frequency Reference 13	0.00*	0.00~150.00	Hz	5-3
B01.14	Frequency Reference 14	0.00*	0.00~150.00	Hz	5-3
B01.15	Frequency Reference 15	0.00*	0.00~150.00	Hz	5-3
B01.16	Frequency Reference 16	0.00*	0.00~150.00	Hz	5-3
B01.17	Jog Reference	6.00*	0.00~150.00	Hz	5-3

\* Parameters defaults changed by X-Press Programming

\*\* Parameters changed by E01.03

\*\*\* Value depends on drive model

\*\*\*\* Default value depends on control method

<b>Parameter</b>	<b>Parameter Name</b>	<b>Default</b>	<b>Range</b>	<b>Units</b>	<b>Reference Page</b>
B01.18	Reference Priority 00: Digital Reference Only 01: Analog Reference Only 02: Higher Reference Select	00*	00–02	--	5-3
B02.01	Frequency Reference Upper Limit	100.0	0.0–110.0	%	5-5
B02.02	Frequency Reference Lower Limit	0.0	0.0–110.0	%	5-5
B02.03	Reference 1 Lower Limit	2.0*	0.0–110.0	%	5-5
B02.04	Alt Upper Limit	100.0	0.0–110.0	%	5-5
B03.01	Reference Source 00: Digital Operator 01: Terminal 02: Communication 04: Pulse Input	01	00–02, 04	--	5-6
B03.02	Run Source 00: Digital Operator 01: Terminal Block 02: Communication 03: Not Used 04: Not Used	01	00–04	--	5-6
B03.03	Stop Method 00: Decel to Stop 01: Coast to Stop 02: DC Injection Braking 04: Decel with Timer	01*	00–02, 04	--	5-6
B03.04	Change Motor Rotation 00: Normal Rotation 01: Exchange Phases	00	00–01	--	5-12
B03.07	Local/Remote 00: Cycle External Run 01: Accept External Run	00	00–01	--	5-13
B03.10	Allow Run at Power UP 00: Disabled 01: Enabled	00	00–01	--	5-13
B03.15	Reference Selection 00: Operator 01: Terminal Block 02: Communication 03: Not Used 04: Pulse Input	01	00–04	--	5-13
B03.16	Reference Source 00: Operator 01: Terminal Block 02: Communication 03: Not Used	01	00–03	--	5-13
B05.01	Accel Time 1	5.0*	0.0–25.5	sec	5-14
B05.02	Decel Time 1	3.0*	0.0–25.5	sec	5-14
B05.03	Accel Time 2	2.0	0.0–6000.0	sec	5-14
B05.04	Decel Time 2	2.0	0.0–6000.0	sec	5-14
B05.05	Accel Time N Change	2.0	0.0–25.5	sec	5-14
B05.06	Decel Time N Change	2.0	0.0–25.5	sec	5-14
B05.08	Fast Stop Time	1.0	0.0–25.5	sec	5-14

\* Parameters defaults changed by X-Press Programming

\*\* Parameters changed by E01.03

\*\*\* Value depends on drive model

\*\*\*\* Default value depends on control method

Parameter	Parameter Name	Default	Range	Units	Reference Page
B05.09	Accel/Decel Units 00: Unit of 0.01 Seconds 01: Unit of 0.1 Seconds	01	00–01	--	5-14
B05.10	Accel/Decel Switch Frequency	120.0	0.0–150.0	Hz	5-14
B05.11	Switch Frequency Compare 00: Lower Switch Frequency 01: Upper Switch Frequency	01	00–01	--	5-14
B05.12	Accel Time 3	3.0	0.0–6000.0	sec	5-14
B05.13	Decel Time 3	3.0	0.0–6000.0	sec	5-14
B05.14	Accel Time 4	3.0	0.0–6000.0	sec	5-14
B05.15	Decel Time 4	3.0	0.0–6000.0	sec	5-14
B08.01	Jump Frequency 1	0.0	0.0–150.0	Hz	5-15
B08.02	Jump Frequency 2	0.0	0.0–150.0	Hz	5-15
B08.03	Jump Frequency 3	0.0	0.0–150.0	Hz	5-15
B08.04	Jump Frequency Width	1.0	0.0–20.0	Hz	5-15
C01.01	Quick Stop 00: Disabled 01: Enabled	00*	00, 01	--	5-17
C01.02	Quick Stop Time	1.0	0.0–25.5	sec	5-17
C01.03	Reverse Plug 00: Disabled 01: Enabled	00	00, 01	--	5-18
C01.04	Reverse Plug Decel Time	2.0	0.0–25.5	sec	5-18
C01.05	Reverse Plug Accel Time	2.0	0.0–25.5	sec	5-18
C02.01	MicroSpd Gain 1	1.00	0.00–2.55	--	5-19
C02.02	MicroSpd Gain 2	1.00	0.00–2.55	--	5-19
C03.01	Upper Limit 1 (UL1) Speed	6.00	0.00–150.00	Hz	5-20
C03.02	Upper Limit 1 (UL1) Decel Time	1.0	0.0–25.5	sec	5-20
C03.03	Upper Limit 2 (UL2) Decel Time	1.0	0.0–25.5	sec	5-20
C03.04	Lower Limit 1 (LL1) Speed	6.00	0.00–150.00	Hz	5-20
C03.05	Lower Limit 1 (LL1) Decel Time	1.0	0.0–25.5	sec	5-20
C03.06	Lower Limit 2 (LL2) Decel Time	1.0	0.0–25.5	sec	5-20
C03.07	Limit Action @ LL2/UL2 00: Decel to Stop 01: Coast to Stop 02: Use B03.03 Stopping Method	02*	00–02	--	5-20
C03.08	Limit Action @ UL3 00: Decel to Stop/Alarm 01: Coast to Stop/Alarm 02: Use B03.03 Stopping Method/Alarm 03: Decel/Fault 04: Coast/Fault 05: Use B03.03 Stopping Method/Fault	04	00–05	--	5-20
C03.09	Phantom Stop Selection 00: Decel to Stop 01: Coast to Stop 02: Use B03.03 Stopping Method	01	00–02	--	5-21

\* Parameters defaults changed by X-Press Programming

\*\* Parameters changed by E01.03

\*\*\* Value depends on drive model

\*\*\*\* Default value depends on control method

<b>Parameter</b>	<b>Parameter Name</b>	<b>Default</b>	<b>Range</b>	<b>Units</b>	<b>Reference Page</b>
C03.11	Klixon Action 00: Decel to Stop 01: Lower Only	00	00–01	--	5-21
C05.01	Load Check 00: Disable 01: Enable Load Check 03: Enable Load Check Continuous 09: Load Check Set Up	00	00, 01, 03, 09	--	5-23
C05.02	LC Alarm Action 00: Alarm Only 01: Decel to Stop 02: Coast to Stop 03: Fast Stop 04: Use B03.03 Stopping Method	04	00–04	--	5-23
C05.03	LC Setting Time	0.15	0.00–2.55	sec	5-23
C05.04	LC Testing Time	0.25	0.00–2.55	sec	5-23
C05.05	LC Acceleration Margin	05	00–50	--	5-23
C05.07	LC Margin	05	00–20	--	5-23
C05.08	LC Lowering Speed	6.0	0.1–30.0	Hz	5-23
C05.09	LC Zone 01	000	000–160	%	5-23
C05.10	LC Zone 02	000	000–160	%	5-23
C05.11	LC Zone 03	000	000–160	%	5-23
C05.12	LC Zone 04	000	000–160	%	5-23
C05.13	LC Zone 05	000	000–160	%	5-23
C05.14	LC Zone 06	000	000–160	%	5-23
C05.15	LC Zone 07	000	000–160	%	5-23
C05.16	LC Zone 08	000	000–160	%	5-23
C05.17	LC Zone 09	000	000–160	%	5-23
C05.18	LC Zone 10	000	000–160	%	5-23
C05.19	LC Zone 11	000	000–160	%	5-23
C05.20	LC Zone 12	000	000–160	%	5-23
C05.21	LC Zone 13	000	000–160	%	5-24
C05.22	LC Zone 14	000	000–160	%	5-24
C05.23	LC Zone 15	000	000–160	%	5-24
C05.24	LC Zone 16	000	000–160	%	5-24
C05.25	LC Integral Time	0.05	0.00–2.55	sec	5-24
C05.26	LC Delay Time	0.25	0.00–2.55	sec	5-24
C05.27	LC Rev Dir Delay	0.0	0.0–25.5	sec	5-24
C05.28	LC Rev Dir Freq	30.0	0.0–60.0	Hz	5-24
C06.01	Swift-Lift 00: Disabled 01: Enabled Automatic 02: Enabled by MFI 13	00	00–02	--	5-25
C06.02	Swift-Lift Forward Speed	60.00	0.00–150.00	Hz	5-25
C06.03	Swift-Lift Reverse Speed	60.00	0.00–150.00	Hz	5-25

\* Parameters defaults changed by X-Press Programming

\*\* Parameters changed by E01.03

\*\*\* Value depends on drive model

\*\*\*\* Default value depends on control method

<b>Parameter</b>	<b>Parameter Name</b>	<b>Default</b>	<b>Range</b>	<b>Units</b>	<b>Reference Page</b>
C06.04	Swift-Lift Forward Torque	50	0–100	%	5-25
C06.05	Swift-Lift Reverse Torque	30	0–100	%	5-25
C06.06	Swift-Lift Enabling Speed	59.00	0.00–150.00	Hz	5-25
C06.07	Swift-Lift Delay Time	2.0	0.0–25.5	sec	5-25
C06.08	Swift-Lift Acceleration Gain	1.0	0.1–9.9	--	5-25
C07.01	Forward Torque Limit	150	000–300	%	5-29
C07.02	Reverse Torque Limit	150	000–300	%	5-29
C07.03	Forward Regen Torque Limit	180	000–300	%	5-29
C07.04	Reverse Regen Torque Limit	180	000–300	%	5-29
C07.05	Torque Limit Gain	1.25	0.00–2.55	--	5-29
C07.06	Torque Limit Time Constant	00200	5–10000	ms	5-29
C07.07	Torque Limit Select 00: P Control 01: P1 Control	00	00–01	--	5-29
C08.04	Rollback Timer	0.30	0.00–2.55	sec	5-30
C08.11	Brake Set Delay	0.7	0.0–25.5	sec	5-30
C08.17	BE6 Up Speed Limit	6.00	0.00–150.00	Hz	5-30
C12.01	Brake Jog Delay	0.0	0.0–100.0	sec	5-31
C12.02	Brake Run Delay	0.0	0.0–100.0	sec	5-31
C12.03	Delay-on timer	0.0	0.0–3000.0	sec	5-31
C12.04	Delay-off timer	0.0	0.0–3000.0	sec	5-31
C12.05	Maintenance Timer	00000	0000–32767	hr	5-32
C12.06	Maintenance Speed Gain	0.5	0.0–1.0	--	5-32
C13.01	Inch Run Time	1.00	0.00–2.55	sec	5-33
C13.02	Repeat Delay Time	1.00	0.00–2.55	sec	5-33
D01.01	DC Injection Start Frequency	0.5	0.0–10.0	Hz	5-34
D01.02	DC Injection Current	50	0–75	%	5-34
D01.03	DC Injection Time @ Start	0.00	0.00–10.00	sec	5-34
D01.04	DC Injection Time @ Stop	0.05	0.00–10.00	sec	5-34
D01.08	Magnetic Flux Compensation	0000	0000–1000	%	5-35
D01.15	DC Injection Braking Current 2	050	000–100	%	5-35
D02.01	Slip Compensation Gain	0.0****	0.0–2.5	--	5-36
D02.02	Slip Compensation Time	200***	0–10000	ms	5-36
D02.03	Slip Compensation Limit	200	0–250	%	5-36
D02.04	Slip Compensation Regen 00: Disabled 01: Enabled	00	00–01	--	5-36
D02.05	Slip Compensation V/f 00: Disable 01: Enable	00	00–01	--	5-36

\* Parameters defaults changed by X-Press Programming

\*\* Parameters changed by E01.03

\*\*\* Value depends on drive model

\*\*\*\* Default value depends on control method

Parameter	Parameter Name	Default	Range	Units	Reference Page
D02.06	Magnetic Flux Characteristic 00: Slip Include 01: Slip Exclude	00	00–01	--	5-36
D03.01	Torque Compensation Gain	1.00	0.00–2.50	--	5-37
D03.02	Torque Compensation Time	200****	0–60000	ms	5-37
D03.03	Forward Torque Compensation @ Start	0.0	0.0–200.0	%	5-37
D03.04	Reverse Torque Compensation @ Start	0.0	-200.0–0.0	%	5-37
D03.05	Torque Compensation Delay Time	10	0–200	ms	5-37
D03.06	Torque Compensation Delay Time 2	150	0–10000	ms	5-37
D08.01	Dwell Reference @ Start	0.0	0.0–150.0	Hz	5-38
D08.02	Dwell Time @ Start	0.0	0.0–10.0	sec	5-38
D08.03	Dwell Reference @ Stop	0.0	0.0–150.0	Hz	5-38
D08.04	Dwell Time @ Stop	0.0	0.0–10.0	sec	5-38
D09.01	S-Curve Accel @ Start	0.50*	0.00–10.00	sec	5-39
D09.02	S-Curve Accel @ End	0.50*	0.00–10.00	sec	5-39
D09.03	S-Curve Decel @ Start	0.50*	0.00–10.00	sec	5-39
D09.04	S-Curve Decel @ Stop	0.20	0.00–10.00	sec	5-39
D10.01	CT/VT Selection 00: Heavy Duty 01: Normal Duty	00	00–01	--	5-40
D10.02	Carrier Frequency Selection 01: 2.0 kHz 02: 5.0 kHz 03: 8.0 kHz 04: 10.0 kHz 05: 12.5 kHz 06: 15.0 kHz 07: Swing PWM1 08: Swing PWM2 09: Swing PWM3 0A: Swing PWM4 0F: Custom (determined by the settings of D10.03~D10.06)	01	01–0F	--	5-40
D10.03	Carrier Frequency Upper Limit	2.0	1.0–15.0	kHz	5-40
D10.04	Carrier Frequency Lower Limit	2.0	1.0–15.0	kHz	5-40
D10.05	Carrier Frequency Gain	00	00–99	--	5-40
D11.01	Hunting Prevention Selection 00: Disabled 01: Enabled	01	00–01	--	5-41
D11.02	Hunting Prevention Gain	1.00	0.00–2.50	--	5-41
D11.03	Hunting Prevention Time Constant	10	0–500	ms	5-41
D11.05	Hunting Prevention Gain in Reverse	0.00	0.0–2.50	--	5-41
E01.01	Input Voltage	***	155–255 310–510	V	5-42
E01.03	V/f selection	04*	00–FF	--	5-43
E01.04	Max Frequency	**	0.00–150.00	Hz	5-43

\* Parameters defaults changed by X-Press Programming

\*\* Parameters changed by E01.03

\*\*\* Value depends on drive model

\*\*\*\* Default value depends on control method

Parameter	Parameter Name	Default	Range	Units	Reference Page
E01.05	Max Voltage	**	0.0–255.0 0.0–510.0	V	5-43
E01.06	Base Frequency	**	0.00–150.00	Hz	5-43
E01.07	Mid Frequency A	**	0.00–150.00	Hz	5-43
E01.08	Mid Voltage A	**	0.0–255.0 0.0–510.0	V	5-43
E01.09	Min Frequency	**	0.00–150.00	Hz	5-43
E01.10	Min Voltage	**	0.0–255.0 0.0–510.0	V	5-43
E01.11	Mid Frequency B	**	0.00–150.00	Hz	5-43
E01.12	Mid Voltage B	**	0.0–255.0 0.0–510.0	V	5-43
E01.13	Base Voltage	**	0.0–255.0 0.0–510.0	V	5-43
E02.01	Motor Rated FLA	--	0.0–70.0	A	5-45
E02.02	Motor Rated Slip	--	0.00–20.00	Hz	5-45
E02.03	No-Load Current	--	0.0–70.0	A	5-45
E02.04	Number of Poles	04	02–48	--	5-45
E02.05	Terminal Resistance	--	0.000–65.000	Ω	5-45
E02.06	Leakage Inductance	--	0.0–40.0	%	5-45
E02.07	Saturation Comp 1	--	0.00–0.50	--	5-45
E02.08	Saturation Comp 2	--	0.00–0.75	--	5-45
E02.09	Motor Mechanical Loss	0.0	0.0–10.0	%	5-45
E02.10	Motor Iron Loss of Torque Compensation	--	0–65535	W	5-45
E02.11	Motor Rated Power	--	0.0–20.0	HP	5-45
E02.12	Saturation Comp 2	--	1.30–5.00	%	5-45
F01.02	Pulse Feedback Loss 00: Decel to Stop (by B05.02) 01: Coast to Stop 02: Fast Stop (by B05.08) 03: Alarm Only	01	00–03	--	5-46
F01.03	Operation at Overspeed 00: Decel to Stop (by B05.02) 01: Coast to Stop 02: Fast Stop (by B05.08) 03: Alarm only	01	00–03	--	5-46
F01.04	Operation at Deviation: 00: @ speed agree - Decel (by B05.02) 01: @ speed agree - Coast to Stop 02: @ speed agree - Fast Stop (by B05.08) 03: @ speed agree - alarm only 04: @ run - Decel to Stop (by B05.02) 05: @ run - Coast to Stop 06: @ run - Fast Stop (by B05.08) 07: @ run - Alarm Only (Dev-1 and Dev-2 Alarm)	05	00–07	--	5-46
F01.08	Overspeed Detection Level	105	00–120	%	5-46

\* Parameters defaults changed by X-Press Programming

\*\* Parameters changed by E01.03

\*\*\* Value depends on drive model

\*\*\*\* Default value depends on control method

<b>Parameter</b>	<b>Parameter Name</b>	<b>Default</b>	<b>Range</b>	<b>Units</b>	<b>Reference Page</b>
F01.09	Overspeed Detection Time	0.0	0.0–2.0	sec	5-46
F01.10	Excessive Speed Detection Level	10	00–50	%	5-46
F01.11	Excessive Speed Detection Time	0.3	0.0–10.0	sec	5-46
F01.14	PGO Detection Time	0.5	0.0–10.0	sec	5-46

\* Parameters defaults changed by X-Press Programming

\*\* Parameters changed by E01.03

\*\*\* Value depends on drive model

\*\*\*\* Default value depends on control method



Parameter	Parameter Name	Default	Range	Units	Reference Page
H01.01	Input Terminal 1 Select (See reference page for further details)	80*	00–81	--	5-47
	00: Multi-Step Reference 2				
	01: Multi-Step Reference 3				
	02: Multi-Step Reference 4				
	03: Multi-Step Reference 5				
	04: Speed Hold 2				
	05: Accel Command				
	06: Upper Limit 1 N.O.				
	07: Upper Limit 2 N.O.				
	08: Lower Limit 1 N.O.				
	09: Lower Limit 2 N.O.				
	0A: Upper Limit 1 N.C.				
	0B: Upper Limit 2 N.C.				
	0C: Lower Limit 1 N.C.				
	0D: Lower Limit 2 N.C.				
	0E: M-Speed Gain 1				
	0F: Not Used				
	10: M-Speed Gain 2				
	12: Weight Limit N.C.				
	13: Swift-Lift				
	14: Alternate Torque Limit Gain				
	15: Forward Jog				
	16: Reverse Jog				
	17: Forward Inch				
	18: Reverse Inch				
	19: Inch Repeat				
	1A: Acc/Dec 2				
	1B: Acc/Dec 3				
	1C: Acc/Dec 4				
	1D: Digital Changeover				
	1F: Option/Inverter Switch				
	20–2F: External Fault				
	30: Program Lockout				
	31: Local/Remote Switch				
	32: Ext BB N.O.				
	33: Ext BB N.C.				
	39: External OH2				
	3A: Terminal A1/A2 Enable				
	3F: Fault Reset				
	40: Fast Stop N.O.				
	42: Fast Stop N.C.				
	43: Timer Enable				
	47: Analog Hold				
	4C: DC Injection Braking				
	53: Communication Test				
	55: Drive Enable				
	56: Klixon N.O.				
	57: Klixon N.C.				
	58: Brake Answerback				
	59: Alternate Upper Frequency Limit				
	5A: Maintenance Reset				
	5B: BE6 Up Speed Limit				
	5F: Phantom Stop N.C.				
	62: Weight Limit N.O.				
	63: Phantom Stop N.O.				
	65: Dwell Enable				
	69: LC Disable				
	70: Torque Detection Enable				
	80: Forward Run				
	81: Reverse Run				
H01.02	Terminal 2 Select (See reference page for further details)	81*	00–81	--	5-47

\* Parameters defaults changed by X-Press Programming

\*\* Parameters changed by E01.03

\*\*\* Value depends on drive model

\*\*\*\* Default value depends on control method

<b>Parameter</b>	<b>Parameter Name</b>	<b>Default</b>	<b>Range</b>	<b>Units</b>	<b>Reference Page</b>
H01.03	Terminal 3 Select (See reference page for further details)	00*	00–81	--	5-47
H01.04	Terminal 4 Select (See reference page for further details)	01*	00–81	--	5-47
H01.05	Terminal 5 Select (See reference page for further details)	0F*	00–81	--	5-47
H01.06	Terminal 6 Select (See reference page for further details)	0F*	00–81	--	5-47
H01.07	Terminal 7 Select (See reference page for further details)	0F*	00–81	--	5-47

\* Parameters defaults changed by X-Press Programming

\*\* Parameters changed by E01.03

\*\*\* Value depends on drive model

\*\*\*\* Default value depends on control method

Parameter	Parameter Name	Default	Range	Units	Reference Page
H02.01	Output Contact (MC-MB-MA) Select	000*	000-1FF	--	5-52
	000: Brake Release				
	001: Zero Speed				
	002: Fref, Fout Agree 1				
	003: Fref/Set Agree 1				
	004: Frequency Detect 1				
	005: Frequency Detect 2				
	006: Inverter Ready				
	007: DC Bus Undervolt				
	008: Base Block N.O.				
	009: Operator Reference				
	00A: Local Operation				
	00B: Torque Detect 1 N.O.				
	00D: DB Overheat				
	00E: Fault				
	00F: Not used				
	010: Minor Fault				
	011: Reset Command Active				
	012: Timer Output				
	013: Freq/Fout Agree 2				
	014: Freq/Set Agree 2				
	015: Frequency Detect 3				
	016: Frequency Detect 4				
	017: Torque Detect 1 N.C				
	018: Torque Detect 2 N.O.				
	019: Torque Detect 2 N.C.				
	01A: Forward Direction				
	01B: Reverse Direction				
	01C: Swift-Lift Active				
	01D: Base Block N.C.				
	020: Auto-Reset				
	021: Overload OL1				
	022: Overhead Pre-Alarm				
	023: Torque Limit				
	026: Run Command is Input				
	027: Load Check Detect				
	029: Upper Limit				
	02A: During Run 1				
	02B: During Fast Stop				
	02F: Load Weakening				
	030: Lower Limit				
	031: Upper/Lower Limit				
	035: Load Check Fault Detection				
	037: Maintenance				
	039: Drive Enable				
	03A: Overheat Pre-Alarm Time Limit				
	03D: During Speed Search				
	03F: Klixon				
	040~0FF: Fault Annunciate				
	101: (Inverse) Zero Speed				
	102: (Inverse) Fref/Fout Agree 1				
	103: (Inverse) Fref/Set Agree 1				
	104: (Inverse) Frequency Detect 1				
	105: (Inverse) Frequency Detect 2				
	106: (Inverse) Inverter Ready				
	107: (Inverse) DC Bus Undervolt				
	108: (Inverse) Base Block N.O.				
	109: (Inverse) Operator Reference				
	10A: (Inverse) Local Operation				
	10B: (Inverse) Torque Detect 1 N.O.				
	10D: (Inverse) DB Overheat				
	10E: (Inverse) Fault				
	110: (Inverse) Minor Fault				
	111: (Inverse) Reset Command Active				
	112: (Inverse) Timer Output				
	113: (Inverse) Freq Agree 2				

\* Parameters defaults changed by X-Press Programming

\*\* Parameters changed by E01.03

\*\*\* Value depends on drive model

\*\*\*\* Default value depends on control method

Parameter	Parameter Name	Default	Range	Units	Reference Page
	114: (Inverse) Freq Set 2				
	115: (Inverse) Frequency Detect 3				
	117: (Inverse) Torque Detect 1 N.C.				
	118: (Inverse) Torque Detect 2 N.O.				
	119: (Inverse) Torque Detect 2 N.C.				
	11A: (Inverse) Forward Direction				
	11B: (Inverse) Reverse Direction				
	11C: (Inverse) Swift-Lift Active				
	11D: (Inverse) Base Block N.C.				
	120: (Inverse) Auto-Reset				
	121: (Inverse) Overload OL1				
	122: (Inverse) Overheat Pre-Alarm				
	123: (Inverse) Torque Limit				
	126: (Inverse) Run Command is input				
	127: (Inverse) Load Check Detect				
	129: (Inverse) Upper Limit				
	12A: (Inverse) During Run 1				
	12B: (Inverse) During Fast Stop				
	12F: (Inverse) Load Weakening				
	130: (Inverse) Lower Limit				
	131: (Inverse) Upper/Lower Limit				
	135: (Inverse) Load Check Fault Detection				
	137: (Inverse) Maintenance				
	139: (Inverse) Drive Enable				
	13A: (Inverse) Overheat Pre-Alarm Time Limit				
	13D: (Inverse) During Speed Search				
	13F: (Inverse) Klixon				
	140~1FF: (Inverse) Fault Annunciate				
H02.02	Output Terminal P1 Select (See H02.01 for selections)	00F*	000–1FF	--	5-52
H02.03	Output Terminal P2 Select (See H02.01 for selections)	00F*	000–1FF	--	5-52
H03.01	Terminal A1 Signal Select 00: 10 VDC	00*	00	--	5-56
H03.02	Terminal A1 Select 00: Frequency Bias 01: Frequency Gain 02: Aux Speed Reference 1 03: Aux Speed Reference 2 04: Output Voltage Bias 07: OT/UT Detection Level 0F: Not Used 10: Forward Torque Limit 11: Reverse Torque Limit 12: Regen Torque Limit 15: FWD/REV Torque Limit 1F: Not Used	00	00–1F	--	5-56
H03.03	Terminal A1 Gain	100.0	-999.9–999.9	%	5-56
H03.04	Terminal A1 Bias	0.0	-999.9–999.9	%	5-56
H03.09	Terminal A2 Signal Select 00: 0~10 VDC 02: 4 to 20 mA 03: 0 to 20 mA	02	00, 02, 03	--	5-57

\* Parameters defaults changed by X-Press Programming

\*\* Parameters changed by E01.03

\*\*\* Value depends on drive model

\*\*\*\* Default value depends on control method

<b>Parameter</b>	<b>Parameter Name</b>	<b>Default</b>	<b>Range</b>	<b>Units</b>	<b>Reference Page</b>
H03.10	Terminal A2 Select 00: Frequency Bias 01: Frequency Gain 02: Aux Speed Reference 1 03: Aux Speed Reference 2 04: Output Voltage Bias 07: OT/UT Detection Level 0F: Not Used 10: Forward Torque Limit 11: Reverse Torque Limit 12: Regen Torque Limit 15: FWD/REV Torque Limit 1F: Not Used	00	00–1F	--	5-57
H03.11	Terminal A2 Gain	100.0	-999.9–999.9	%	5-57
H03.12	Terminal A2 Bias	0.00	-999.9–999.9	%	5-57
H03.13	Analog Input Filter Time Constant	0.03	0.00–2.00	sec	5-57
H04.01	Terminal AM Select 101: Frequency Reference 102: Output Frequency 103: Output Current 105: Motor Speed (OLV Only) 106: Output Voltage 107: DC Bus Voltage 108: Output Power (Calculated kWatts) 109: Torque Reference (OLV Only) 115: Terminal A1 Level 116: Terminal A2 Level 120: SFS Output 154: Input Pulse Monitor 162: Not Used	102	101–162	--	5-58
H04.02	Terminal AM Gain	100.0	-999.9–999.9	%	5-58
H04.03	Terminal AM Bias	0.0	-999.9–999.9	%	5-58
H05.01	Serial Comm Address	1F	00–20	--	5-59
H05.02	Series Baud Rate 00: 1200 BPS 01: 2400 BPS 02: 4800 BPS 03: 9600 BPS 04: 19200 BPS 05: 38400 BPS 06: 57600 BPS 07: 76800 BPS 08: 115200 BPS	03	00–08	--	5-59
H05.03	Communications - Parity 00: No Parity 01: Even Parity 02: Odd Parity	00	00–02	--	5-59
H05.04	Communication - Error Stopping Method 00: Decel to Stop 01: Coast to Stop 02: Fast-Stop 03: Alarm Only 04: Use B03.03	04	00–04	--	5-59
H05.05	Communication - Error Detection Select 00: Disable 01: Enable	01	00–01	--	5-59
H05.06	Transmit Wait Time	05	05–65	ms	5-59

\* Parameters defaults changed by X-Press Programming

\*\* Parameters changed by E01.03

\*\*\* Value depends on drive model

\*\*\*\* Default value depends on control method

<b>Parameter</b>	<b>Parameter Name</b>	<b>Default</b>	<b>Range</b>	<b>Units</b>	<b>Reference Page</b>
H05.07	RTS Control Select 00: Disable 01: Enable	01	00–01	--	5-59
H05.09	Communication - Error Detection Time	2.0	0.0–10.0	sec	5-59
H05.10	Output Voltage Reference 00: 0.1V 01: 1V	00	00–01	--	5-59
H05.11	Communication Enter Function Select 00: Enter Command must be used (G+Series 2/3 Method) 01: Enter Command Not Required (P3S2 Method)	00	00–01	--	5-60
H05.12	Run Command Method Selection 00: Bit 0 = Start/Stop Forward Direction Bit 1 = Start/Stop Reverse Direction 01: Bit 0 = Start/Stop Bit 1 = Forward/Reverse Direction	00	00–01	--	5-60
H06.01	Pulse Input Selection 00: Frequency Reference 03: Encoder Feedback	00	00, 03	--	5-61
H06.02	Pulse Input Scaling	1440	1000–32,000	Hz	5-61
H06.03	Pulse Input Gain	100.0	0.0–1000.0	%	5-61
H06.04	Pulse Input Bias	0.0	-100.0–100.0	%	5-61
H06.05	Pulse Input Filter Time	0.10	0.00–2.00	sec	5-61
H06.06	Pulse Monitor Selection	102	000, 031, 101, 102, 105, 120, 501, 502	--	5-61
H06.07	Pulse Monitor Scaling	1400	0–32,000	Hz	5-61
L01.01	Motor Overload Fault Select 00: Disabled 01: Standard Fan Cooled 02: Standard Blower Cooled 03: Vector Motor	03	00–03	--	5-63
L01.02	Motor Overload Time Constant	1.0	0.1–5.0	min	5-63
L01.03	Motor Overheat Alarm Selection 00: Decel to Stop (Alarm) 01: Coast to Stop (Alarm) 02: Fast-Stop by B05.08 (Alarm) 03: Alarm Only (OH3 Flashes) 04: Stop by B03.03 Stopping Method (Alarm)	03	00–04	--	5-63
L01.04	Motor Overheat Fault Selection 00: Decel to Stop 01: Coast to Stop 02: Fast-Stop by B05.08 (Alarm) 03: Stop by B03.03 Stopping Method (Alarm)	03	00–03	--	5-63
L01.05	Motor Temp Filter	0.20	0.00–10.00	sec	5-63
L01.13	Overhead Operation Selection 00: Disable 01: Enable	01	00–01	--	5-63

\* Parameters defaults changed by X-Press Programming

\*\* Parameters changed by E01.03

\*\*\* Value depends on drive model

\*\*\*\* Default value depends on control method

Parameter	Parameter Name	Default	Range	Units	Reference Page
L02.01	Power-loss Selection 00: Disable 01: Enabled 02: CPU Power Active	00	00–02	--	5-64
L02.02	Power-loss Ride Thru Time	0.1 (Varies)	0.0–25.5	sec	5-64
L02.03	Power-loss Base Block Time	01. (Varies)	0.1–5.0	sec	5-64
L02.04	Power-loss V/f Ramp Time	0.3 (Varies)	0.0–5.0	sec	5-64
L02.05	PUV Detection Level	190/380	150–210 300–420	V	5-64
L02.07	Power-loss Ride Thru Accel	0.0	0.0–25.5	sec	5-64
L03.01	Stall Prevention Accel Select 00: Disabled 01: General Purpose 02: Intelligent	01	00–02	--	5-65
L03.02	Stall Prevention Accel Level	150	0–150	%	5-65
L03.03	Stall Prevention Constant HP Limit	50	0–100	%	5-67
L03.05	Stall Prevention Run Select 00: Disabled 01: Decel Time 1 02: Decel Time 2	01	00–02	--	5-68
L03.06	Stall Prevention Run Level	150	30–150	%	5-69
L03.17	DC Bus Voltage for Intelligent Control	370	150–400	V	5-70
L03.20	Main Circuit Voltage Gain	A01.02	0.00–5.00	--	--
L03.21	Deceleration Calculation Gain	A01.02	0.00–200.00	--	--
L03.23	Automatic Stall Prevention Selection During Run 00: Sets the level to L03.04 throughout the entire frequency range 01: Automatically lowers Stall Prevention level during run in the constant power range. The lower limit will be 40% of L03.06.	00	00–01	--	5-70
L03.24	Motor Acceleration Time Inertial Calculations	O02.04	0.001–10.000	--	5-70
L03.25	Load Inertia Ratio	1.0	0.0–1000.0	--	5-70
L04.01	Speed Agree Level ±	0.0	0.0–150.0	Hz	5-71
L04.02	Speed Agree Width ±	2.0	0.0–20.0	Hz	5-71
L04.03	Speed Agree Level ±	0.0	-150.0–150.0	Hz	5-71
L04.04	Speed Agree Width ±	2.0	0.0–20.0	Hz	5-71
L04.07	Speed Agree Detection 00: No detection during baseblock 01: Detection always enabled	00	00, 01	--	5-72

\* Parameters defaults changed by X-Press Programming

\*\* Parameters changed by E01.03

\*\*\* Value depends on drive model

\*\*\*\* Default value depends on control method

Parameter	Parameter Name	Default	Range	Units	Reference Page
L06.01	Torque Detection 1 Level Select 00: Disabled 01: Overtorque @ Speed Agree (Alarm) 02: Overtorque @ Run (Alarm) 03: Overtorque @ Speed Agree (Fault) 04: Overtorque @ Run (Fault) 05: Undertorque @ Speed Agree (Alarm) 06: Undertorque @ Run (Alarm) 07: Undertorque @ Speed Agree (Fault) 08: Undertorque @ Run (Fault)	00	00–08	--	5-73
L06.02	Torque Detection 1 Level	150	0–300	%	5-74
L06.03	Torque Detection 1 Time	0.1	0.0–10.0	sec	5-74
L06.04	Torque Detection 2 Level Select 00: Disabled 01: Overtorque @ Speed Agree (Alarm) 02: Overtorque @ Run (Alarm) 03: Overtorque @ Speed Agree (Fault) 04: Overtorque @ Run (Fault) 05: Undertorque @ Speed Agree (Alarm) 06: Undertorque @ Run (Alarm) 07: Undertorque @ Speed Agree (Fault) 08: Undertorque @ Run (Fault)	00	00–08	--	5-74
L06.05	Torque Detection 2 Level	150	000–300	%	5-75
L06.06	Torque Detection 2 Time	0.1	0.0–10.0	sec	5-75
L06.08	Mechanical Weakening Detection Selection 00: Disabled 01: Speed (signed) > L06.09; Continue Running (Alarm) 02: Speed (unsigned) > L06.09; Continue Running (Alarm) 03: Speed (signed) > L06.09; Stop (Protection) 04: Speed (unsigned) > L06.09; Stop (Protection) 05: Speed (signed) < L06.09; Continue Running (Alarm) 06: Speed (unsigned) < L06.09; Continue Running (Alarm) 07: Speed (signed) < L06.09; Stop (Protection) 08: Speed (unsigned) < L06.09; Stop (Protection)	00	00–08	--	5-75
L06.09	Mechanical Weakening Detection Level	110.0	-110.0–110.0	%	5-75
L06.10	Mechanical Weakening Detection Time	0.1	0.0–10.0	sec	5-75
L06.11	Mechanical Weakening Start Time	0	0–65535	hrs	5-75
L08.02	Overheat Pre-Alarm Level	95	50–130	°C	5-76
L08.03	Overheat Pre-Alarm Selection 00: Decel to Stop 01: Coast to Stop 02: Fast Stop 03: Use B03.03 Stopping Method 04: Alarm Only 05: Derated Operation (L08.19)	05	00–05	--	5-76
L08.05	Input Phase Loss Selection 00: Disabled 01: Enabled	01	00–01	--	5-76

\* Parameters defaults changed by X-Press Programming

\*\* Parameters changed by E01.03

\*\*\* Value depends on drive model

\*\*\*\* Default value depends on control method



Parameter	Parameter Name	Default	Range	Units	Reference Page
L08.06	Input Phase Loss Detection Level (Increasing L08.06 from default value may cause DC BUS capacitor failure)	5.0	0.0–5.0	%	5-76
L08.07	Output Phase Loss Selection 00: Disabled 01: Enabled	01	00, 01	--	5-76
L08.08	Output Phase Loss Detection Level	5.0	0.0–20.0	%	5-76
L08.09	Ground Fault 00: Disable 01: Enable	01***	00, 01	--	5-76
L08.10	Fan Operation Selection 00: Fan On - Run with Time (L08.11) 01: Fan Always On	00	00, 01	--	5-76
L08.11	Fan Off-Delay Time	60	0–300	sec	5-76
L08.12	Ambient Temp	40	-10–50	°C	5-76
L08.15	OL2 Sel @ Low Speed 00: Disabled 01: Enabled	01	00, 01	--	5-76
L08.18	Soft CLA Sel 00: Disabled 01: Enabled	01	00, 01	--	5-77
L08.19	Overheat Pre-Alarm Frequency Reduction Rate	0.8	0.1, 0.9	%	5-77
L08.35	Mounting Selection 00: Disabled (standard installation) 01: Side-By-Side 02: NEMA 1 Standard 03: Finless	00	00–03	--	5-77
L08.41	High Current Alarm Selection 00: Disable 01: Enable	00	00, 01	--	5-77
L09.01	Auto Reset Select 00: Disable 01: Enable	01	00, 01	--	5-78
L09.02	Auto Reset Attempts	03	00–10	--	5-78
L09.03	Auto Reset Time	0.5	0.5–180.0	sec	5-78
L09.04	Auto Reset Fault Select 1	0001	0000–FFFF	--	5-78
L09.05	Auto Reset Fault Select 2	E000	0000–FFFF	--	5-78
L09.06	Output Contact (MC-MB-MA) Select 00: Disabled (No Fault Relay) 01: Enabled (Fault Relay Active)	01	00, 01	--	5-78
N02.01	AFR Tuning	1.00	0.00–10.00	--	5-81
N02.02	AFR Detection Time	50	0–2000	ms	5-81
N02.03	AFR Time Constant	750	0–2000	ms	5-81
N02.04	AFR Limit	5.0	0.0–60.0	Hz	5-81
N02.05	OLV Stabilization Level	00	00–11, FF	--	5-81
N06.01	Line-to-Line Motor Tuning 00: Disabled 01: Enabled	01	00–01	--	5-83

\* Parameters defaults changed by X-Press Programming

\*\* Parameters changed by E01.03

\*\*\* Value depends on drive model

\*\*\*\* Default value depends on control method

<b>Parameter</b>	<b>Parameter Name</b>	<b>Default</b>	<b>Range</b>	<b>Units</b>	<b>Reference Page</b>
001.01	User Montior Selection	106	104–638	--	5-84
	104: Control Method				
	105: Motor Speed - OLV ONLY				
	106: Output Voltage				
	107: DC Bus Voltage				
	108: Output Power				
	109: Torque Reference - OLV ONLY				
	110: Input Terminal Status				
	111: Output Terminal Status				
	112: Operation Status				
	113: Elapsed Time				
	114: FLASH ID				
	115: Terminal A1 Level				
	116: Terminal A2 Level				
	120: Output Frequency After Soft Start				
	128: CPU ID				
	134: OPE Detected				
	139: Memobus Comm Error Code				
	152: Maintenance Timer				
	154: Input Pulse Montior				
	162: Not Used				
	401: Cumulative Operation Time				
	403: Cooling Fan Operation Time				
	404: Cooling Fan Maintenance				
	405: Capacitor Maintenance				
	406: Soft Charge Bypass Relay Maintenance				
	407: IGBT Maintenance				
	408: Heatsink Temperature				
	410: kWh; Lower 4 Digits				
	411: kWh; Upper 5 Digits				
	412: CPU Resources Used				
	413: Peak Hold Current				
	414: Peak Hold Output Frequency				
	416: Motor Overload (oL1) Detection Level				
	417: Drive Overload (oL2) Detection Level				
	418: Frequency Reference Source Selection				
	419: Frequency Reference Memobus				
	420: Output Frequency Reference (decimal)				
	421: Run Command Selection Results				
	422: Memobus Communication Reference				
	423: Not Used				
	601: Motor Secondary Current (Iq)				
	602: Motor Excitation current (Id) - OLV ONLY				
	605: Output Voltage Reference (Vq) - OLV ONLY				
	606: Output Voltage Reference (Vd) - OLV ONLY				
	607: ACR (q) Output - OLV ONLY				
	608: ACR (d) Output - OLV ONLY				
	620: Frequency Reference Bias (Up/Down2)				
	621: Offset Frequency				
	636: Not Used				
	637: Not Used				
	638: Not Used				

\* Parameters defaults changed by X-Press Programming

\*\* Parameters changed by E01.03

\*\*\* Value depends on drive model

\*\*\*\* Default value depends on control method

Parameter	Parameter Name	Default	Range	Units	Reference Page
001.02	Power-On Monitor 01: Frequency Reference (U01.01) 02: Forward/Reverse 03: Output Frequency (U01.02) 04: Output current (U01.03) 05: User Monitor (O01.01)	03	01–05	--	5-86
001.03	Display Sealing 00: 0.01 Hz 01: 0.01% 02: r/min 03: User-set	00	00–03	--	5-86
001.10	User-set Display Maximum Units	06000	00000–60000	--	5-86
001.11	User-set Display Decimal 00: No Decimal Point 01: 0.1 02: 0.01 03: 0.001	02	00–03	--	5-86
002.01	Local/Remote Key 00: Disable 01: Enable	00	00, 01	--	5-86
002.02	Stop Key Operation 00: Coast to Stop 01: Decel to Stop 02: Use B03.03 Stopping Method	00	00–02	--	5-86
002.03	User Defaults 00: No Change 01: Set Defaults 02: Clear All	00	00–02	--	5-86
002.04	kVA Selection 60: Not Used 61: 2001-G+M 62: 2003-G+M 63: 2005-G+M 64: Not Used 65: 2008-G+M 66: 2011-G+M 67: Not Used 68: 2017-G+M 69: Not Used 6A: 2025-G+M 6B: 2033-G+M 6C: Not Used 6D: 2047-G+M 6E: 2060-G+M 91: 4001-G+M 92: 4002-G+M 93: 4003-G+M 94: 4004-G+M 95: 4005-G+MF (OEM Only) 96: 4007-G+MF (OEM Only) 97: 4009-G+M 98: Not Used 99: 4014-G+M 9A: 4018-G+M 9B: Not Used 9C: 4024-G+M 9D: 4031-G+M	--	60–90	--	5-86

\* Parameters defaults changed by X-Press Programming

\*\* Parameters changed by E01.03

\*\*\* Value depends on drive model

\*\*\*\* Default value depends on control method

<b>Parameter</b>	<b>Parameter Name</b>	<b>Default</b>	<b>Range</b>	<b>Units</b>	<b>Reference Page</b>
002.05	Operator M.O.P 00: Disabled 01: Enabled	00	00, 01	--	5-87
002.07	Motor Direction at power-up 00: Forward 01: Reverse	00	00, 01	--	5-87
003.01	Elapsed Time Setting	0000	0000–9999	hr	5-87
003.02	Elapsed Time Selection 00: Power On Time 01: Running Time	01	00, 01	--	5-87
003.03	Fan On Time	0000	0000–9999	hr	5-87
003.05	Capacitor Maintenance Time	000	000–150	%	5-87
003.07	Inrush Preventative Maintenance Relay Setting	000	000–150	%	5-88
003.09	IGBT Maintenance Setting	000	000–150	%	5-88
003.11	Fault Trace Clear 00: Not Cleared 01: Clear U2/U3	00	00, 01	--	5-88
003.12	kWh Monitor Initial Value Selection 00: Save 01: Reset	00	00, 01	--	5-88
003.14	Clear Count History 00: Not Clear 01: Clear AC Count 02: Clear OL/LC Count 03: Clear Both Counts	00	00–03	--	5-88
T01.01	Tuning Mode Select 00: Rotating Auto-Tune (OLV) 02: Stationary Auto-Tune 03: Rotating Auto-Tune (V/f)	02	00, 02, 03	--	4-20
T01.02	Motor Output Power	--	--	HP	4-20
T01.04	Motor Rated Current	--	--	A	4-20
T01.05	Base Frequency	60.00	0.00–150.00	Hz	
T01.06	Motor Poles	04	02–48	--	4-20
T01.07	Rated Speed	1750	0–24000	RPM	4-20
T01.11	Motor Iron Loss	--	--	W	4-20
U01.01	Frequency Reference	--	--	Hz	5-89
U01.02	Output Frequency	--	--	Hz	5-89
U01.03	Output Current	--	--	A	5-89
U01.04	Control Method	--	--	--	5-89
U01.05	Motor Speed (OLV Only)	--	--	Hz	5-89
U01.06	Output Voltage	--	--	V	5-89
U01.07	DC Bus Voltage	--	--	V	5-89
U01.08	Output Power	--	--	HP	5-89
U01.09	Motor Torque (OLV Only)	--	--	%	5-89
U01.10	Input Terminal Status	--	--	--	5-89

\* Parameters defaults changed by X-Press Programming

\*\* Parameters changed by E01.03

\*\*\* Value depends on drive model

\*\*\*\* Default value depends on control method

<b>Parameter</b>	<b>Parameter Name</b>	<b>Default</b>	<b>Range</b>	<b>Units</b>	<b>Reference Page</b>
U01.11	Output Terminal Status	--	--	--	5-89
U01.12	Inverter Control Status	--	--	--	5-90
U01.13	Elapsed Time	--	--	hours	5-90
U01.14	Flash ID	--	--	--	5-90
U01.15	Terminal A1 Level	--	--	%	5-90
U01.16	Terminal A2 Level	--	--	%	5-90
U01.20	Output Frequency after Soft Start	--	--	Hz	5-90
U01.28	Software CPU	--	--	--	5-90
U01.34	OPE Detection Parameter	--	--	Const #	5-90
U01.39	Memobus Communication Error	--	--	--	5-90
U01.52	Maintenance Timer	--	--	hours	5-90
U01.54	Pulse Monitor	--	--	Hz	5-90
U01.64	LC Zone	--	--	--	5-90
U01.65	LC Margin	--	--	%	5-90
U02.01	Current Fault	--	--	--	5-91
U02.02	Last Fault	--	--	--	5-91
U02.03	Frequency Reference @ Fault	--	--	Hz	5-91
U02.04	Output Frequency @ Fault	--	--	Hz	5-91
U02.05	Output Current @ Fault	--	--	A	5-91
U02.06	Motor Speed @ Fault (OLV Only)	--	--	Hz	5-91
U02.07	Output Voltage @ Fault	--	--	V	5-91
U02.08	DC Bus Voltage @ Fault	--	--	V	5-91
U02.09	Output Power @ Fault	--	--	kW	5-91
U02.10	Torque Reference @ Fault (OLV Only)	--	--	%	5-91
U02.11	Input Terminal Status @ Fault	--	--	--	5-91
U02.12	Output Terminal Status @ Fault	--	--	--	5-91
U02.13	Operation Status @ Fault	--	--	--	5-91
U02.14	Elapsed Operation Time @ Fault	--	--	hours	5-91
U02.15	Speed Reference During Soft Start	--	--	--	5-91
U02.16	Motor q-Axis Current During Fault	--	--	--	5-91
U02.17	Motor d-Axis Current During Fault	--	--	--	5-91
U03.01	Last Fault	--	--	--	5-91
U03.02	Fault Message 2	--	--	--	5-91
U03.03	Fault Message 3	--	--	--	5-91
U03.04	Fault Message 4	--	--	--	5-91
U03.05	Fault Message 5	--	--	--	5-91
U03.06	Fault Message 6	--	--	--	5-91
U03.07	Fault Message 7	--	--	--	5-91
U03.08	Fault Message 8	--	--	--	5-91

\* Parameters defaults changed by X-Press Programming

\*\* Parameters changed by E01.03

\*\*\* Value depends on drive model

\*\*\*\* Default value depends on control method

<b>Parameter</b>	<b>Parameter Name</b>	<b>Default</b>	<b>Range</b>	<b>Units</b>	<b>Reference Page</b>
U03.09	Fault Message 9	--	--	--	5-91
U03.10	Fault Message 10	--	--	--	5-91
U03.11	Elapsed Time 1	--	--	hours	5-91
U03.12	Elapsed Time 2	--	--	hours	5-91
U03.13	Elapsed Time 3	--	--	hours	5-91
U03.14	Elapsed Time 4	--	--	hours	5-91
U03.15	Elapsed Time 5	--	--	hours	5-91
U03.16	Elapsed Time 6	--	--	hours	5-91
U03.17	Elapsed Time 7	--	--	hours	5-91
U03.18	Elapsed Time 8	--	--	hours	5-91
U03.19	Elapsed Time 9	--	--	hours	5-91
U03.20	Elapsed Time 10	--	--	hours	5-91
U03.21	Accumulated Operations	--	--	--	5-92
U03.22	U03.21 Rollovers	--	--	--	5-92
U03.23	Overload/Load Check Count	--	--	--	5-92
U04.01	Cumulative Operation Time	--	--	hours	5-92
U04.03	Cooling Fan Operation Time	--	--	hours	5-92
U04.04	Cooling Fan Maintenance	--	--	%	5-92
U04.05	Capacitor Maintenance	--	--	%	5-92
U04.06	Soft Charge Bypass Relay Maintenance	--	--	%	5-92
U04.07	IGBT Maintenance	--	--	%	5-92
U04.08	Heatsink Temperature	--	--	°C	5-92
U04.10	kWh; Lower 4 Digits	--	--	kWh	5-92
U04.11	kWh; Upper 5 Digits	--	--	kWh	5-92
U04.12	CPU Resources Used	--	--	--	5-92
U04.13	Peak Hold Current	--	--	A	5-92
U04.14	Peak Hold Output Frequency	--	--	Hz	5-92
U04.16	Motor Overload (oL1) Detection Level	--	--	--	5-92
U04.17	Drive Overload (oL2) Detection Level	--	--	--	5-92
U04.18	Frequency Reference Source Selection	--	--	--	5-92
U04.19	Frequency Reference Memobus	--	--	--	5-92
U04.20	Output Frequency Reference (Decimal)	--	--	--	5-92
U04.21	Run Command Selection Results	--	--	--	5-92
U04.22	Memobus Communication Reference	--	--	--	5-92
U04.23	Not Used	--	--	--	5-92
U06.01	Motor Secondary Current (Iq)	--	--	%	5-92
U06.02	Motor Excitation Current (Id)	--	--	%	5-92
U06.03	ASR Input	--	--	%	5-92
U06.04	ASR Output	--	--	%	5-92

\* Parameters defaults changed by X-Press Programming

\*\* Parameters changed by E01.03

\*\*\* Value depends on drive model

\*\*\*\* Default value depends on control method

<b>Parameter</b>	<b>Parameter Name</b>	<b>Default</b>	<b>Range</b>	<b>Units</b>	<b>Reference Page</b>
U06.05	Output Voltage Reference (Vq)	--	--	V	5-93
U06.06	Output Voltage Reference (Vd)	--	--	V	5-93
U06.07	ACR (q) Output	--	--	%	5-93
U06.08	ACR (d) Output	--	--	%	5-93
U06.20	Frequency Reference Bias (Up/Down2)	--	--	%	5-93
U06.21	Offset Frequency	--	--	%	5-93
U06.36	GAIA Communication Error	--	--	--	5-93
U06.37	LUNA Communication Error	--	--	--	5-93
U06.38	Option Card Error	--	--	--	5-93

\* Parameters defaults changed by X-Press Programming

\*\* Parameters changed by E01.03

\*\*\* Value depends on drive model

\*\*\*\* Default value depends on control method

This page intentionally left blank.