

Electrobar Elite

Conductor Bar System

Instruction Manual



MAGNETEK
MATERIAL HANDLING
ELECTROMOTIVE SYSTEMS

ELITE-03A May 2013

Part Number: 005-1054 R4

© Copyright 2013 Electromotive Systems

Table of Contents

Preface and Safety	3
Product Safety Information	3
Product Warranty Information	3
DANGER, WARNING, CAUTION, and NOTE Statements	4
Electrobar Elite Assembly Instructions	5
Layout of Line Elements	6
Assembly of the Different Elements	7
1. Bracket	7
2. Sliding Hanger	8
3. Line Element	8
4. Expansion Joint	9
5. Fixed Hanger	10
6. Connection of Conductors	10
7. Joint Cover	12
8. Trolley	13
9. In-Line Feed Box	15
10. End-line feed box	20
11. End Cap	22
12. Connecting The Trolley	23
13. Tow Brackets	24
Cutting Line Elements On Site	25
20-130 A Instructions	25
200 A Instructions	27
Curved Applications	29
Before Assembly	29
Expansion Placement	29
Fixed Hanger Placement	29
Connecting Curved Elements	29
Assembly Procedure	30

Preface and Safety

©2013 MAGNETEK

All rights reserved. This notice applies to all copyrighted materials included with this product, including, but not limited to, this manual. This manual is intended for the sole use of the persons to whom it was provided, and any unauthorized distribution of the manual or dispersal of its contents is strictly forbidden. This manual may not be reproduced in whole or in part by any means whatsoever without the expressed written permission of Magnetek.

Product Safety Information

Magnetek, Inc. (Magnetek) offers a broad range of radio remote control products, control products and adjustable frequency drives, industrial braking systems, and power delivery products for material handling applications. This manual has been prepared by Magnetek to provide information and recommendations for the installation, use, operation and service of Magnetek's material handling products and systems (Magnetek Products). Anyone who uses, operates, maintains, services, installs or owns Magnetek Products should know, understand and follow the instructions and safety recommendations in this manual for Magnetek Products.

The recommendations in this manual do not take precedence over any of the following requirements relating to cranes, hoists, lifting devices or other equipment which use or include Magnetek Products:

- Instructions, manuals, and safety warnings of the manufacturers of the equipment where the Magnetek Products are used,
- Plant safety rules and procedures of the employers and the owners of the facilities where the Magnetek Products are being used,
- Regulations issued by the Occupational Health and Safety Administration (OSHA),
- The National Electrical Code (NEC),
- Applicable local, provincial, state or federal codes, ordinances, standards and requirements, or
- Safety standards and practices for the industries in which Magnetek Products are used.

This manual does not include or address the specific instructions and safety warnings of these manufacturers or any of the other requirements listed above. It is the responsibility of the owners, users and operators of the Magnetek Products to know, understand and follow all of these requirements. It is the responsibility of the employer to make its employees aware of all of the above listed requirements and to make certain that all operators are properly trained. **No one should use Magnetek Products prior to becoming familiar with and being trained in these requirements and the instructions and safety recommendations for this manual.**

Product Warranty Information

Magnetek, hereafter referred to as Company, assumes no responsibility for improper programming or operation of a device (such as a drive or radio) by untrained personnel. A device should only be programmed or operated by a trained technician who has read and understands the contents of the relevant manual(s). Improper programming or operation of a device can lead to unexpected, undesirable, or unsafe operation or performance of the device. This may result in damage to equipment or personal injury. Company shall not be liable for economic loss, property damage, or other consequential damages or physical injury sustained by the purchaser or by any third party as a result of such programming or operation. Company neither assumes nor authorizes any other person to assume for Company any other liability in connection with the sale or use of this product.

For information on Magnetek's product warranties by product type, please visit the Material Handling home page on www.magnetek.com.

DANGER, WARNING, CAUTION, and NOTE Statements

DANGER, WARNING, CAUTION, and NOTE statements are used throughout this manual to emphasize important and critical information. You must read these statements to help ensure safety and to prevent product damage. The statements are defined below.



DANGER

DANGER indicates an imminently hazardous situation which, if not avoided, will result in death or serious injury. This signal word is to be limited to the most extreme situations.



WARNING

WARNING indicates a potentially hazardous situation which, if not avoided, could result in death or serious injury.



CAUTION

CAUTION indicates a potentially hazardous situation which, if not avoided, could result in minor or moderate injury. It may also be used to alert against unsafe practices.

NOTE: A *NOTE* statement is used to notify people of installation, operation, programming, or maintenance information that is important, but not hazard-related.



WARNING

Many tests and procedures outlined in this manual involve exposure to components that operate at potentially lethal voltage levels. To eliminate this hazard, service personnel must ensure that the incoming three-phase AC power has been disconnected, locked out, and tagged.

Electrobar Elite Assembly Instructions

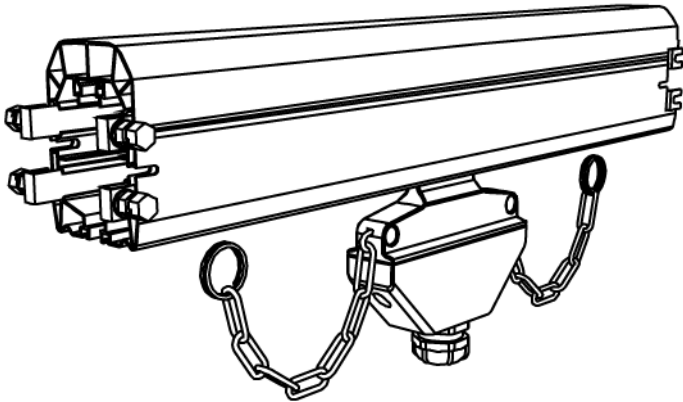

As we are continually striving to improve our products, we reserve the right to make any modifications without prior warning.

Layout of Line Elements

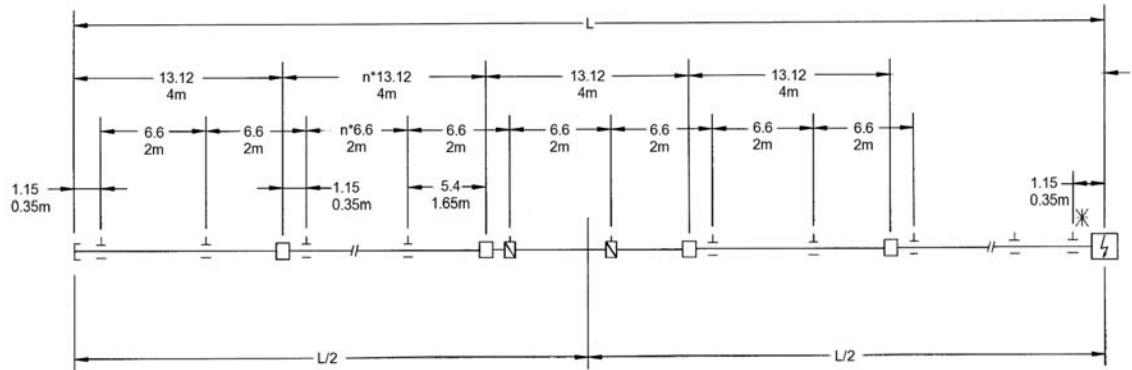

Figure 1: Line without expansion joint

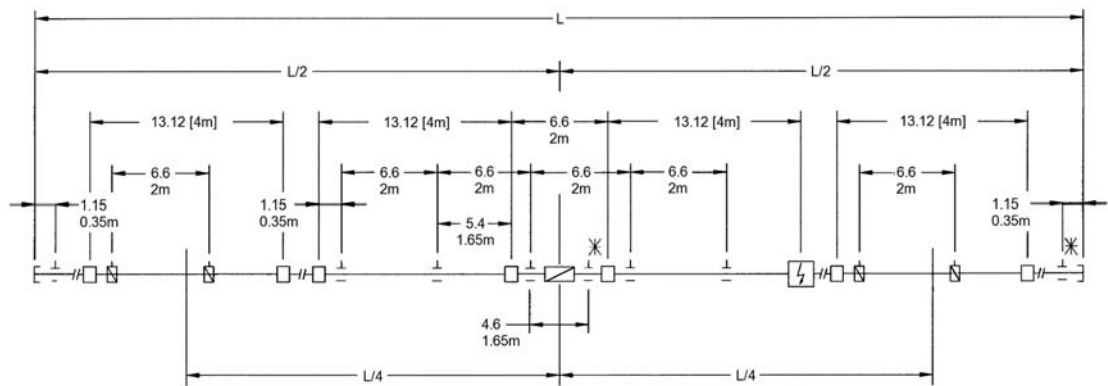

Figure 2: Line with expansion joint

Key:

- ▧ Fixed Hanger
- ⊥ Sliding Hanger
- Covering Flange
- ⚡ Feed Box
- ▧ Expansion Joint
- ⌈ End-cap
- ⊛ Additional Sliding Hanger

NOTE: The position of the feed boxes shown here is only an example. This position is determined by the calculation of the voltage drop and the running conditions.

Assembly of the Different Elements

1. Bracket



 14 N-m < M < 18 N-m

 125 - 160 in.lb.

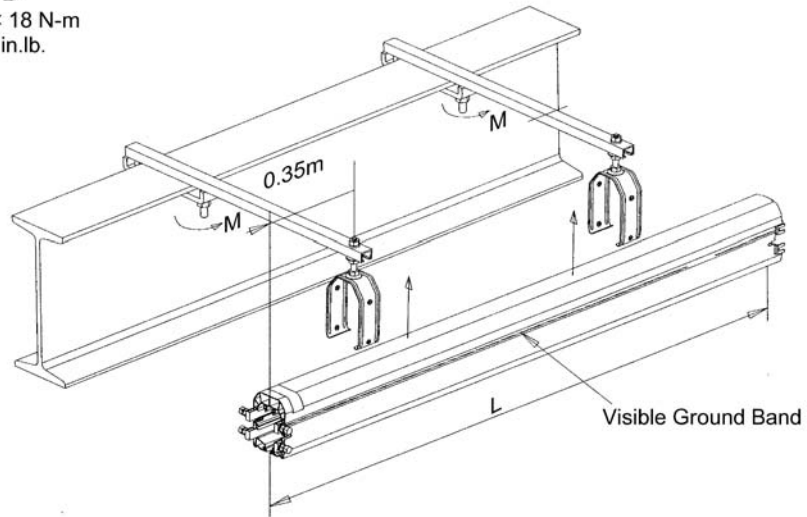

Figure 3: Bracket

Use the following to determine the number of hangers:

	20A-130A		200A		
Length	< 1.5m	1.5 – 4m	< 1.3m	1.3 – 2.6m	2.6 – 4m
Length	< 5'	5' – 13.12'	< 4.3'	4.3 – 8.5'	8.5 – 13.12'
# of Hangers	1	2	1	2	3

2. Sliding Hanger

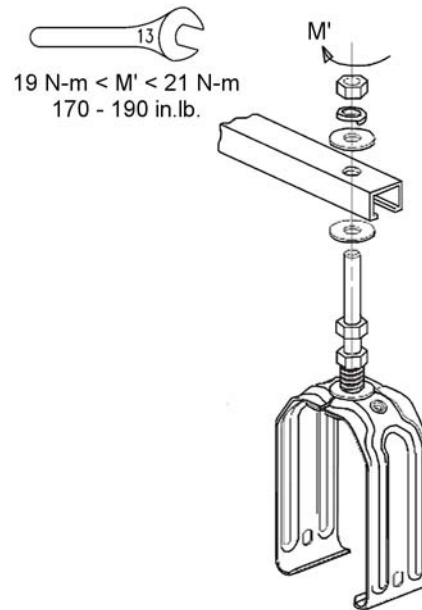
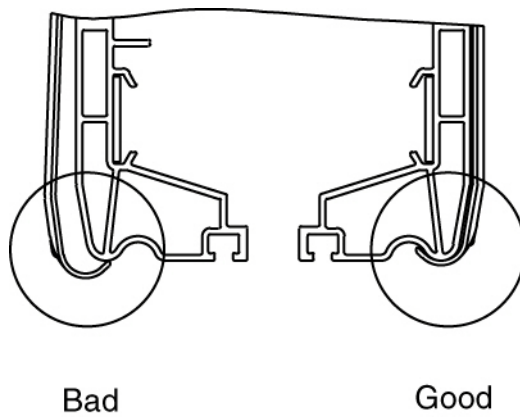

Figure 4: Sliding Hanger

NOTE: One sliding hanger must be added 350 mm (13.75") from the end of line.

3. Line Element



Be sure hangers are snapped completely under the line element.

Figure 5: Hanger Fit

4. Expansion Joint

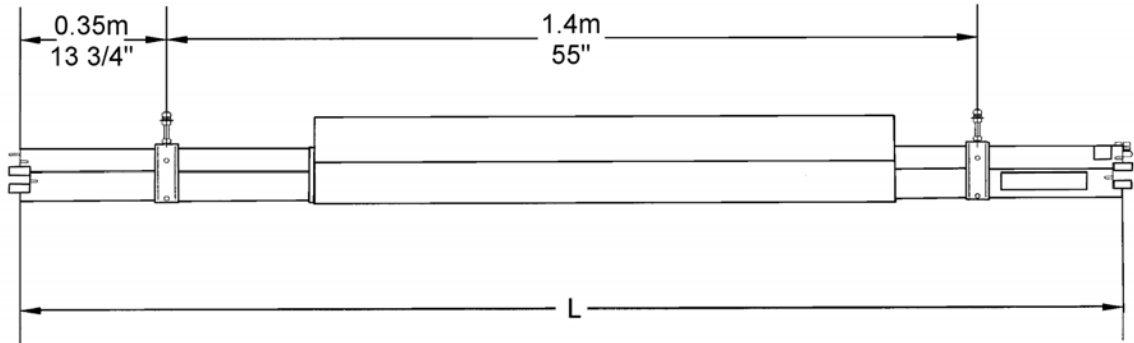
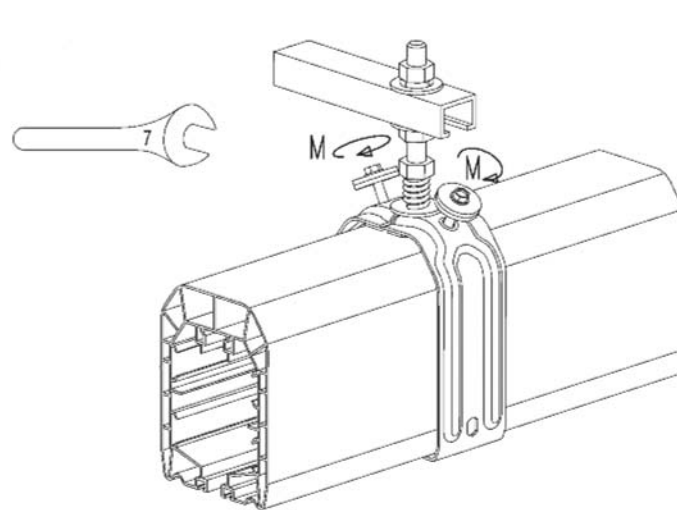

Figure 6: Expansion Joint

Adjust the expansion element to dimension "L" at time of assembly based on the ambient temperature during normal operating conditions. Refer to the chart below.

Temperature		Length	
°C	°F	mm	in
-20	-4	2005	78.93
-10	14	2000	78.73
0	82	1995	78.54
10	50	1990	78.34
20	68	1985	78.15
30	86	1980	77.95
40	104	1975	77.76
50	122	1970	77.56
60	140	1965	77.36

5. Fixed Hanger



Screw self-tapping screws into line element housing at fixed hanger locations.

$2 \text{ N-m} < M < 3 \text{ N-m}$
 $18 - 27 \text{ in.lb.}$

Figure 7: Fixed Hanger

6. Connection of Conductors

20A → 130A :

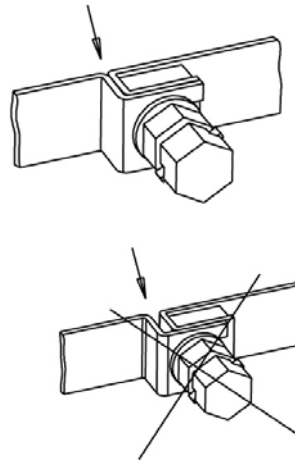

Figure 8: Eliminate conductor gaps

Make sure line element conductors are together while tightening the torque-limiting bolt.

Be sure there is no gap present at the conductor joint prior to snapping of the torque-limiting bolt.

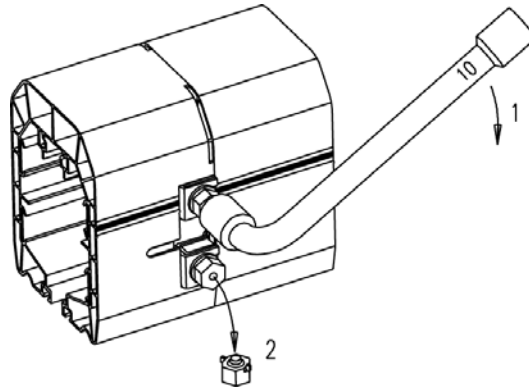

Figure 9: Bolt Heads

With even pressure, tighten upper bolt head until it snaps off.

*Be sure socket wrench does not overlap both bolt heads while tightening. Over-torquing of conductor bar could occur.

NOTE: If all upper bolt heads are not snapped off, the joint cover will not fit over the line element.

NOTE: 200 Amp systems do not have self-torquing bolts at conductor joints. 200 amp collector joints include 3mm socket screws.

200A :

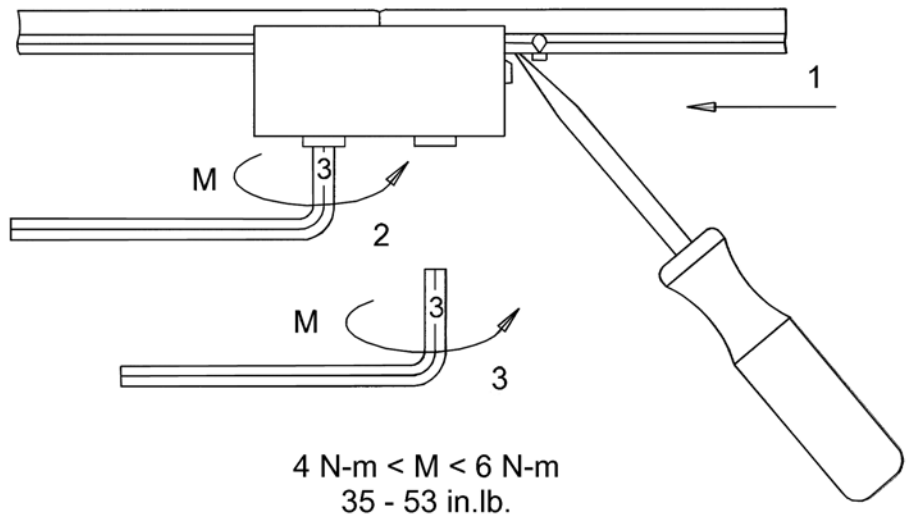
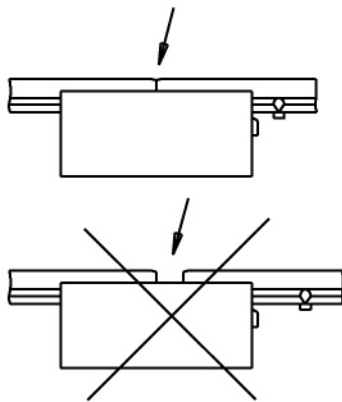

Figure 10: 200 Amp connections

A screw driver may be used to hold conductors together while tightening joint connector.

7. Joint Cover

1. Open joint cover completely. Place joint cover internal centering tabs into the gap between the line elements.
2. Rotate lower flanges of joint cover firmly under line element until each side snaps under the line element cover.
3. Rotate the (4) four joint cover locking tabs down until they snap into position.

NOTE: Cover will not fit over joint if conductor joint cover hardware is not properly assembled.

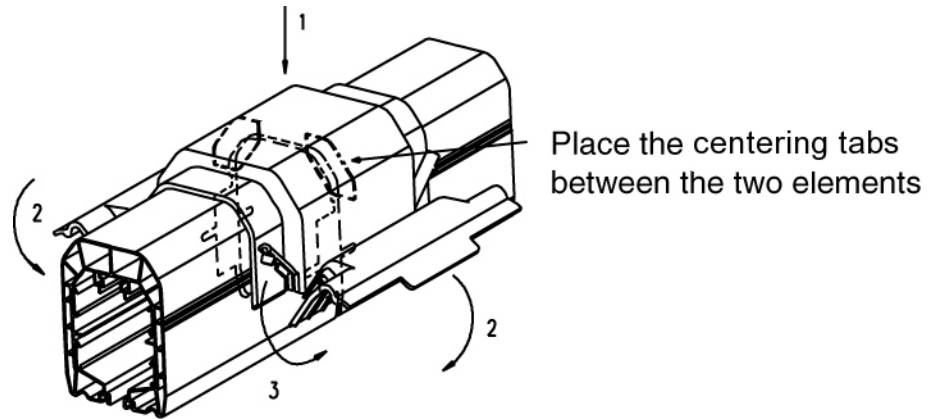

Figure 11: Joint Cover

8. Trolley

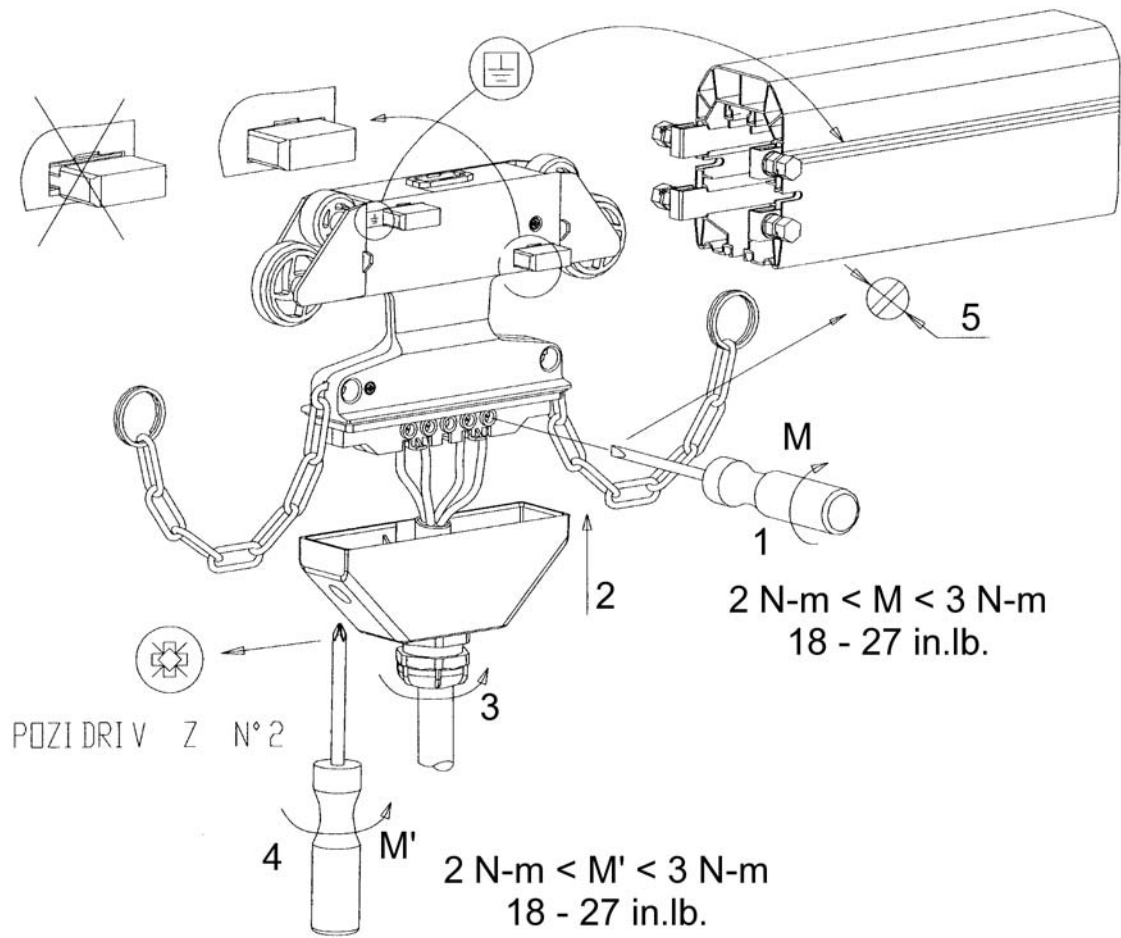

Figure 12: Trolley

1. See Figure 13 for cable trim guidelines.
2. Feed cable through cord grip on trolley cover.
3. Wire cable to trolley, check for secure terminal connection.
4. Slide trolley cover and assemble to trolley.
5. Tighten cord grip.

Slide the trolley into end of line element and be sure ground brush on the trolley is in line with the ground conductor in the line element. The ground conductor in the line element is directly under the green and yellow line on the line element cover.

Lightly hold in brushes on the trolley as it is inserted into the line element.

NOTE: *Trolleys can only be inserted into the line element in one direction. Trolleys have flanges to prevent improper assembly. If the trolley does not slide into the line element, check direction of trolley as it relates to the line element.*

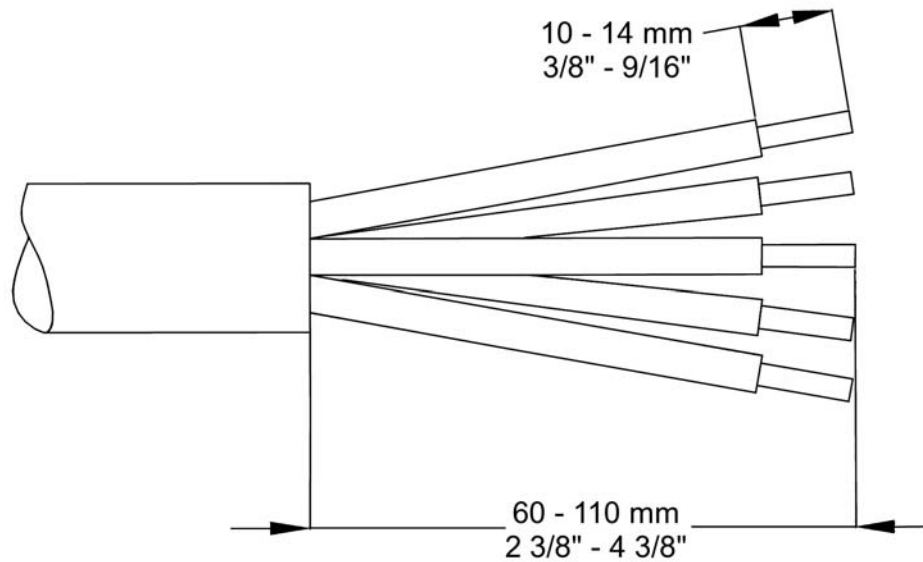

Figure 13: Trolley cable trim guidelines

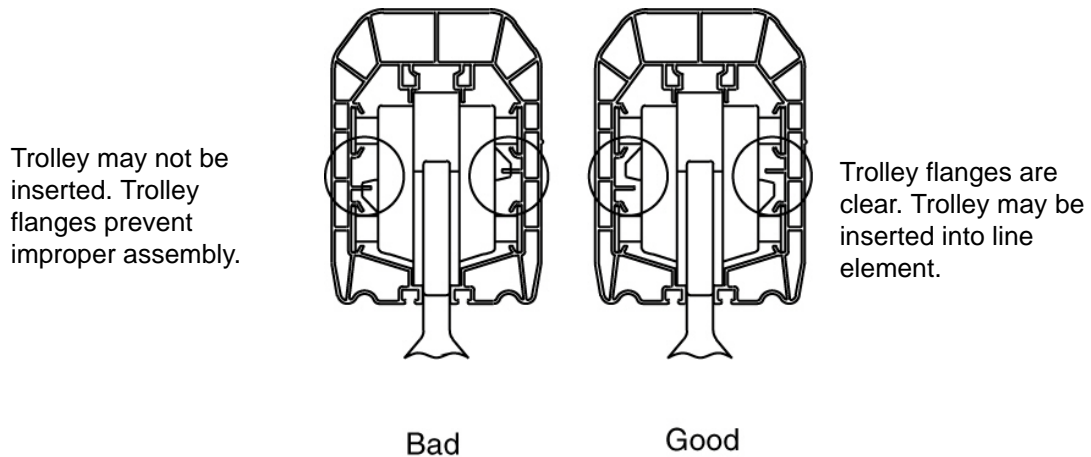

Figure 14: Trolley Flanges

 **WARNING**

Do NOT remove trolley flanges!!

 **CAUTION**

Connecting: flexible cable $\leq 4 \text{ mm}^2$ recommended, 6 mm^2 maximum. Collectors must be installed at one end of the line.

9. In-Line Feed Box

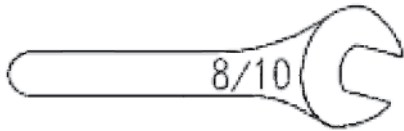

Use for attaching cable when using in-line feed boxes

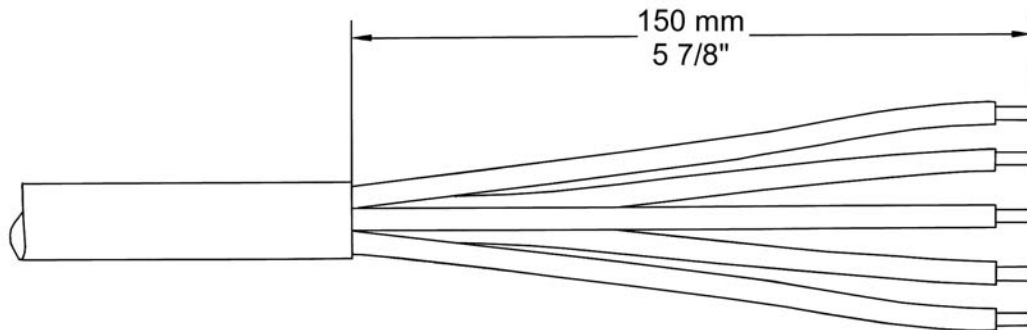

Figure 15: Power Feed cable Trim guide

NOTE: Attach appropriate flat wire terminal connector to power feed cable conductor ends. Feed cable through cord grip prior to attaching flat wire terminals.

To Open Covers:

1. Un-snap the (4) four locking tabs with a small flat screwdriver.
2. Rotate locking tabs clear from the lower half of the cover.
3. Rotate the lower half of the cover open.

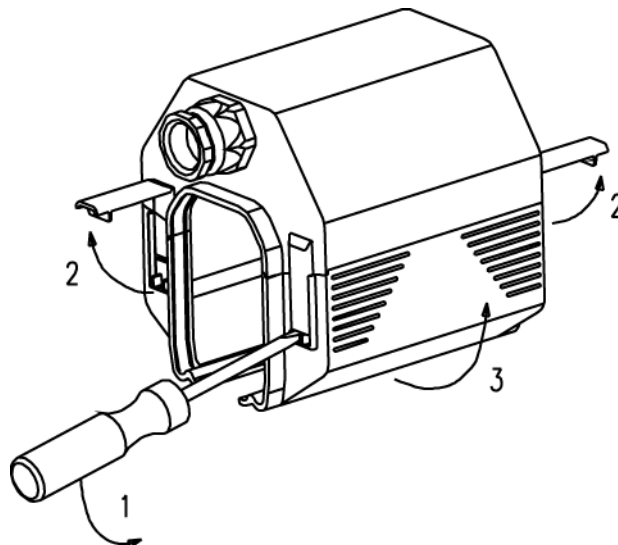
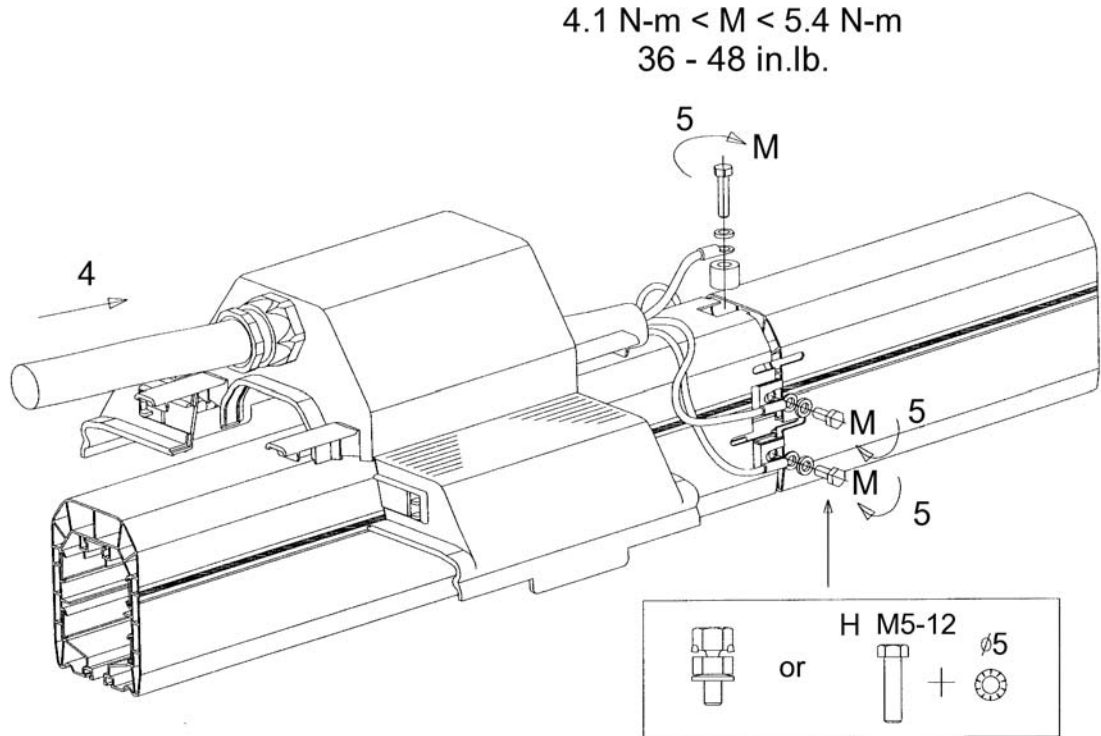

Figure 16: Feed Box Cover

Power Feed Connection

Feed the power feed cable through the cord grip in the cover, and attach the flat terminal connectors. Attach the power feed cable terminals under the joint connection bolts. Tighten the torque limiting bolts until the upper head snaps off.



Slide the power feed cover over the center of the joint. Lower the cover onto the line element. Place the cover centering tabs into the line element cover slots. Rotate and snap the lower half of the power feed cover under the line element cover. Rotate and snap the (4) four locking tabs on the side of the power feed cover into position.

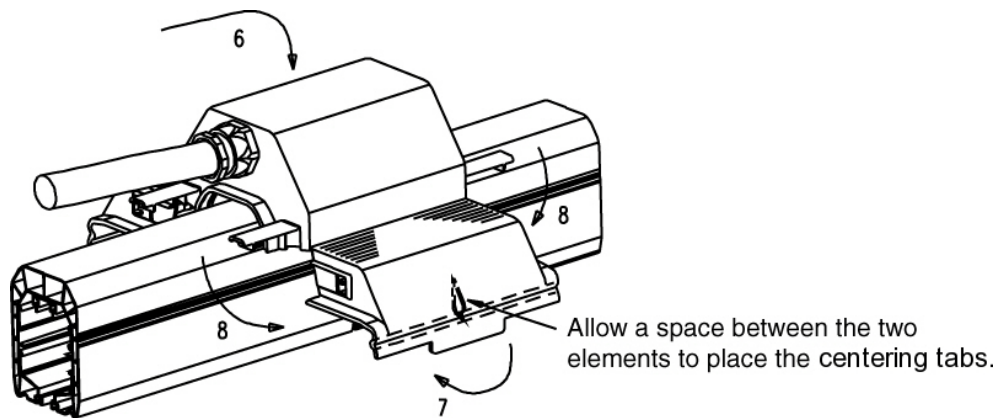

In-line Power Feed with Junction Box

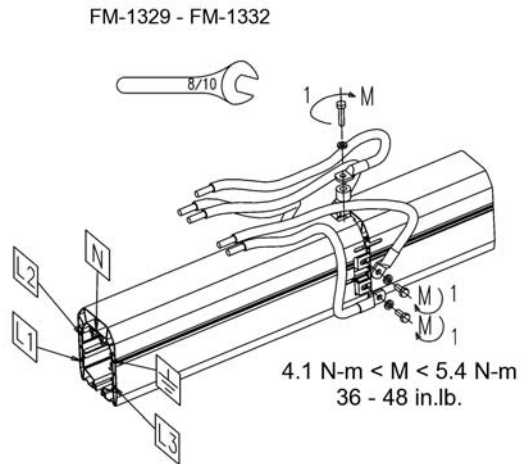

Figure 19: Installing power feed cables

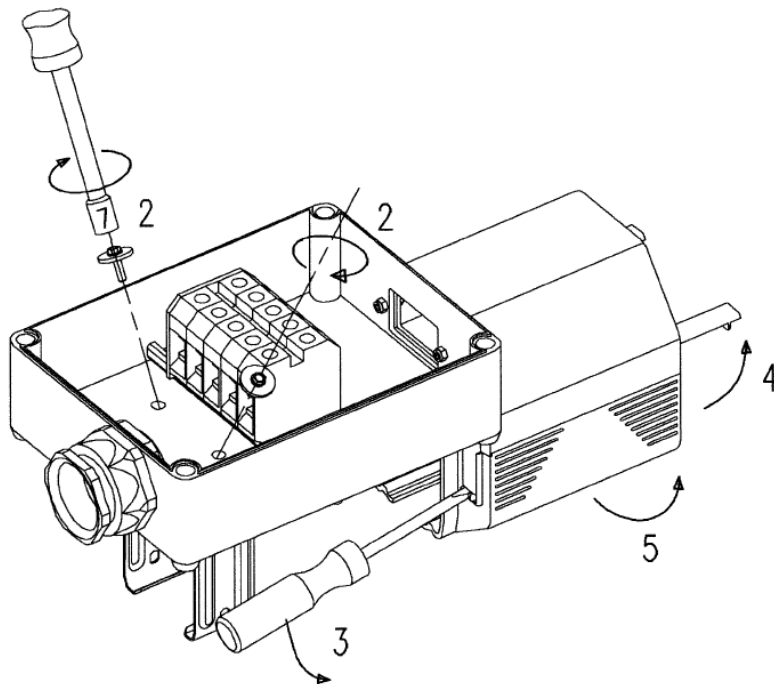

Figure 20: Opening Power Feed Cover

Open Power Feed Cover

1. With a small flat screwdriver pry open and rotate the (4) four locking tabs clear of the lower half of the cover.
2. Rotate open the lower half of the power feed cover.
3. Assemble the sliding hanger to the junction box. **DO NOT TIGHTEN AT THIS TIME.**

Feed the power feed cables into the junction box from under the power feed cover. Center the cover over the joint and rotate the assembly and hanger over the line element cover.

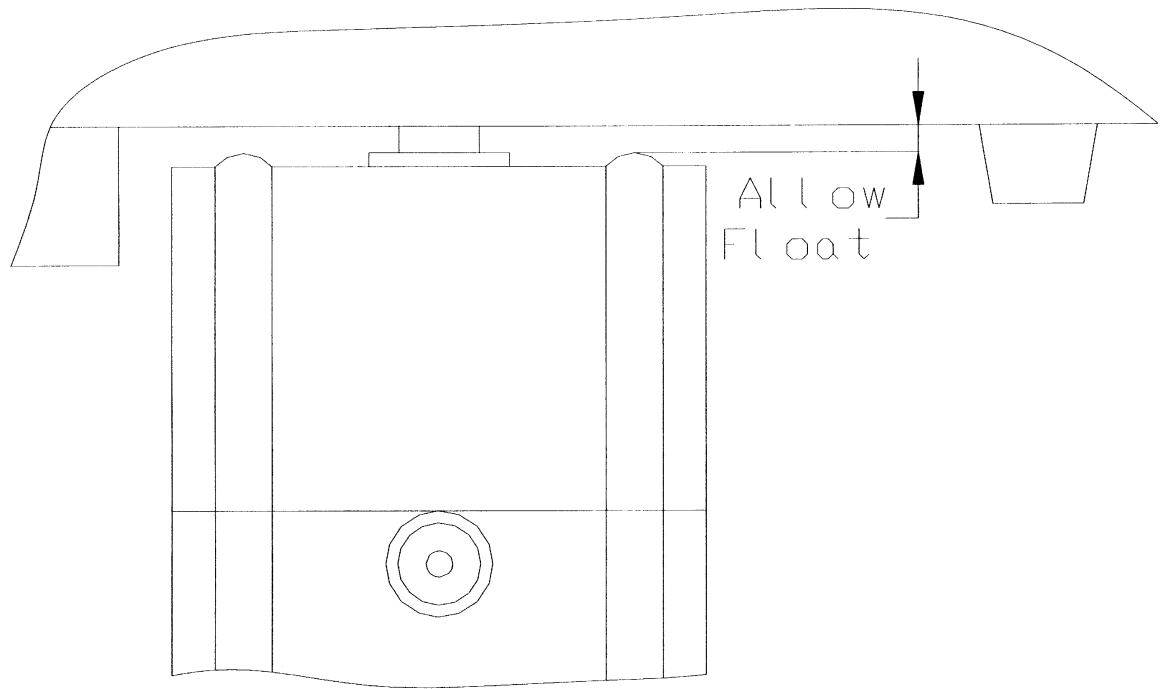

Figure 21: Placing Power Feed Cover

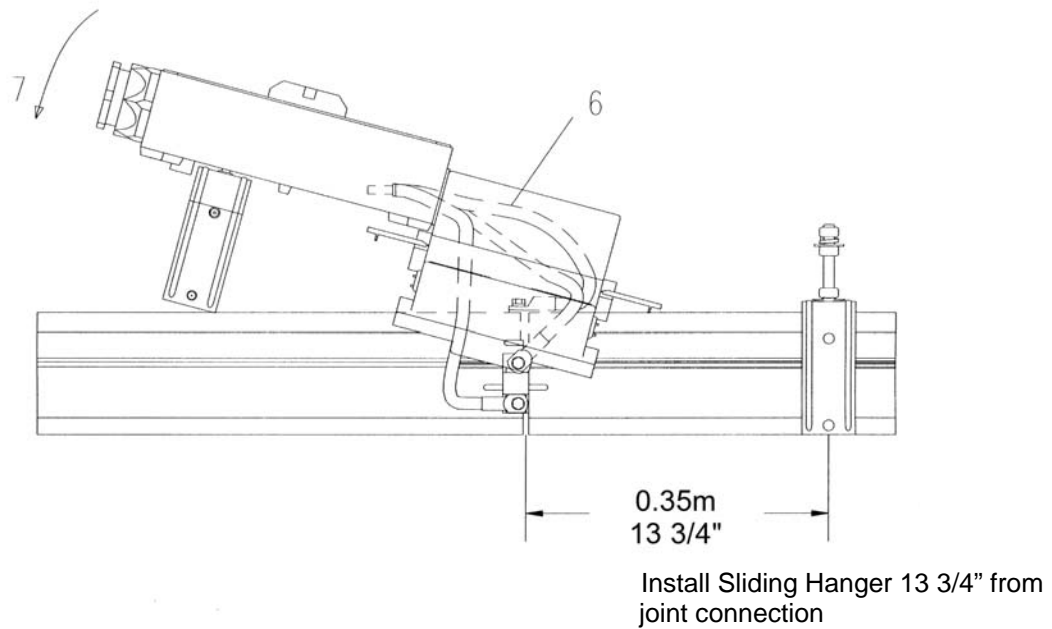
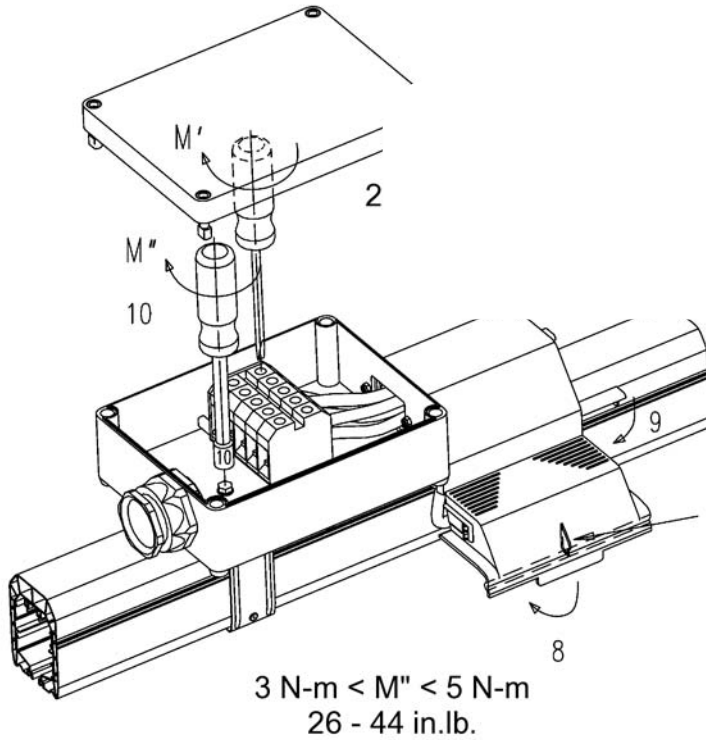

Figure 22: In Line Power Feed with Junction Box assembly

Rotate and snap the lower half of the power feed cover under the joint of the line element. Rotate locking tabs down and snap into position. Install the wires to the terminals. Tighten the hanger with the bolt in the junction box.

Insert the power cable through the cord grip. Install the power feed cable to the junction box terminals. Tighten the cord grip, and install the junction box cover.



Allow a space between the two elements to place the centering tab.

Figure 23: Placing the Power Feed Cover

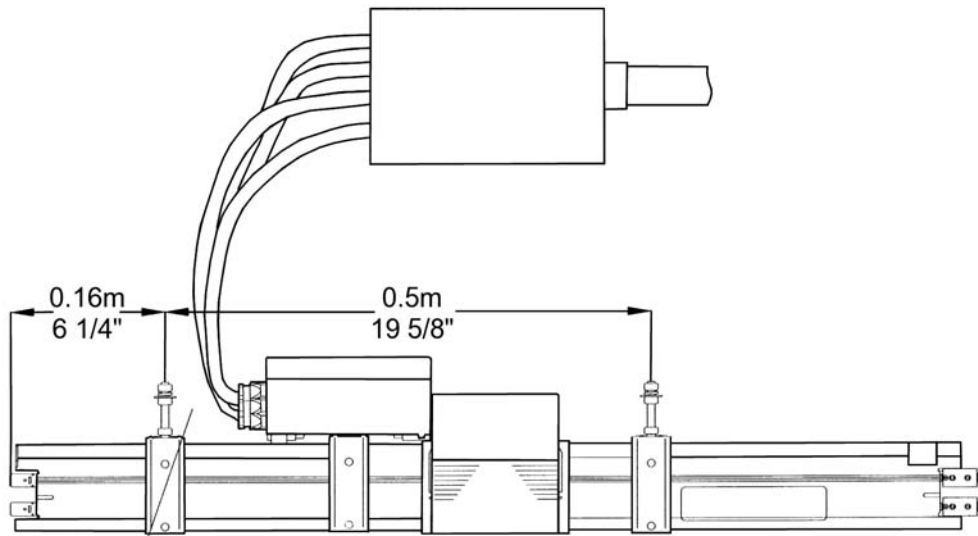

The layout of the cables and the box must not impede the expansion. Keep a minimum play of 60 mm (2 3/8").

Figure 24: In Line Power Feed with Junction Box Placement

10. End-line feed box

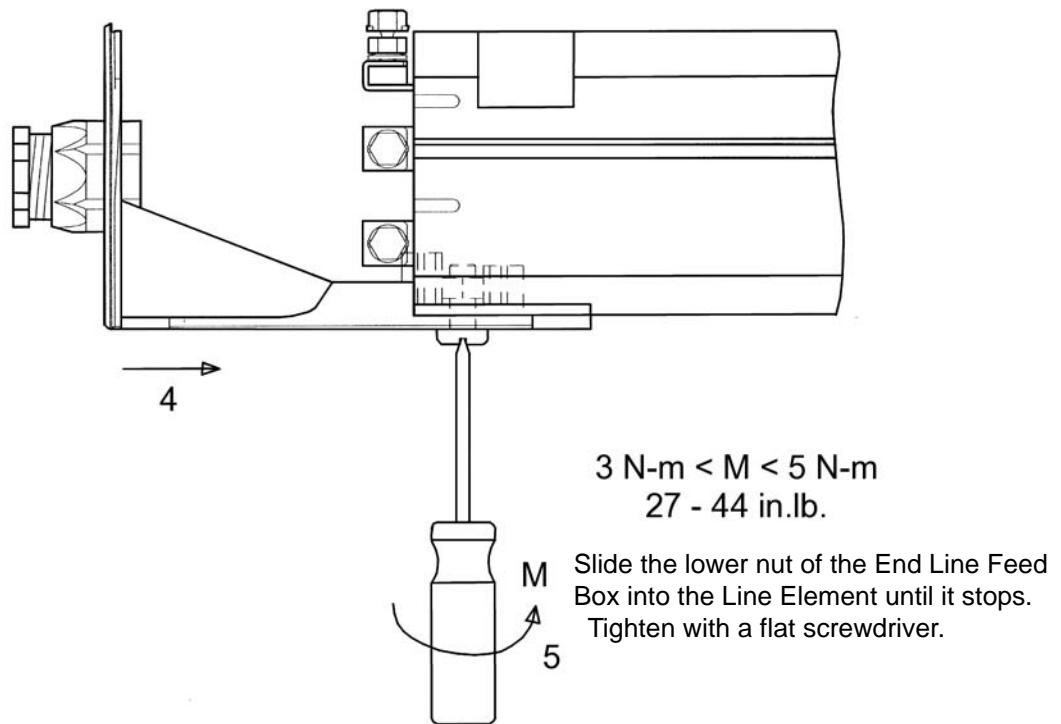

Figure 25: End Line Feed Box

Insert the power feed cable through the cord grip, and attach the flat terminal connectors. Assemble the cable to the conductor connection bolts. Tighten the cord grip.

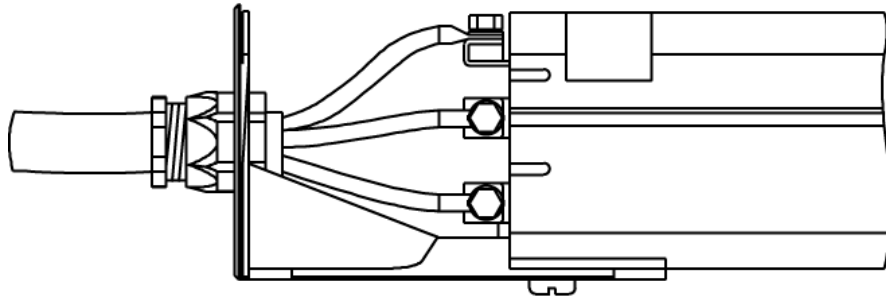

Figure 26: End Line Feed Cable Connections

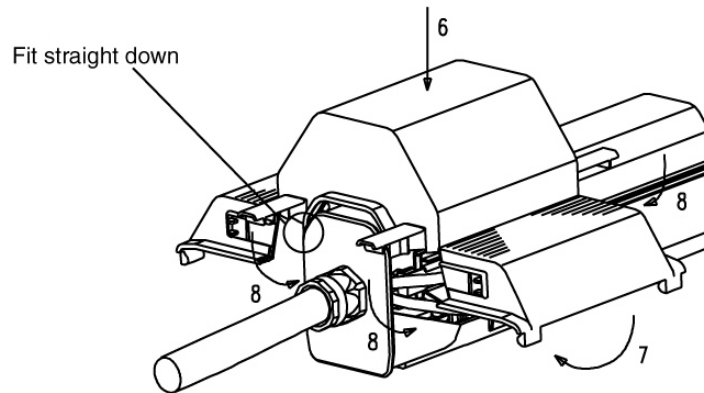

Figure 27: End Line Feed

Lower the power feed cover straight down over the end of the line element and feed cover base. Snap the lower cover halves to the base and under the line element. Rotate the (4) four locking tabs and snap into position.

11. End Cap

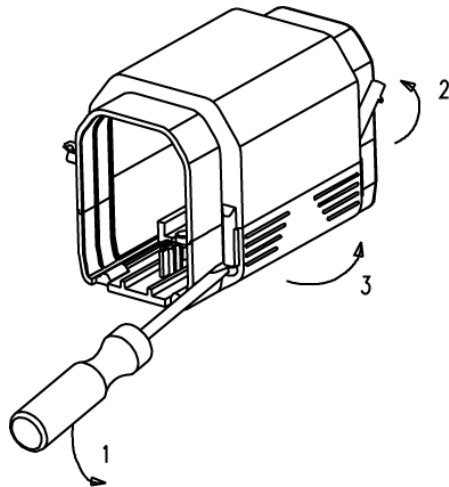

Figure 28: End Cap Cover

Open the end cap cover. Pry the (4) four locking tabs open with small flat screwdrivers. Rotate clear of lower half of cover. Rotate lower halves of the end cover open.

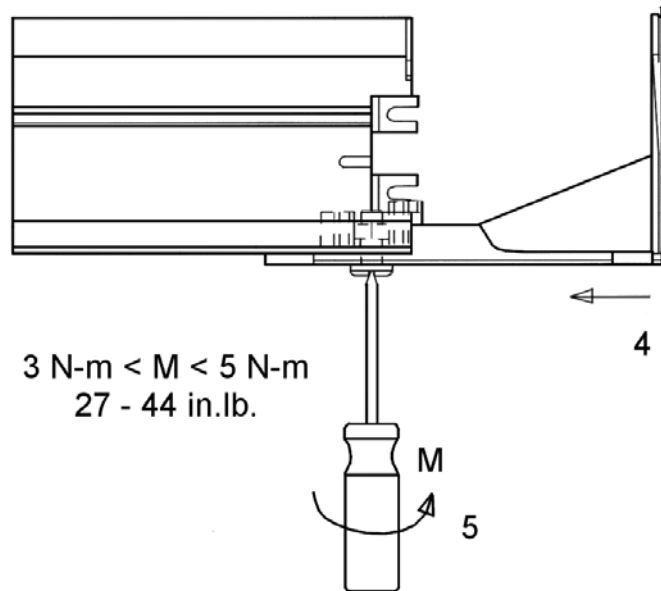

Figure 29: End Cap Placement

Slide the lower nut of the end cap into line element slot until it stops. Tighten with flat screwdriver.

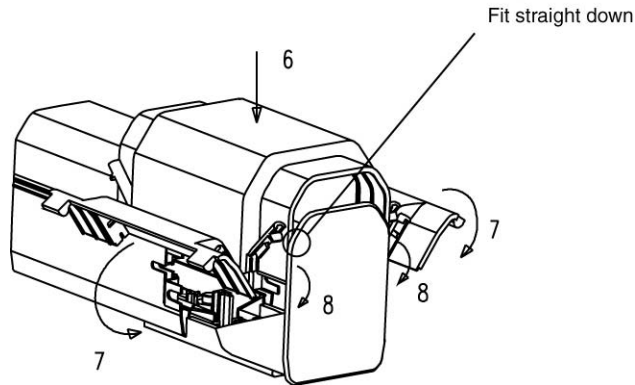
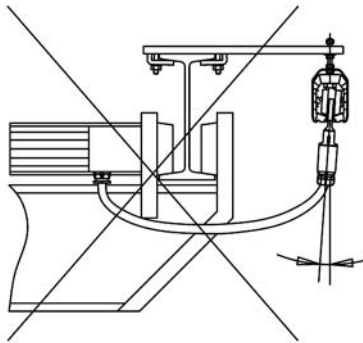

Figure 30: End Cap Final Assembly

Lower the end cap cover straight down over the end of line element and the end cap base. Rotate the lower half of the end cap cover and snap into position. Rotate down and snap the (4) four locking tabs into position.

12. Connecting The Trolley



Do not allow the trolley cable to pull the trolley to the side. Premature trolley wheel and brush wear can occur.

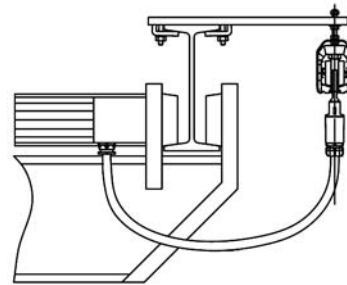

The cable is to hang straight down from the trolley.

Figure 31: Trolley connections

13. Tow Brackets

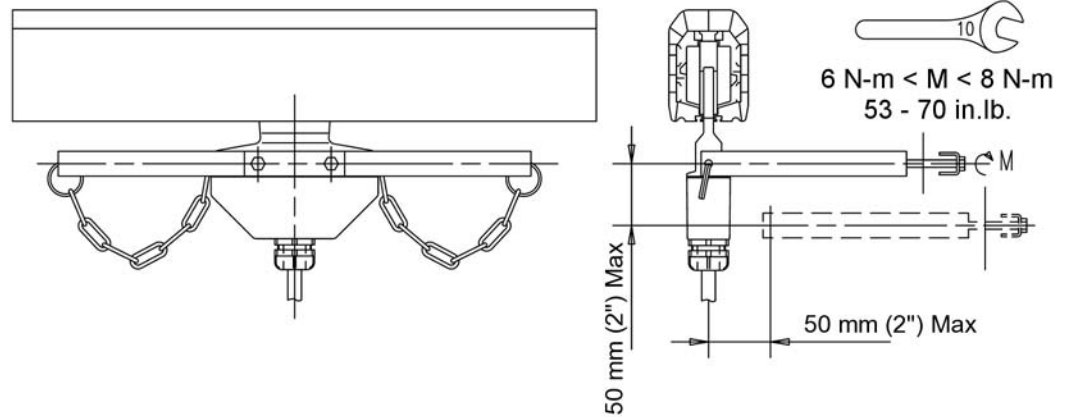

50 mm maximum deviation of tow bracket from trolley at any point over the length of the system.

Figure 32: Tow Brackets

Cutting Line Elements On Site

20-130 A Instructions

1. Cut the line element at least 4" longer than necessary (Figure 33).
2. Pull conductors inside far enough so that the final cut does not recut the conductors (Figure 33).
3. Make the final cut on the PVC extrusion only. Deburr the PVC extrusion to ensure the conductor bar moves freely.
4. With a small rotary tool make a minimum 11/16" long notch with a 1/8"-5/16" width on each side of the bar (Figure 34). This notch is important to prevent tracking (conduction across the surface of the plastic) of electricity between the phases.
 - a. The notch should be located between the safety tab and the pocket where the conductor bar is located. Sides are not symmetrical (Figure 34).
5. Push the conductors back in as far as they will go, measure 1/4" from the cut PVC edge, and bend each conductor away from the center of the part (Figure 35). The conductors should have 3/16"-5/16" play inside the extrusion when this is done, and not should be able to pull inside the extrusion.
6. Trim excess conductor, leaving a 3/8" tab (Figure 35). Make sure that the tabs fit properly under the end cover.



WARNING

The cut end must be used at the end of the line, and it must be capped with an end cap. Failure to ensure that the conductors cannot be moved more than 5/16" could result in exposed conductors, which could result in death or serious injury.

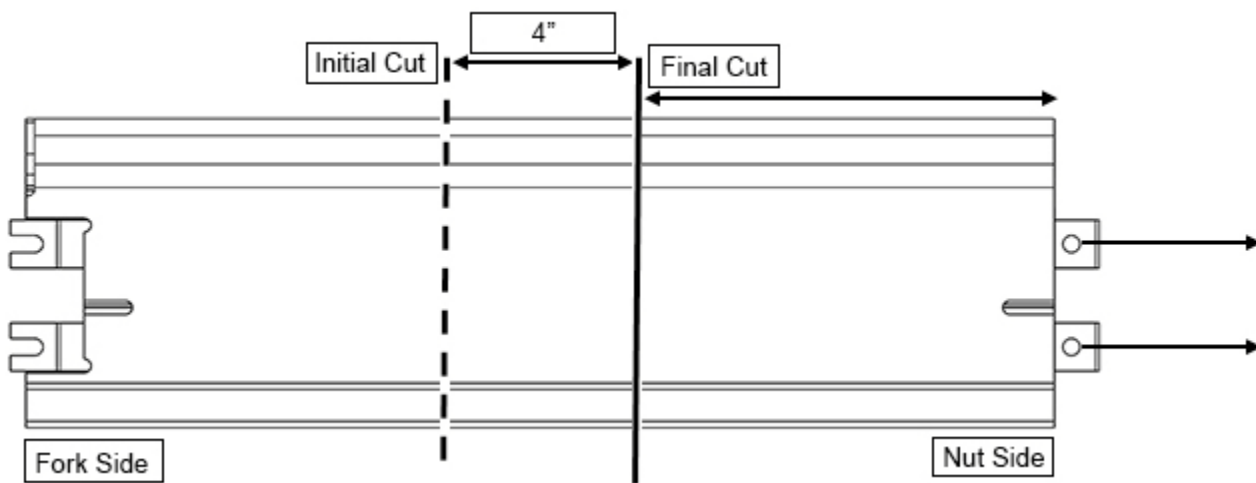

Figure 33: Side View (20-130 A)

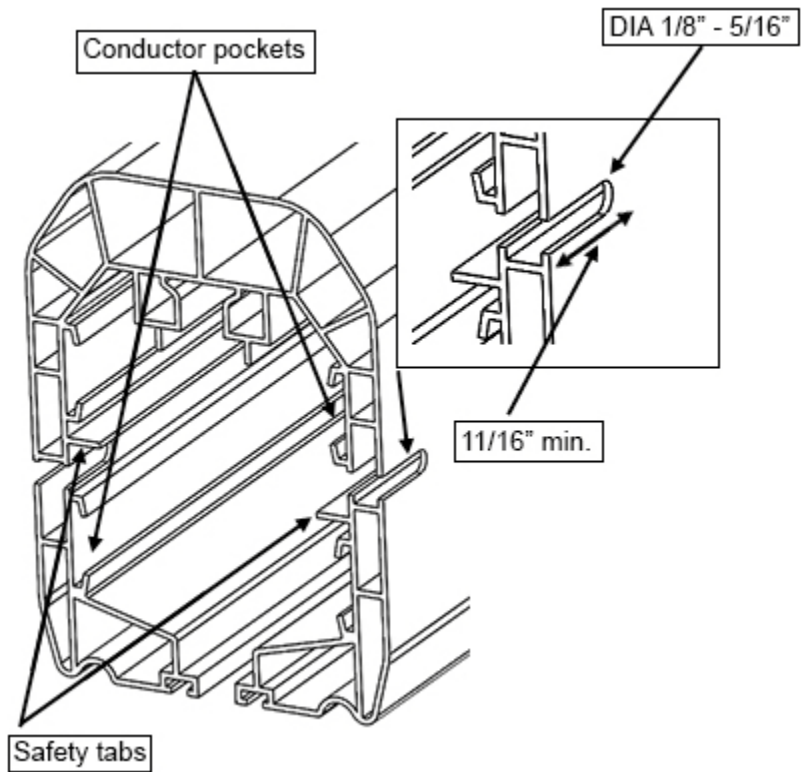

Figure 34: Notch Placement (20-130 A)

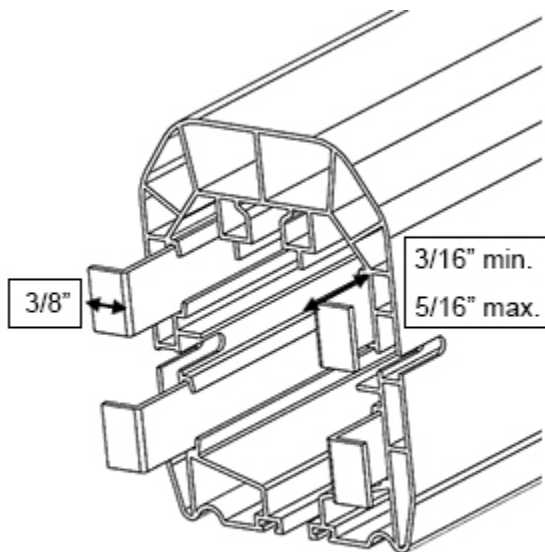



Figure 35: Conductor Placement (20-130 A)

200 A Instructions

1. Cut the line element at least 4" longer than necessary (Figure 36).
2. Pull conductors inside far enough so that the final cut does not recut the conductors (Figure 36).
3. Make the final cut on the PVC extrusion only. Deburr the PVC extrusion to ensure the conductor bar moves freely.
4. With a small rotary tool, make a minimum 11/16" long notch with a 1/8"-5/16" width bit on each side of the bar (Figure 37). This notch is important to prevent tracking (conduction across the surface of the plastic) of electricity between the phases.
 - a. The notch should be located between the safety tab and the pocket where the conductor bar is located. Sides are not symmetrical (Figure 37).
5. Push the conductor bars back in as far as they will go, measure 1/4" from the cut PVC edge, and dimple the bar with a punch or chisel so that the flat part of the bar is raised at least 1/16" (Figure 38). The conductors should have 3/16"-5/16" play inside the extrusion when this is done, and should not be able to pull inside the extrusion.
6. Trim excess bar leaving a 1" tab (Figure 38). Make sure that the excess fits properly under the end cover.

**WARNING**

The cut end must be used at the end of the line, and it must be capped with an end cap. Failure to ensure that the conductors cannot be moved more than 5/16" could result in exposed conductors, which could result in death or serious injury.

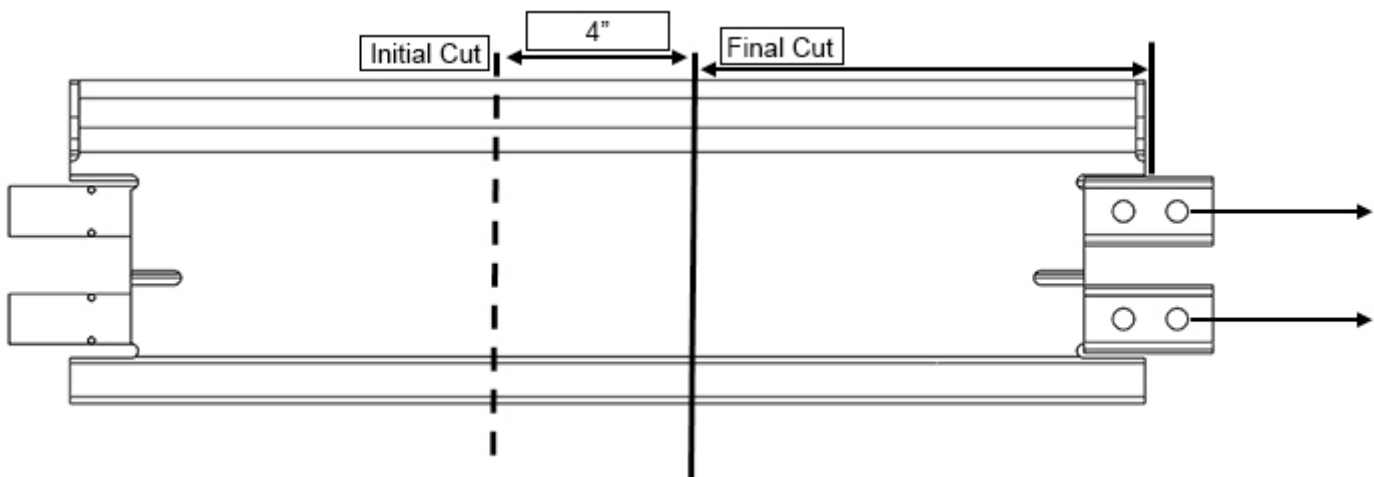

Figure 36: Side View (200 A)

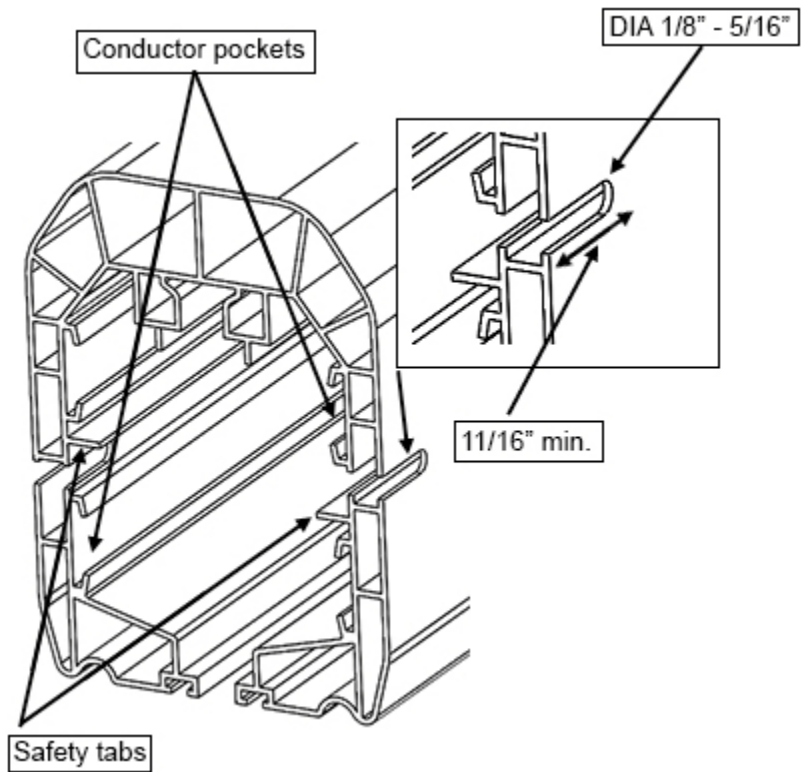

Figure 37: Notch Placement (200 A)

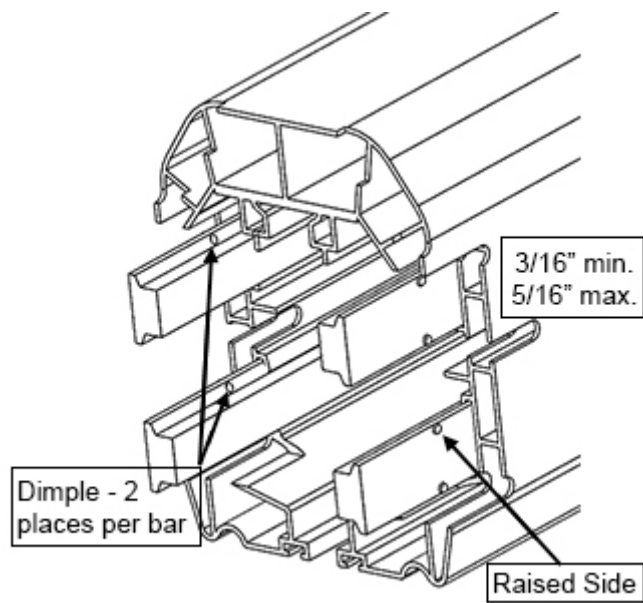

Figure 38: Conductor Placement (200 A)

Curved Applications

Before Assembly

**CAUTION**

Do not remove the straps from the curves before assembly on site. Do not try to take off the grey pieces, or the curve may be destroyed.

All curves have an identification label:

ME4220 **08/2003**

R=2.25m **a=60**

$L_{Dth} = 2.356 \text{ m}$

Expansion Placement

If an expansion joint is planned between two curves, it is imperative that it be placed at equal distance between the curves.

Fixed Hanger Placement

**CAUTION**

Always place a fixed hanger on all curves. There is a risk of unhooking due to expansion.

Fixed Hanger Requirements	
If Length of arc < 0.8m (2.62')	1 fixed hanger
If Length of arc is 0.8m - 3m (2.62' - 9.84')	2 fixed hangers
If Length of arc > 3m (9.84')	3 fixed hangers

Connecting Curved Elements

The last section, at the end of each curve, makes a 3 degree angle with the next element.

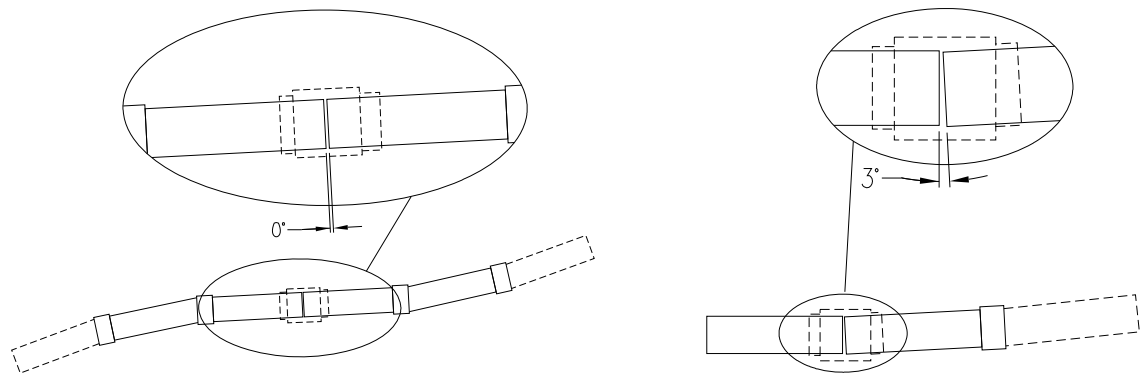

Covering flange FM-1000 or Feed Box FM-1300 or FM-1330

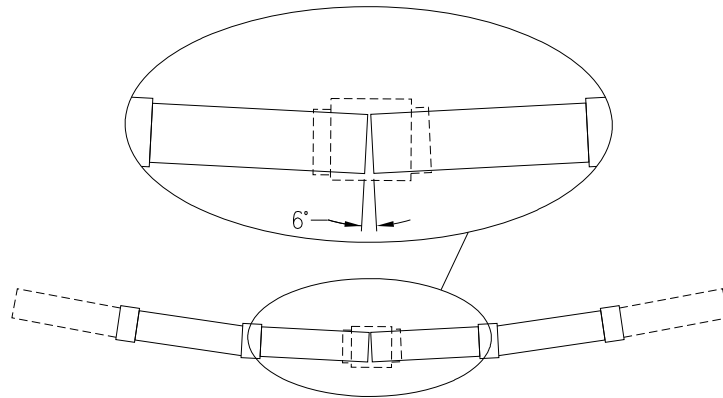

Covering flange FM-1000-CO or Feed Box FM-1300-CO or FM-1330-CO

Figure 39: Curved Line Element placement

Assembly Procedure

1. Put the fixed hangers on the mounting brackets (refer to Section 5 on page 10).
2. Put the curve in the fixed hangers without fixing anchoring screws. (Warning: at rest the radius of the curve is greater than the nominal radius due to flexibility in the element.)
3. Assemble connection on one side, conductors abutting each other.
4. Place the next element in the hangers, then close a little bit of the curve to place the remaining curve connections.
5. Install the joint covers (refer to Section 7 on page 12). Use FM-2000 for straight sections and FM-2000-CO for curves.
6. Tighten the fixed hanger screws.
7. Special Articulated trolleys (single/double/triple) are required on all installations with a curve.