

Flex VUE™ Transmitter

Remote Equipment Control



MAGNETEK
RADIO CONTROLS

July 2013
Part Number: 198-80200-0001 R4
© 2013 Magnetek Material Handling

Your New Radio Remote

Thank you for your purchase of Magnetek's Flex VUE™ Radio Remote Equipment Control. Magnetek has set a whole new standard in radio-remote performance, dependability, and value with this unique new line of handheld transmitters.

If your product ever needs modification or service, please contact one of our representatives at the following locations:

U.S. Service Information

For questions regarding service or technical information contact:
+1.866.MAG.SERV
+1.866.624.7378

International Service

+1.262.783.3500

World Headquarters:

Magnetek, Inc.
N49 W13650 Campbell Drive
Menomonee Falls, WI 53051

Telephone: +1.800.288.8178
Website: www.magnetekmh.com
e-mail: info@magnetekmh.com

Fax Numbers:

Main: +1.800.298.3503
Sales: +1.262.783.3510
Service: +1.262.783.3508

Canada Service Information:

4090B Sladeview Crescent
Mississauga, Ontario
L5L 5Y5 Canada
Phone: +1.800.792.7253
Fax: +1.905.828.5707
+1.416.424.7617 (24/7 Service pager)

EU Market Contact:

Brian Preston
Magnetek (UK) Ltd.
20 Drakes Mews, Crownhill
Milton Keynes, MK8 0ER UK
Phone: +44.1908.261427
Fax: +44.1908.261674

©2013 MAGNETEK

All rights reserved. This notice applies to all copyrighted materials included with this product, including, but not limited to, this manual and software embodied within the product. This manual is intended for the sole use of the person(s) to whom it was provided, and any unauthorized distribution of the manual or dispersal of its contents is strictly forbidden. This manual may not be reproduced in whole or in part by any means whatsoever without the expressed written permission of MAGNETEK.

TABLE OF CONTENTS

1.0	INTRODUCTION.....	5
1.1	PRODUCT MANUAL SAFETY INFORMATION	5
2.0	WARNINGS AND CAUTIONS	6
2.1	CRITICAL INSTALLATION CONSIDERATIONS	7
2.2	GENERAL.....	7
2.3	PERSONS AUTHORIZED TO OPERATE RADIO CONTROLLED MACHINERIES.....	7
2.4	SAFETY INFORMATION AND RECOMMENDED TRAINING FOR RADIO CONTROLLED EQUIPMENT OPERATORS	8
2.5	TRANSMITTER UNIT.....	9
2.6	PRE-OPERATION TEST.....	9
2.7	HANDLING BATTERIES	10
2.8	OPTIONAL RECHARGABLE BATTERY CHARGING	10
2.9	BATTERY DISPOSAL	10
3.0	FLEX VUE™ TRANSMITTER STANDARD CONFIGURATON AND OPERATION	11
3.1	INSTALLING BATTERY COMPARTMENT.....	14
3.1.1	Alkaline Battery Replacement	14
3.2	TURNING THE TRANSMITTER ON AND OFF	15
3.2.1	Turning On the Transmitter	15
3.2.2	Proportional Button Calibration	16
3.2.3	Pulling In the Machine Stop Relay	16
3.2.4	Turning Off the Transmitter	16
3.2.5	Removing Power Switch Key	17
3.3	MACHINE STOP SWITCH (FOR EMERGENCY STOPPING ONLY)	17
3.4	USING PUSHBUTTONS FOR OPERATION	17
3.4.1	Proportional Push Button Control.....	17
3.4.2	2-Step Push Button Control.....	17
3.5	NORMAL OPERATING MODE – DISPLAY FEATURES/FUNCTIONS	17
3.5.1	Watch Dog Indicator (Sweeping Dot).....	18
3.5.2	Max Button Output Indicator (Percentage).....	18
3.5.3	Battery Life Indicator	18
3.5.4	Command Confirmation	18
3.5.5	Signal Strength Indicator	19
3.5.6	Two-Way Feedback System	19
3.6	NORMAL OPERATING MODE – STATUS LED indications.....	19
4.0	TRANSMITTER SETUP.....	20
4.1	USING THE TRANSMITTER IN SETUP MODE	20
4.2	ENTERING SETUP MODE	20
4.2.1	Entering Setup During Start Up.....	20
4.2.2	Entering Setup During Normal Operation	20
4.3	ADJUSING SETTINGS IN SETUP MODE	21
4.3.1	Access Code	21
4.3.2	Channel Select	21
4.3.3	RF Power.....	21
4.3.4	Transmitter Inactivity Timeout	22
4.3.5	Backlight Power %	22
4.3.6	Backlight Timeout	22
4.3.7	Set Clock	23
4.3.8	Password Enable	23
4.3.9	Change Password	23
4.3.10	IR Configuration Receiver	23
4.3.11	Exit With Save	24
4.3.12	Exit Without Save	24
5.0	OPTIONAL PROGRAMMING WITH RCP	25

5.1	ACCESS CODES	25
5.2	CONNECTING THE FLEX VUE™ TO A COMPUTER	25
5.3	PROGRAMMING WITH RCP	26
5.3.1	FLEX VUE™ Configuration Page.....	29
5.3.2	Saving, Downloading, and Reading the Programs and Other RCP Software Functions.....	32
6.0	CLEANING THE TRANSMITTER.....	34
7.0	TRANSMITTER RF CHANNEL CONFIGURATION SETTINGS	35
7.1	FCC STATEMENTS	35
7.2	CHANNEL AND FREQUENCY DESIGNATIONS BY COUNT	36
7.3	OPTIONAL FREQUENCIES AND CHANNELS	37
7.3.1	2.4 GHz: FHSS.....	37
7.3.2	433 MHz Telemotive Legacy Channel Set: TMS	37
7.3.3	419 MHz Extended Channel Set: TMS	38
8.0	TROUBLESHOOTING	39
8.1	GENERAL TROUBLESHOOTING	39
8.2	ASSEMBLY AND REPLACEMENT PARTS	40
9.0	EU DECLARATION OF CONFORMITY	41

1.0 INTRODUCTION

Thank you for your purchase of Magnetek's Flex VUE™ Radio Remote Equipment Control.

These instructions are to be used as a reference for personnel operating the Flex VUE™ Radio Remote Equipment Control and the equipment that this Flex VUE™ Radio Remote Equipment Control is attached to.

The user of these instructions should have basic knowledge in the handling of electronic equipment.

1.1 PRODUCT MANUAL SAFETY INFORMATION

Magnetek, Inc. (Magnetek) offers a broad range of radio remote control products, control products and adjustable frequency drives, and industrial braking systems for overhead material handling applications. This manual has been prepared by Magnetek to provide information and recommendations for the installation, use, operation and service of Magnetek's material handling products and systems (Magnetek Products). Anyone who uses, operates, maintains, services, installs or owns Magnetek Products should know, understand and follow the instructions and safety recommendations in this manual for Magnetek Products.

The recommendations in this manual do not take precedence over any of the following requirements relating to cranes, hoists and lifting devices:

- Instructions, manuals, and safety warnings of the manufacturers of the equipment where the radio system is used,
- Plant safety rules and procedures of the employers and the owners of facilities where the Magnetek Products are being used,
- Regulations issued by the Occupational Health and Safety Administration (OSHA),
- Applicable local, state or federal codes, ordinances, standards and requirements, or
- Safety standards and practices for the overhead material handling industry.

This manual does not include or address the specific instructions and safety warnings of these manufacturers or any of the other requirements listed above. It is the responsibility of the owners, users and operators of the Magnetek Products to know, understand and follow all of these requirements. It is the responsibility of the owner of the Magnetek Products to make its employees aware of all of the above listed requirements and to make certain that all operators are properly trained. **No one should use Magnetek Products prior to becoming familiar with and being trained in these requirements.**

WARRANTY INFORMATION

FOR INFORMATION ON MAGNETEK'S PRODUCT WARRANTIES BY PRODUCT TYPE, PLEASE VISIT WWW.MAGNETEKMH.COM.

2.0 WARNINGS AND CAUTIONS

Throughout this document WARNING and CAUTION statements have been deliberately placed to highlight items critical to the protection of personnel and equipment.

WARNING – A warning highlights an essential operating or maintenance procedure, practice, etc. which, if not strictly observed, could result in injury or death of personnel, or long term physical hazards. Warnings are highlighted as shown below:



CAUTION – A caution highlights an essential operating or maintenance procedure, practice, etc. which if not strictly observed, could result in damage to, or destruction of equipment, or loss of functional effectiveness. Cautions are highlighted as shown below:



WARNINGS and CAUTIONS SHOULD NEVER BE DISREGARDED.

The safety rules in this section are not intended to replace any rules or regulations of any applicable local, state, or federal governing organizations. Always follow your local lockout and tagout procedure when maintaining any radio equipment. The following information is intended to be used in conjunction with other rules or regulations already in existence. It is important to read all of the safety information contained in this section before installing or operating the Radio Control System.

2.1 CRITICAL INSTALLATION CONSIDERATIONS



PRIOR TO INSTALLATION AND OPERATION OF THIS EQUIPMENT, READ AND DEVELOP AN UNDERSTANDING OF THE CONTENTS OF THIS MANUAL AND THE OPERATION MANUAL OF THE EQUIPMENT OR DEVICE TO WHICH THIS EQUIPMENT WILL BE INTERFACED. FAILURE TO FOLLOW THIS WARNING COULD RESULT IN SERIOUS INJURY OR DEATH AND DAMAGE TO EQUIPMENT.

ALL EQUIPMENT MUST HAVE A MAINLINE CONTACTOR INSTALLED AND ALL TRACKED CRANES, HOISTS, LIFTING DEVICES AND SIMILAR EQUIPMENT MUST HAVE A BRAKE INSTALLED. FAILURE TO FOLLOW THIS WARNING COULD RESULT IN SERIOUS INJURY OR DEATH AND DAMAGE TO EQUIPMENT.

AN AUDIBLE AND/OR VISUAL WARNING MEANS MUST BE PROVIDED ON ALL REMOTE CONTROLLED EQUIPMENT AS REQUIRED BY CODE, REGULATION, OR INDUSTRY STANDARD. THESE AUDIBLE AND/OR VISUAL WARNING DEVICES MUST MEET ALL GOVERNMENTAL REQUIREMENTS. FAILURE TO FOLLOW THIS WARNING COULD RESULT IN SERIOUS INJURY OR DEATH AND DAMAGE TO EQUIPMENT.

FOLLOW YOUR LOCAL LOCKOUT TAGOUT PROCEDURE BEFORE MAINTAINING ANY REMOTE CONTROLLED EQUIPMENT. ALWAYS REMOVE ALL ELECTRICAL POWER FROM THE CRANE, HOIST, LIFTING DEVICE OR SIMILAR EQUIPMENT BEFORE ATTEMPTING ANY INSTALLATION PROCEDURES. DE-ENERGIZE AND TAGOUT ALL SOURCES OF ELECTRICAL POWER BEFORE TOUCH-TESTING ANY EQUIPMENT. FAILURE TO FOLLOW THIS WARNING COULD RESULT IN SERIOUS INJURY OR DEATH AND DAMAGE TO EQUIPMENT.

THE DIRECT OUTPUTS OF THIS PRODUCT ARE NOT DESIGNED TO INTERFACE DIRECTLY TO TWO STATE SAFETY CRITICAL MAINTAINED FUNCTIONS, I.E., MAGNETS, VACUUM LIFTS, PUMPS, EMERGENCY EQUIPMENT, ETC. A MECHANICALLY LOCKING INTERMEDIATE RELAY SYSTEM WITH SEPARATE POWER CONSIDERATIONS MUST BE PROVIDED. FAILURE TO FOLLOW THIS WARNING COULD RESULT IN SERIOUS INJURY OR DEATH OR DAMAGE TO EQUIPMENT.

2.2 GENERAL

Radio controlled material handling equipment operates in several directions. Cranes, hoists, lifting devices and other material handling equipment can be large, and operate at high speeds. Quite frequently, the equipment is operated in areas where people are working in close proximity to the material handling equipment. **The operator must exercise extreme caution at all times.** Workers must constantly be alert to avoid accidents. The following recommendations have been included to indicate how careful and thoughtful actions may prevent injuries, damage to equipment, or even save a life.

2.3 PERSONS AUTHORIZED TO OPERATE RADIO CONTROLLED MACHINERIES

Only properly trained persons designated by management should be permitted to operate radio controlled equipment.

Radio controlled cranes, hoists, lifting devices and other material handling equipment should not be operated by any person who cannot read or understand signs, notices and operating instructions that pertain to the equipment.

Radio controlled equipment should not be operated by any person with insufficient eyesight or hearing or by any person who may be suffering from a disorder or illness, is taking any medication that may cause loss of equipment control, or is under the influence of alcohol or drugs.

2.4 SAFETY INFORMATION AND RECOMMENDED TRAINING FOR RADIO CONTROLLED EQUIPMENT OPERATORS

Anyone being trained to operate radio controlled equipment should possess as a minimum the following knowledge and skills before using the radio controlled equipment.

The operator should:

- have knowledge of hazards pertaining to equipment operation
- have knowledge of safety rules for radio controlled equipment
- have the ability to judge distance of moving objects
- know how to properly test prior to operation
- be trained in the safe operation of the radio transmitter as it pertains to the crane, hoist, lifting device or other material handling equipment being operated
- have knowledge of the use of equipment warning lights and alarms
- have knowledge of the proper storage space for a radio control transmitter when not in use
- be trained in transferring a radio control transmitter to another person
- be trained how and when to report unsafe or unusual operating conditions
- test the transmitter emergency stop and all warning devices prior to operation; testing should be done on each shift, without a load
- be thoroughly trained and knowledgeable in proper and safe operation of the crane, hoist, lifting device, or other material handling equipment that utilizes the radio control
- know how to keep the operator and other people clear of lifted loads and to avoid "pinch" points
- continuously watch and monitor status of lifted loads
- know and follow cable and hook inspection procedures
- know and follow the local lockout and tagout procedures when servicing radio controlled equipment
- know and follow all applicable operating and maintenance manuals, safety procedures, regulatory requirements, and industry standards and codes

The operator shall not:

- lift or move more than the rated load
- operate the material handling equipment if the direction of travel or function engaged does not agree with what is indicated on the controller
- use the crane, hoist or lifting device to lift, support or transport people
- lift or carry any loads over people
- operate the crane, hoist or lifting device unless all persons, including the operator, are and remain clear of the supported load and any potential pinch points
- operate a crane, hoist or lifting device when the device is not centered over the load

- operate a crane, hoist or lifting device if the chain or wire rope is not seated properly in the sprockets, drum or sheave
- operate any damaged or malfunctioning crane, hoist, lifting device or other material handling equipment
- change any settings or controls without authorization and proper training
- remove or obscure any warning or safety labels or tags
- leave any load unattended while lifted
- leave power on the radio controlled equipment when the equipment is not in operation
- operate any material handling equipment using a damaged controller because the unit may be unsafe
- operate manual motions with other than manual power
- operate radio controlled equipment when low battery indicator is on



THE OPERATOR SHOULD NOT ATTEMPT TO REPAIR ANY RADIO CONTROLLER. IF ANY PRODUCT PERFORMANCE OR SAFETY CONCERNS ARE OBSERVED, THE EQUIPMENT SHOULD IMMEDIATELY BE TAKEN OUT OF SERVICE AND BE REPORTED TO THE SUPERVISOR. DAMAGED AND INOPERABLE RADIO CONTROLLER EQUIPMENT SHOULD BE RETURNED TO MAGNETEK FOR EVALUATION AND REPAIR. FAILURE TO FOLLOW THIS WARNING COULD RESULT IN SERIOUS INJURY OR DEATH AND DAMAGE TO EQUIPMENT.

2.5 TRANSMITTER UNIT

Transmitter switches should never be mechanically blocked ON or OFF. When not in use, the operator should turn the transmitter OFF. A secure storage space should be provided for the transmitter unit, and the transmitter unit should always be placed there when not in use. This precaution will help prevent unauthorized people from operating the material handling equipment.

Spare transmitters should be stored in a secure storage space and only removed from the storage space after the current transmitter in use has been turned OFF, taken out of the service area and secured.

2.6 PRE-OPERATION TEST

At the start of each work shift, or when a new operator takes control of the equipment, operators should do, as a minimum, the following steps before making lifts with any crane or hoist:

Test all warning devices.

Test all direction and speed controls.

Test all functions

Test the transmitter emergency stop.

2.7 HANDLING BATTERIES



KNOW AND FOLLOW PROPER BATTERY HANDLING, CHARGING AND DISPOSAL PROCEDURES. IMPROPER BATTERY PROCEDURES CAN CAUSE BATTERIES TO EXPLODE OR DO OTHER SERIOUS DAMAGE. FAILURE TO FOLLOW THIS WARNING COULD RESULT IN SERIOUS INJURY OR DEATH AND DAMAGE TO EQUIPMENT.

Use only batteries approved by Magnetek for the specific product.

Do not dispose of a battery pack in fire; it may explode.

Do not attempt to open a sealed battery pack.

Do not short circuit the battery.

Keep the battery pack environment cool and dry during storage (i.e., not in direct sunlight or close to a heat source).

Do not submerge the battery pack or otherwise cause it to become wet.

2.8 OPTIONAL RECHARGABLE BATTERY CHARGING

For those transmitters equipped with rechargeable batteries and battery chargers, all users shall be familiar with the instructions of the charger before attempting to use.

Do not attempt to charge non-rechargeable battery packs in the charger.

Avoid charging partially discharged rechargeable batteries to help prolong battery cycle life.

Do not charge batteries in a hazardous environment.

Keep the battery pack environment cool during charging (i.e., not in direct sunlight or close to a heat source).

Do not short the charger.

Do not attempt to charge a damaged battery.

Use only Magnetek approved chargers for the appropriate battery pack.

Do not attempt to use a battery that is leaking, swollen, or corroded.

Charger units are not intended for outdoor use. Only use charger units indoors.

2.9 BATTERY DISPOSAL

Before disposing of batteries consult local and governmental regulatory requirements for proper disposal procedure.

3.0 FLEX VUE™ TRANSMITTER STANDARD CONFIGURATON AND OPERATION



BEFORE OPERATING THE TRANSMITTER, FAMILIARIZE YOURSELF WITH ALL SAFETY INFORMATION IN THIS MANUAL, THE CORRESPONDING RECEIVER SYSTEM MANUAL, APPROPRIATE MANUAL SUPPLEMENTS AND ANY OTHER LOCAL, STATE, OR FEDERAL RULES OR REGULATIONS ALREADY IN EXISTENCE. FAILURE TO FOLLOW THIS WARNING COULD RESULT IN SERIOUS INJURY OR DEATH AND DAMAGE TO EQUIPMENT.

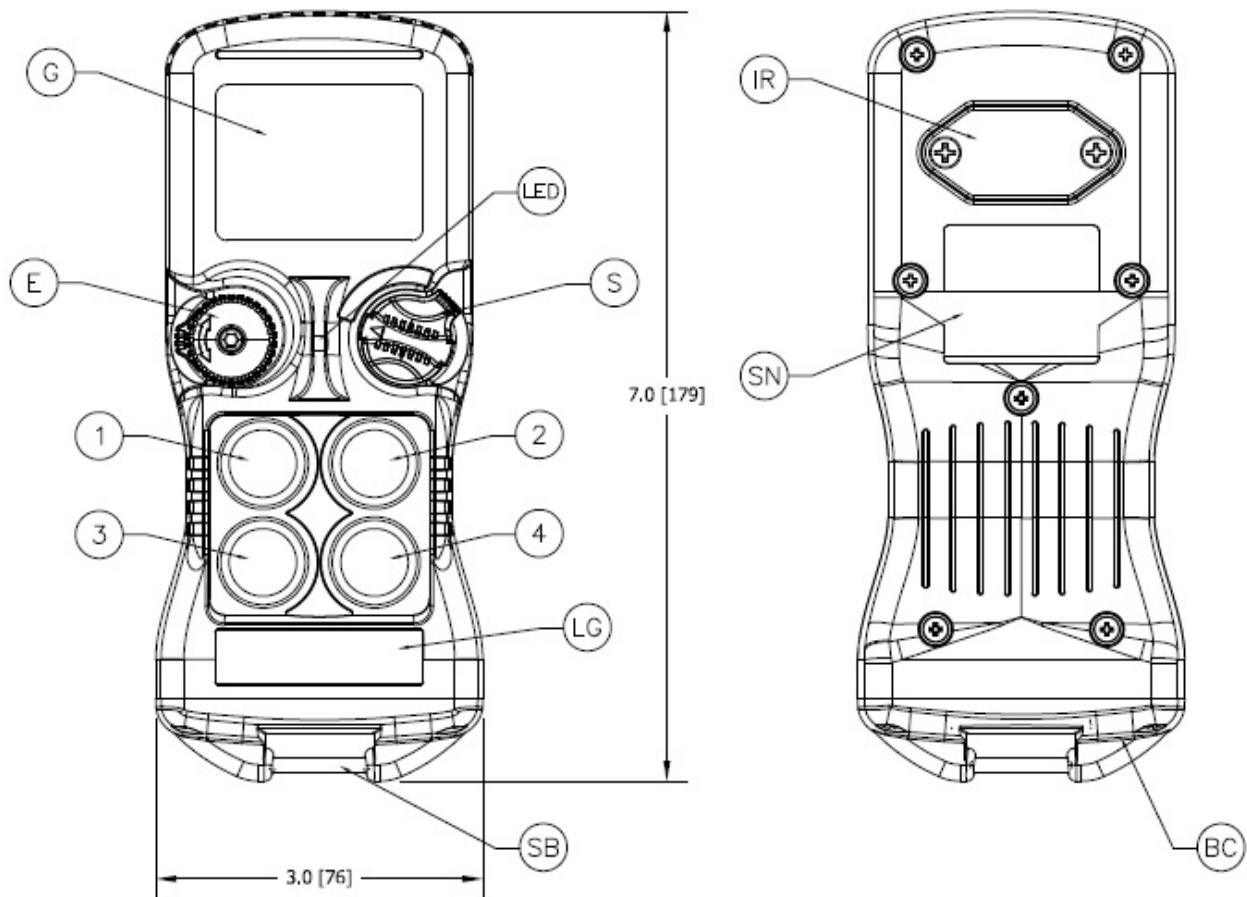

Figure 1: Typical Flex VUE™ 4 Button Configuration

G. Graphic Display

E. Machine Stop Button

LED. Status LED Indicator

S. Removable Power Key Switch

1. Pushbutton #1

2. Pushbutton #2

3. Pushbutton #3

4. Pushbutton #4

LG. Logo Label

SB. Strap Bar

IR. IR Communication Window

SN. System Information

BC. Battery Compartment

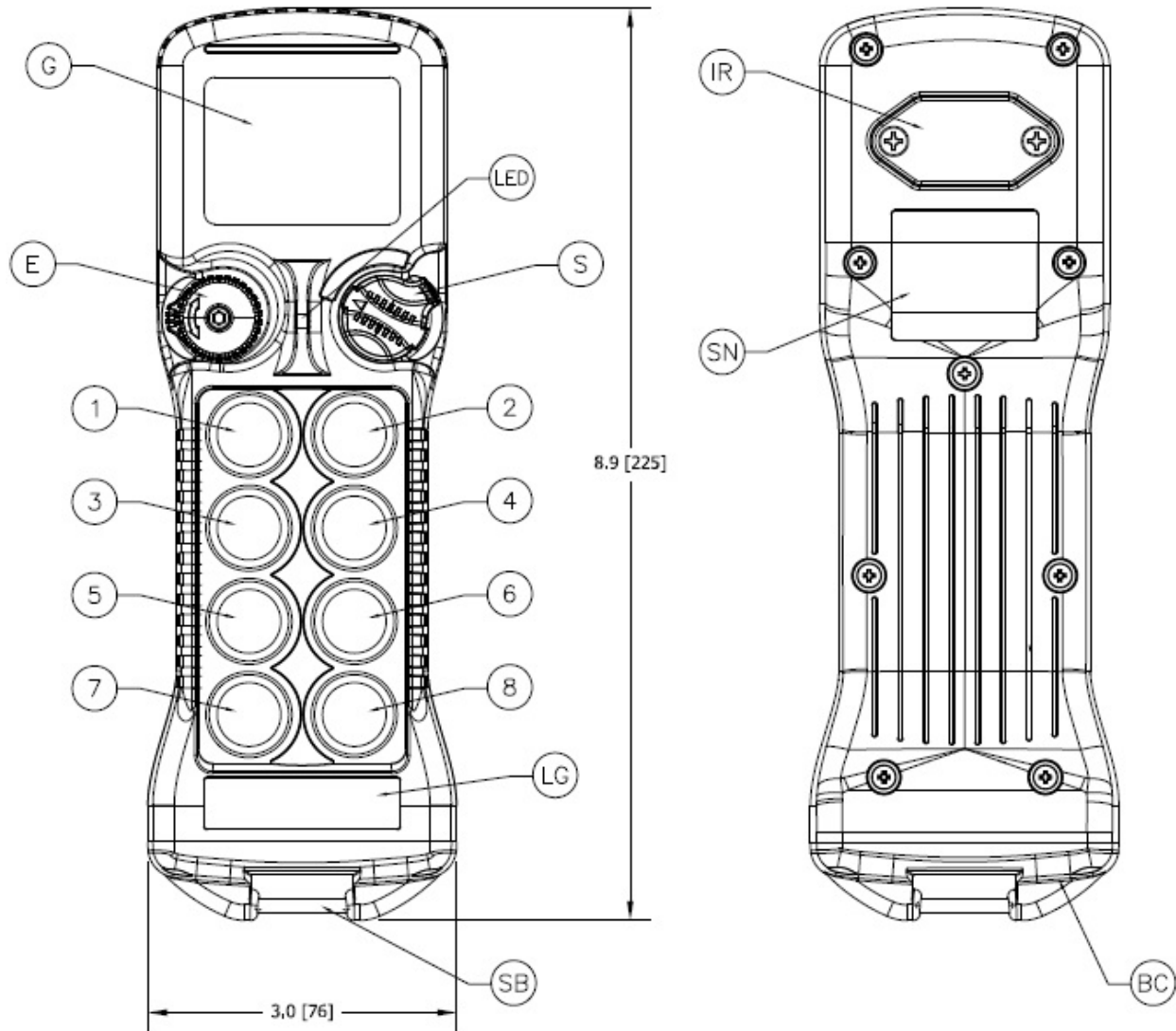

Figure 2: Typical Flex VUE™ 8 Button Configuration

G. Graphic Display

E. Machine Stop Button

LED. Status LED Indicator

S. Removable Power Key Switch

1. Pushbutton #1

2. Pushbutton #2

3. Pushbutton #3

4. Pushbutton #4

5. Pushbutton #5

6. Pushbutton #6

7. Pushbutton #7

8. Pushbutton #8

LG. Logo Label

SB. Strap Bar

IR. IR Communication Window

SN. System Information

BC. Battery Compartment

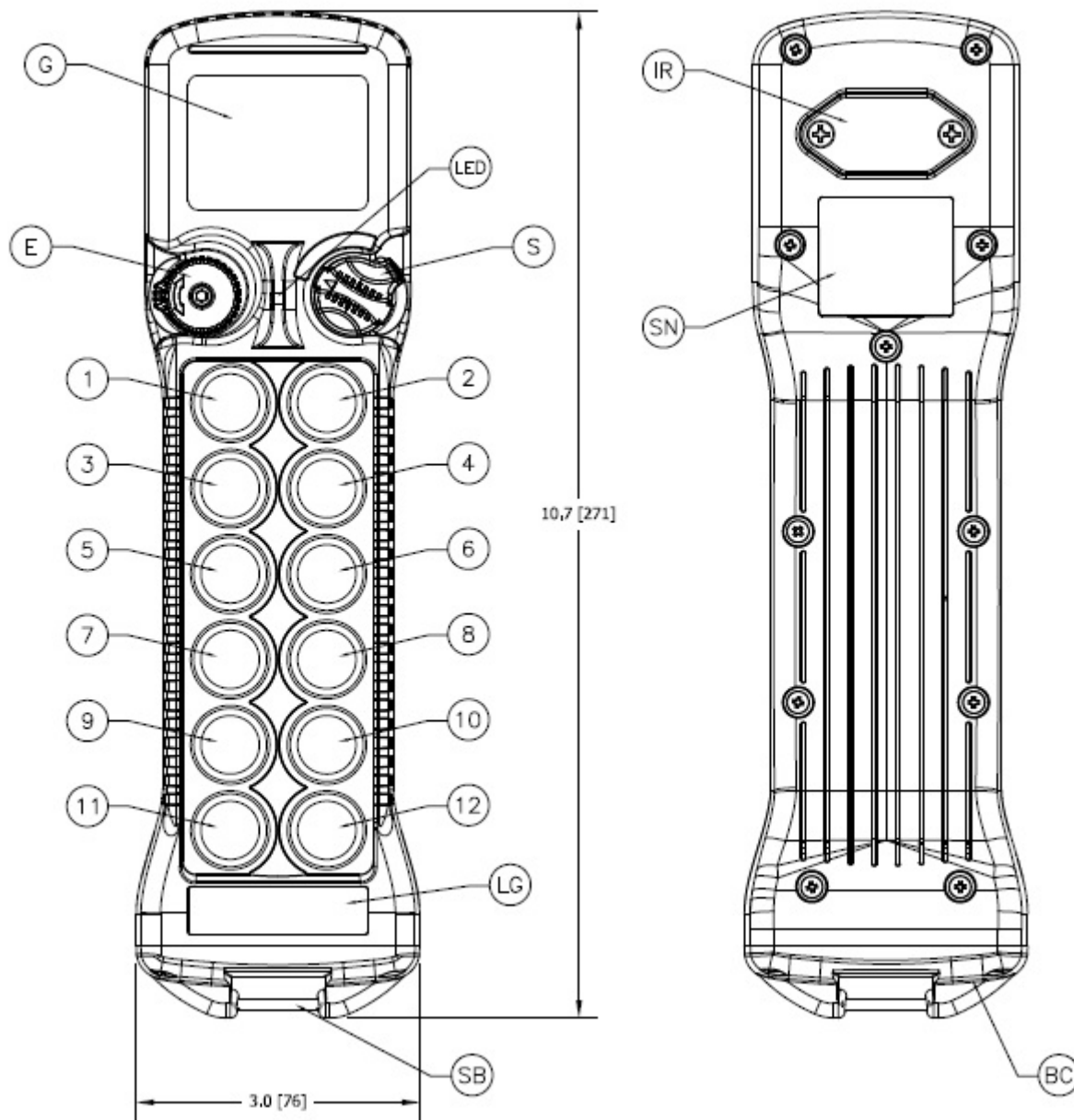

Figure 3: Typical Flex VUE™ 12 Button Configuration

G. Graphic Display

E. Machine Stop Button

LED. Status LED Indicator

S. Removable Power Key Switch

1. Pushbutton #1

2. Pushbutton #2

3. Pushbutton #3

4. Pushbutton #4

5. Pushbutton #5

6. Pushbutton #6

7. Pushbutton #7

8. Pushbutton #8

9. Pushbutton #9

10. Pushbutton #10

11. Pushbutton #11

12. Pushbutton #12

LG. Logo Label

SB. Strap Bar

IR. IR Communication Window

SN. System Information

BC. Battery Compartment

3.1 INSTALLING BATTERY COMPARTMENT

Prior to utilizing the Flex VUE™ transmitter, batteries must be installed.

3.1.1 Alkaline Battery Replacement

The Flex VUE™ comes standard with a removable battery compartment that holds two disposable AA alkaline batteries.



Figure 4: Flex VUE™ Alkaline Battery Compartment

To change the alkaline batteries in the battery compartment, separate the compartment from the outer housing (see Figure 4) by loosening all four screws (Phillips bit) on the battery compartment and replace the batteries with new ones. Orient the batteries according to the battery orientation diagrams on the inside of the battery compartment.



Figure 5: Separated Alkaline Battery Pack

When reinserting the compartment into the outer housing, make sure to align the compartment so that it fully seats. If the compartment will not seat, it is oriented upside down; flip the compartment over and it will fully seat. After fully seating the battery compartment into the outer housing, tighten the four screws on the outside edges of the compartment until the compartment is flush to the outside housing.

NOTE: Maximum torque for battery compartment screws should not exceed 5 in-lbs.



Figure 6: Installation of Battery compartment into Flex VUE™ transmitter

3.2 TURNING THE TRANSMITTER ON AND OFF

The Flex VUE™ uses both a three position rotary switch labeled either OFF-ON-START or OFF-ON-SPEED and a Machine Stop switch to turn the transmitter on or off.



Figure 7: Machine Stop Switch and OFF-ON-START/SPEED rotary

3.2.1 Turning On the Transmitter

First, the Machine Stop switch must be in the raised position or the pulled out position (see Section 3.3 for Machine Stop Switch operation).

Next, insert the black power switch key into the power key slot located on the right side of the transmitter just below the display. Rotate the key clockwise to the ON position, and the Magnetek logo will appear on the LCD screen. Following the logo screen, the unit will perform a routine initialization.



Figure 8: Machine Stop Switch and OFF-ON-START rotary

During initialization, the Flex VUE™ scans for any switches or motions that may be on during power up. If any switches or motions are on (with the exception of the OFF-ON-START rotary switch), the failure will be displayed on the screen, allowing you to recalibrate the switches if necessary. The Flex VUE™ will power down only if the switch fault is resolved with recalibration (see Section 3.2.2 on how to recalibrate the unit). The unit will need to be turned off if the switch fault cannot be resolved. See Section 3.2.4 for details on how to turn off the unit.

NOTE: If recalibrating the button does not fix the problem, then the button may be stuck or otherwise defective. Contact the factory for repair.

After a successful initialization, the Flex VUE™ will enter the Normal Operation Mode and display the normal operating screen. See Section 3.5 for more information on the Normal Operation Mode.

NOTE: Holding the OFF-ON-START rotary switch in the START position for more than five seconds during startup will put the device into Setup Mode. The START position is not required for turning on the transmitter for normal use.

3.2.2 Proportional Button Calibration

NOTE: On Flex VUE™ units equipped with 2-step buttons, calibration is not required.

The buttons on the Flex VUE™ are calibrated when the unit is assembled in the factory, but if the Flex VUE™ unit is experiencing problems, the buttons can be recalibrated after assembly by using the following procedure:

Proportional Buttons:

1. With the switch in the OFF position, press and hold Buttons 1 and 4 and turn the unit on. When the unit displays Button Calibration, release Buttons 1 and 4. The calibration numbers for each button will be displayed, showing the button number, the minimum value, and the maximum value (these are decimal values). The LED should be green.
2. Slowly press the button that needs to be calibrated. When the LED turns red, the minimum value can be set by putting the rotary switch into the START position. The LED should now be blue; release the rotary switch from the START position.
3. Press the current button all the way down to set the maximum value for the button. Release this button and repeat the process on any other buttons that need to be calibrated.
4. Once all of the buttons that need to be calibrated have been completed, hold the OFF-ON-START switch in the START position and push buttons 3 and 4. If the user does not want to save the new calibration information, then the OFF-ON-START switch can be turned to the OFF position to revert to the old calibration data.

After pushing the buttons, the user will then be prompted to release them. This will save the calibration data and put the unit back into normal operation.

3.2.3 Pulling In the Machine Stop Relay

Once the Flex VUE™ has been turned on (as described in Section 3.2.1) and is in the Normal Operating Mode, the Machine Stop relay in the receiver can be pulled in by turning the OFF-ON-START rotary switch to the START position and then releasing.

3.2.4 Turning Off the Transmitter

The transmitter can be turned off by rotating the OFF-ON-START switch to the OFF position. Once turned off, the Machine Stop relay in the receiver is immediately opened.

NOTE: During shutdown, the transmitter display will indicate that the shutdown sequence is being performed. Once the shutdown sequence is complete, the transmitter display will turn off.

NOTE: Depressing the Machine Stop switch will also turn the transmitter off and open the Machine Stop relay in the receiver. See Section 3.3 for more information on the Machine Stop switch.

3.2.5 Removing Power Switch Key

The black power switch key can be removed from the transmitter when not in use to prevent unauthorized use. To remove the power switch key from the transmitter, fully rotate the key counter-clockwise one click past the OFF position, and then pull the key straight out of the transmitter.

3.3 MACHINE STOP SWITCH (FOR EMERGENCY STOPPING ONLY)

The Machine Stop Switch is the red button located on the left side of the transmitter just below the display.

When the Machine Stop Switch is depressed, the Machine Stop relay in the receiver is immediately opened.

Under normal operating conditions, the Machine Stop Switch must be in the raised position or the transmitter and system will not operate.

To release the Machine Stop Switch, rotate the red button of the switch either clockwise or counterclockwise. The red button will pop up on its own when the button is rotated enough.

NOTE: The Machine Stop Switch is to be used for emergency stopping only, not for normal system shutdown.

3.4 USING PUSHBUTTONS FOR OPERATION

The Flex VUE™ units come equipped with either proportional push buttons for control or 2-step push buttons.

3.4.1 Proportional Push Button Control

On Flex VUE™ units equipped with proportional push buttons, the buttons can be set up to deliver a control signal output that increases in proportion to how far the push button is depressed.

NOTE: The proportional push buttons can be programmed at the factory to deliver a digital output for simple on/off commands.

3.4.2 2-Step Push Button Control

On Flex VUE™ units equipped with 2-Step push buttons, the buttons can be set up to deliver a control signal output that increases with each step that the button is depressed.

3.5 NORMAL OPERATING MODE – DISPLAY FEATURES/FUNCTIONS

In normal operating mode, the Flex VUE™ displays real time information relating to the operation of the transmitter on the graphic user interface. Information may include Command Confirmation, Battery Life, Signal Strength, Two-Way Feedback, etc.

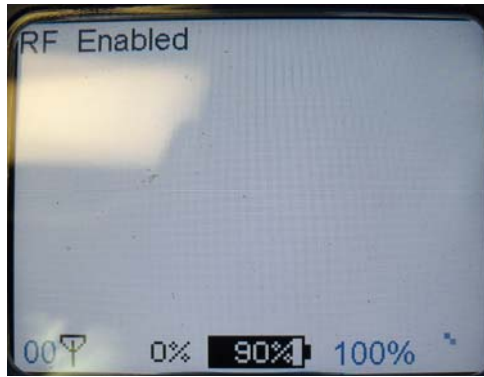

Figure 9: Normal operating screen on graphic user interface

3.5.1 Watch Dog Indicator (Sweeping Dot)

The Watch Dog Indicator is located on the far right of the bottom status line of the Flex VUE™ graphic user interface screen. The 4 pixel sweeping dot will start in the right corner of the screen, moving toward the upper left corner of the screen, stopping while still on the bottom line, and then return to the right corner of the screen. The watch dog indicator should always be moving, but will move at different rates depending on how much the transmitter is doing.

NOTE: The dot should be continuously sweeping at all times. If the dot is stationary (not sweeping), the transmitter needs to be power-cycled to operate properly.

3.5.2 Max Button Output Indicator (Percentage)

NOTE: This indicator is only present on Flex VUE™ units equipped with proportional buttons. Flex VUE™ units equipped with 2-step buttons will show no indication (the indication will be blank).

Located between the Watch Dog Indicator and the Battery Life Indicator on the bottom of the graphic user interface screen, this indicator shows the maximum value of the proportional button output. This value can be 25%, 50%, 75%, and 100%.

3.5.3 Battery Life Indicator

Remaining battery life is displayed in the bottom center of the graphic user interface screen.

Battery life is displayed in 10% increments.

3.5.4 Command Confirmation

Each time the user operates a control on the transmitter, a message will be displayed on the Flex VUE™ graphic user interface screen showing the operation defined in the transmitter (that relates to the receiver) and the value of the pushed button. This corresponds to the value being sent to the receiver.

For a 2-step button transmitter, if button number 2 is depressed fully, the display might show 'BTN2 Step 2', which translates to 'Button 2, speed 2' being sent to the receiver.

For a proportional button transmitter, the display might show "Boom Up: 85%", sending this message to the receiver to raise the boom at 85% of maximum rate.

3.5.5 Signal Strength Indicator

The Signal Strength Indicator is located on the bottom line of the Flex VUE™ graphic user interface screen, between the number of messages being received and the Battery Life Indicator.

The Signal Strength Indicator shows the radio signal strength at the receiver, and is only available in systems equipped for Two-Way feedback (see Section 3.5.6). For such systems, the signal strength being shown on the Flex VUE™ screen is the signal strength seen by the receiver.

NOTE: The signal strength indicator is only shown on systems that have two-way feedback enabled.

3.5.6 Two-Way Feedback System

This option allows the user to view various parameters that may be important to the operation of the equipment on the graphic user interface display screen.

Parameters such as engine RPM, the torque or speed of a drive, temperature, current, or any other useful values can be sent from the receiver and displayed on the transmitter.

3.6 NORMAL OPERATING MODE – STATUS LED INDICATIONS

In normal operating mode, the status LED will illuminate to provide instant feedback on the status of the Flex VUE™ transmitter.

The descriptions of the status LED illuminations are as follows:

- Flashing Green: Functioning normally
- Flashing Blue: Functioning normally and connected to receiver (only if two-way feedback is available and enabled)
- Flashing Red: Error or low battery (check display for details)

NOTE: Systems not configured for Two-Way feedback will not utilize the flashing Blue LED function.

4.0 TRANSMITTER SETUP

The transmitter may have settings changed in one of two ways: by using either the Setup Mode on the transmitter itself, or by connecting the transmitter to a computer and using the optional RCP software.

Configuration settings that can be changed are shown in Section 4.3.

All of the same settings can be changed with the optional RCP software.

4.1 USING THE TRANSMITTER IN SETUP MODE

The Setup Mode can be used to edit configuration settings; the values that can be changed are shown in Section 4.3. Some parameter changes will take effect immediately, while others will require a restart of the Flex VUE™ transmitter. This will be explained in Section 4.3.

4.2 ENTERING SETUP MODE

The Setup Mode can be entered in one of two ways, as explained in Sections 4.2.1 and 4.2.2.

If the password has been enabled, the password will need to be entered to get to the setup screen. The password is set to Enabled by default at the factory.

The factory default password is set to '0000'.

The value for the password can be changed once in the setup screen (Sections 4.3.8 and 4.3.9).

To enter the password, you need to press button 1 (to increment) or button 2 (to decrement) to change the password value. Once the value is set, press the START switch to move to the next entry position. Once the password is successfully entered the transmitter will show the setup screen.

NOTE: If the password is entered incorrectly, the device will display that the password is invalid and then exit out of the Setup Mode.

4.2.1 Entering Setup During Start Up

To enter the Setup Mode during startup of the transmitter, first make sure the unit is OFF and the Machine Stop Switch is raised. Next, turn the OFF-ON-START rotary switch clockwise to the START position and hold it there until the 'Entering Setup' screen appears. When the 'Entering Setup' screen appears, release the START switch. If password is enabled, it will need to be entered here.

In this mode, there will not be any information on the top line of the Flex VUE™ (since communication with the receiver has not yet been enabled). One of the setup parameters will be displayed on the screen, with 'Setup Mode' being displayed toward the bottom of the screen.

4.2.2 Entering Setup During Normal Operation

To enter the Setup Mode during normal operation of the transmitter, first make sure the unit is not controlling a device under load, as radio messaging will always be disabled during Setup Mode. Next, turn the OFF-ON-START rotary switch clockwise to the START position and hold it there, then depress buttons 1 and 2 (the top row of buttons) at the same time until the setup screen appears. If the password is enabled, it will need to be entered here.

In this mode, the top line of the display will show 'Com Disabled' to indicate that radio communication to the receiver had been initiated before Setup Mode was entered. Radio communication will be enabled after leaving Setup Mode. One of the setup parameters will be displayed on the screen, and 'Setup Mode' will be displayed toward the bottom of the screen.

4.3 ADJUSTING SETTINGS IN SETUP MODE

To navigate through Setup Mode, the buttons designated button 1 and button 2 (top row of buttons) and the OFF-ON-START switch are used. Buttons 1 and 2 cycle through the menus and are also used to change parameters within the menus. Rotating the OFF-ON-START switch to the START position will toggle between the menu and its parameter(s).

NOTE: No parameter changes will take effect until the user has selected 'Save and Exit' from the Setup Mode.

4.3.1 Access Code

The Access Code determines which receiver will be controlled by the transmitter.

The Access Code in the Flex VUE™ transmitter must match the receiver Access Code.

If the Access Code settings on the receiver and transmitter do not match, no communication will occur.

The Access Code is a 20-bit binary value with a decimal equivalent of 0 - 1048575.

If Setup Mode is entered using the sequence in Section 4.2.1, then the value entered into this parameter will be used after selecting 'Save And Exit' from the Setup Mode menu without having to restart the Flex VUE™. If Setup Mode was entered using the sequence in Section 4.2.2, then the Flex VUE™ will need to be power-cycled to start using the new parameter after 'Save And Exit' from the Setup Mode menu is selected.

4.3.2 Channel Select

The Channel Select setting determines the radio frequency that the Flex VUE™ is operating on.

The user can select from multiple channels within the base system frequency; the channel numbers and corresponding frequencies are listed in Sections 7.2 and 7.3.

If Setup Mode is entered using the sequence in Section 4.2.1, then the value entered into this parameter will be used after selecting 'Save And Exit' from the Setup Mode menu without having to restart the Flex VUE™. If Setup Mode was entered using the sequence in Section 4.2.2, then the Flex VUE™ will need to be power-cycled to start using the new parameter after 'Save And Exit' from the Setup Mode menu is selected.

4.3.3 RF Power

The RF Power setting determines the RF output of the transmitter.

The user can select values of "Min Power", "1/4 Power", "1/2 Power", and "Max Power".

If Setup Mode is entered using the sequence in Section 4.2.1, then the value entered into this parameter will be used after selecting 'Save And Exit' from the Setup Mode menu without having to restart the Flex VUE™. If Setup Mode was entered using the sequence in Section 4.2.2, then the Flex VUE™ will need to be power-cycled to start using the new parameter after 'Save And Exit' from the Setup Mode menu is selected.

4.3.4 Transmitter Inactivity Timeout

This setting controls the amount of time that the transmitter can be inactive before it automatically shuts off.

The Timeout time can be set from Disabled to 60 minutes. From Disabled to 15 minutes the timeout can be set in 1 minute increments. From 15 minutes to 60 minutes it can be set in 5 minute increments.

When the unit times out, the transmitter will turn off. The Flex VUE™ unit will need to be turned off and then back on to start the unit again.

If 'Save and Exit' is selected from the setup menu after changing this parameter, it will immediately take effect.



DO NOT ASSUME THE POWER IS OFF IN THE RECEIVER BECAUSE THE TRANSMITTER IS TURNED OFF. FAILURE TO FOLLOW THIS WARNING COULD RESULT IN SERIOUS INJURY OR DEATH AND DAMAGE TO EQUIPMENT.

4.3.5 Backlight Power %

The Backlight Power percentage setting controls the brightness of the backlight on the Flex VUE™ transmitter.

The Backlight Power can be set from 'Backlight Off' (0%) to 100%, in 5% increments.

If 'Save and Exit' is selected from the setup menu after changing this parameter, it will immediately take effect.

4.3.6 Backlight Timeout

The Backlight Timeout setting controls the amount of time that the backlight will stay on after a command is pressed before it automatically shuts off.

Backlight Timeout can be set from 'Always On' to 30 seconds, in 1 second increments.

If 'Save and Exit' is selected from the setup menu after changing this parameter, it will immediately take effect.

NOTE: Leaving the backlight on longer will decrease the battery run time and will require more frequent battery replacement.

4.3.7 Set Clock

This sets the system clock for the Flex VUE™ unit. The clock is set in the following format:

10/01/12 13:12:11
MM/DD/YY hh:mm:ss

If 'Save and Exit' is selected from the setup menu after changing this parameter, it will immediately take effect.

4.3.8 Password Enable

This setting enables or disables the requirement of entering a password into the transmitter to enter Setup Mode.

When the disabled setting is selected the user will go directly into Setup Mode without being prompted to enter a password.

Magnetek strongly recommends enabling the Setup Mode password to prevent unauthorized or accidental changes to parameters.

If 'Save and Exit' is selected from the setup menu after changing this parameter, it will immediately take effect.

NOTE: The unit is shipped with the password requirement enabled and utilizing the factory default password.

4.3.9 Change Password

This allows the user to change the password needed to enter the Setup Mode.

The password must consist of four digits.

If 'Save and Exit' is selected from the setup menu after changing this parameter, it will immediately take effect.

4.3.10 IR Configuration Receiver

The IR Cfg Recv function in the Setup Mode allows the transmitter to link to a compatible receiver by using IR (contact the factory to determine if your receiver is compatible), and automatically set up the channel and access code to match the linked compatible receiver.



THE IR CONFIGURATION FUNCTION WILL ONLY UPDATE CHANNEL AND ACCESS CODE INFORMATION IF THE RECEIVER AND TRANSMITTER ARE PROGRAMMED AT THE FACTORY WITH THE SAME PROJECT IDENTIFICATION NUMBER. IF THE RECEIVER/TRANSMITTER PAIRING IS NOT PROGRAMMED WITH THE SAME PROJECT IDENTIFICATION NUMBER, THE GRAPHIC USER INTERFACE WILL DISPLAY "ERR PROJECT ID" WHEN AN IR LINK IS ATTEMPTED. THE IR LINK WILL NOT BE SUCCESSFUL AND THE ACCESS CODE AND CHANNEL INFORMATION IN THE TRANSMITTER WILL NOT BE CHANGED.



WARNING

IF THE RECEIVER AND TRANSMITTER IR PAIR IS NOT OPERATING IN THE SAME FREQUENCY BAND WHEN AN IR LINK IS ATTEMPTED, THE GRAPHIC USER INTERFACE WILL DISPLAY “ERR RF FREQ”. THE IR LINK WILL NOT BE SUCCESSFUL AND THE ACCESS CODE AND CHANNEL INFORMATION IN THE TRANSMITTER WILL NOT BE CHANGED.

To utilize this feature, use the following steps:

1. Navigate to the menu function “IR Cfg Recv”.
2. Aim the IR window (on the back of the device) towards the IR window of the receiver.
3. Move the OFF-ON-START switch to the START position and release.
4. The user will then have 5 seconds to ensure the IR windows of the transmitter and receiver are lined up while the Flex VUE™ will countdown from five to zero.
5. After the countdown has reached zero, the interface will display “Attempting” while attempting to communicate with the receiver.
6. Upon successful communication with the receivers, the interface will display “Success”.
7. If the communication was unsuccessful, the interface will display “Failed”.

The interface may not display “Attempting” if the transmitter and receiver communicate successfully with each other upon their initial attempt.

NOTE: The changes to the transmitter’s channel configuration and access code will not be saved until the operator selects the ‘Exit with Save’ option to exit the Setup Mode.

If the receiver is not in range, the scan will time out and the graphic user interface will display “Failed.” The operator can reposition the transmitter and reattempt to establish the IR link with the receiver by toggling the START position on the OFF-ON-START switch multiple times.

NOTE: The access code and channel will not be updated to match the desired receiver until “Success” is displayed. Once “Success” is displayed, subsequent “Failed” messages will not overwrite the access code and channel obtained in the successful IR link until a new successful IR link is made.

4.3.11 Exit With Save

Selection of this option saves all changes and exits the Setup Mode.

4.3.12 Exit Without Save

If the user does not wish to save any of the configuration changes made, the ‘Exit Without Save’ option can be selected.

NOTE: None of the changes will be saved upon selection of this option. The transmitter will start up with the last saved configuration settings.

5.0 OPTIONAL PROGRAMMING WITH RCP

Using the optional RCP software makes programming of the Flex VUE™ easier and allows for settings to be saved for future reference.



WARNING

THE USE OF RCP (RADIO CONTROL PROGRAMMER) IS INTENDED FOR USE BY AUTHORIZED PERSONS ONLY. CHANGES TO ANY RADIO DATA VALUE MAY LEAD TO UNEXPECTED, UNDESIRABLE, OR UNSAFE OPERATION OF EQUIPMENT AND FURTHERMORE MAY LEAD TO EQUIPMENT DAMAGE, PERSONAL INJURY, OR EVEN DEATH. ALL EQUIPMENT OPERATORS AND/OR PERSONNEL SHOULD BE NOTIFIED OF ANY RADIO DATA VALUE CHANGES THAT MAY AFFECT OPERATION.

5.1 ACCESS CODES

The receiver and transmitter must be programmed with the same access code to properly communicate with each other.



WARNING

TWO OPERATIONAL TRANSMITTERS WITH THE SAME ACCESS CODES OPERATING AT THE SAME TIME IS A DEFINITE SAFETY HAZARD. FAILURE TO FOLLOW THIS WARNING COULD RESULT IN SERIOUS INJURY OR DEATH AND DAMAGE TO EQUIPMENT.

5.2 CONNECTING THE FLEX VUE™ TO A COMPUTER

The Flex VUE™ transmitter contains circuitry that permits communication with a computer system via USB. The USB mini-B plug is located through the battery compartment.



Figure 10: USB mini-B receptacle as viewed through the battery compartment

When plugging in the transmitter to a computer system, the transmitter battery compartment must be removed. The USB circuit provides power to the transmitter.

After plugging the USB cable in between the computer and the Flex VUE™, the OFF-ON-START switch needs to be moved to the ON position with the Machine Stop switch in the raised position to provide power to the transmitter.

5.3 PROGRAMMING WITH RCP

Read the section of the Flex VUE™ manual regarding additional operational features to become familiar with the features listed below. The Flex VUE™ transmitter can be programmed using the optional RCP (Radio Control Programmer) software.

Magnetek RCP software makes the programming of the Flex VUE™ transmitter easier and allows the programmer to store all of the Flex VUE™ settings in files for later use or reference. The RCP software also allows the programmer to customize the Flex VUE™ transmitter display with language descriptions that are project or machine specific. Help is provided for each function at the bottom of the RCP screen. The RCP software allows you to select radio channel, access code, transmitter power, etc. Follow the steps below:

Install the RCP Software

Install the RCP software onto your computer. The software is self-installing; simply insert the CD-ROM into your CD-ROM drive and follow the onscreen prompts. Refer to the installation instruction sheet for help. You will be prompted to enter an activation code. The code can be found on the CD jewel case and on the installation instructions. The software cannot be used without this code.

Run the RCP Software

After installation of the RCP Software, double click the RCP icon to launch the program.



Click on New Project or Open Project

Select “New Project” if you are creating a new program file. Select “Open Project” if you want to retrieve an existing program file. A list of recent projects will appear under “Open Project.” Clicking on one of these will open that project. It is recommended that you create a folder in which to save all programming files.

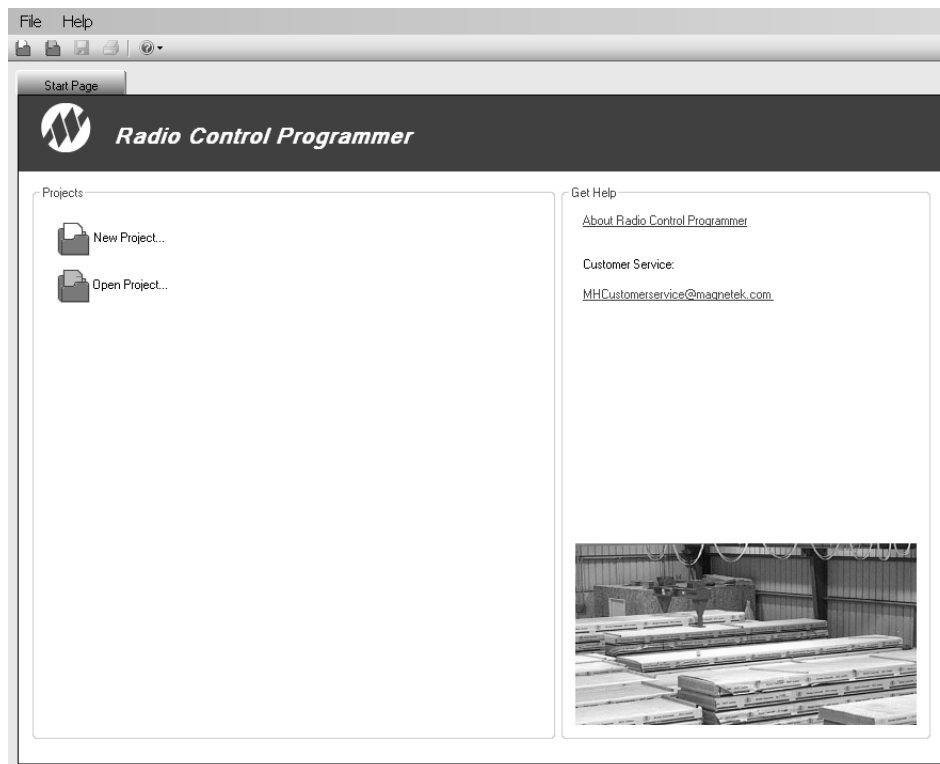

For New Projects, Select Device Type

After the New Project icon is selected, a menu will open listing the available device types. Select the device type that matches the product you wish to program (selecting a project type will display a picture of the product for verification).

Receive Device Data Checkbox

At the bottom of the New Project window there is a check box that allows the user to automatically download the setting values on the device upon connection.

NOTE: This check box is checked by default.

Having the “Receive Device Data” option checked will cause the program to automatically read the data that is currently on the device upon clicking the Add button.



WARNING

IF “RECEIVE DEVICE DATA” CHECK BOX IS UNCHECKED, THE RCP PROGRAM WILL OVERWRITE ALL SETTING VALUES ON THE DEVICE WITH DEFAULT VALUES AND ANY SETTINGS CHANGED BY THE OPERATOR UPON SENDING THE PROGRAM TO THE DEVICE. ALL STORED VALUE SETTINGS WITHIN THE DEVICE WILL BE REPLACED, INCLUDING ANY PROJECT-SPECIFIC VALUES. MAGNETEK STRONGLY RECOMMENDS THAT THE “RECEIVE DEVICE DATA” CHECK BOX BE LEFT CHECKED.

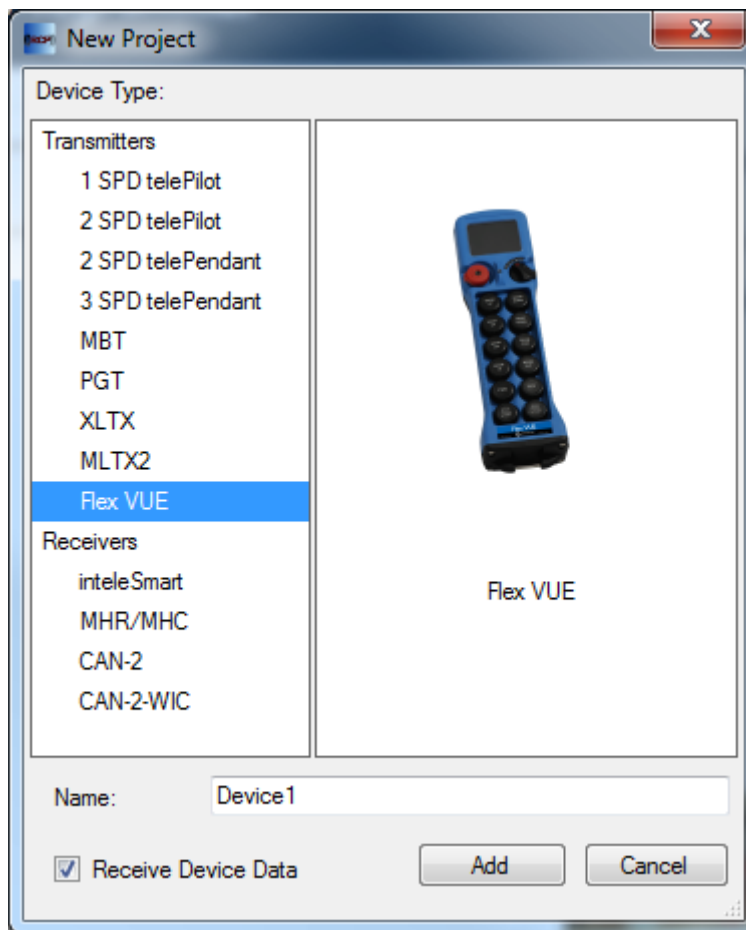

This screen also allows the programmer to create a specific name for the device to help keep track of device settings and changes. It is recommended that a unique name is chosen for each device programmed with RCP.

5.3.1 FLEX VUE™ Configuration Page

The Flex VUE™ Transmitter has one configurable page available to change settings on. The page allows the configuration of general transmitter settings (transmitter name, access code, RF channel, etc.).

Unit Info Page

This page allows the user to view the receiver's Project ID and serial number. The user can modify the transmitter name, access code, RF channel and activate the password. This page may also be used by the user to synchronize the internal clock on the transmitter with the connected PC or manually set the clock/date.

NOTE: Changing any of these details will require a reboot of the Flex VUE™ after the new information has been sent to the device.

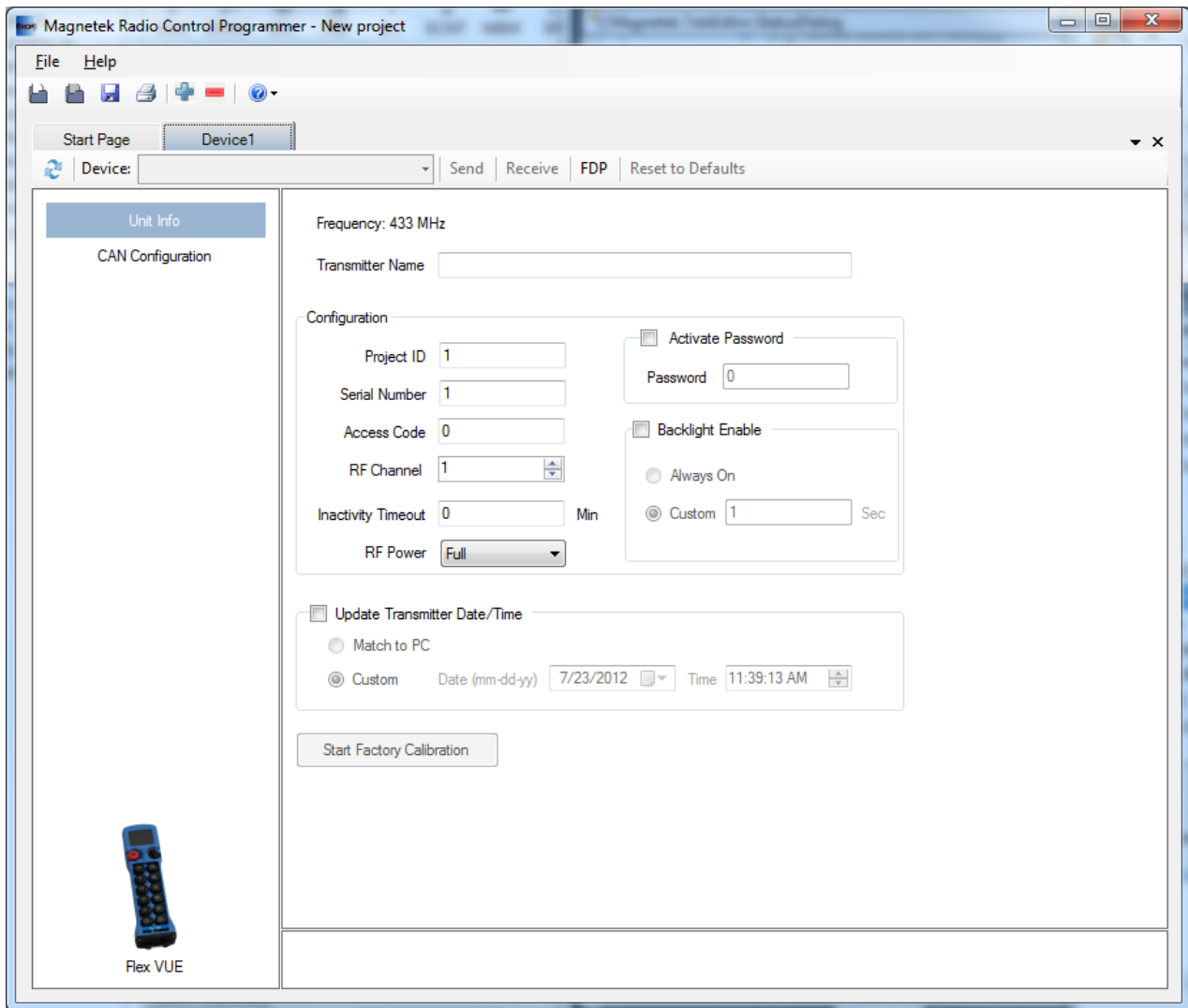

Transmitter Name

The transmitter name field allows the user to create a custom name for the transmitter. The name can be up to 16 ASCII characters long.

Project ID

This section displays the Project ID for the unit. The Project ID is set by the factory and cannot be modified by the user.

Serial Number

This section displays the serial number for the unit. The serial number of the unit is set by the factory and cannot be modified by the user.

Access Code

The access code acts as the transmitter address. The transmitter will only transmit commands to receivers with the same address. This feature is selectable by the user.

NOTE: The transmitter must be set with the same access code as the receiver to properly communicate with each other.



WARNING

THE ACCESS CODES IN THE RECEIVER ARE UNIQUE AND FACTORY PRESET. DO NOT CHANGE THESE ACCESS CODES UNLESS YOU ARE REPLACING AN EXISTING RECEIVER AND ITS ACCESS CODE. CHANGING THIS CODE COULD MAKE IT COMMON WITH ANOTHER RECEIVER ACCESS CODE, WHICH COULD MOVE OTHER EQUIPMENT. NO TWO SYSTEMS IN ANY LOCATION SHOULD EVER HAVE THE SAME ACCESS CODES INDEPENDENT OF FREQUENCY. FAILURE TO FOLLOW THIS WARNING COULD RESULT IN SERIOUS INJURY OR DEATH, AND DAMAGE TO EQUIPMENT.

RF Channel

The RF channel is user-selectable through the pull-down menu. This function is used to prevent interference with other radio devices. There are multiple user-selectable channels for 400 MHz, 900 MHz, and 2.4 GHz systems. See Sections 7.2 and 7.3 for channel frequency details.

Inactivity Timeout

The transmitter can be set to turn off after a period of time when no controls are activated. To restart the transmitter, the OFF-ON-START switch must be cycled through the START position. The factory default setting for the inactivity timeout is 15 minutes.

RF Power

The RF transmitting power of the unit is user-selectable through the pull-down menu. This function is used to reduce the operating range of the transmitter from the equipment being operated. The user-selectable options for RF power are Full, Half, Quarter, and Minimum.

Activate Password

The password is used to restrict access to the configuration menu on the Flex VUE™. Having an active password prevents accidental changes to the transmitter.

Please familiarize yourself with this section before programming the password.

If you choose to enable the password function, you can create a new password by selecting a four digit numerical password using numbers from 0 to 9. Be sure to write this password down in a safe place for future reference.



WARNING

ALWAYS REMEMBER TO STORE THE PASSWORD IN A SECURE LOCATION FOR ACCESS IF THE PASSWORD IS LOST OR FORGOTTEN. ONCE THE TRANSMITTER IS PROGRAMMED WITH A PASSWORD, THERE IS NO WAY TO DEFEAT THE PASSWORD WITHOUT USING THE RCP SOFTWARE TO EITHER READ THE PASSWORD OR REPROGRAM A NEW PASSWORD.



WARNING

THIS PASSWORD FUNCTION IS NOT TO BE USED AS A SECURITY DEVICE. THE PURPOSE OF THIS FUNCTION IS TO PREVENT ACCIDENTAL CHANGES TO THE TRANSMITTER SETTINGS. THE BEST FORM OF SECURITY IS ALWAYS TO LOCK UP THE TRANSMITTER WHEN NOT IN SERVICE. FAILURE TO FOLLOW THIS WARNING COULD RESULT IN SERIOUS INJURY OR DEATH AND DAMAGE TO EQUIPMENT.

The password default setting is to be disabled during initial programming by the RCP software. To enable password protection, check the box next to the phrase “Activate password.”



WARNING

NOT ENABLING THE PASSWORD FUNCTION ALLOWS THE TRANSMITTER SETTINGS TO BE MODIFIED BY ANY UNAUTHORIZED USERS. IMPROPER TRANSMITTER SETTINGS COULD RESULT IN SERIOUS INJURY OR DEATH AND DAMAGE TO EQUIPMENT.

Backlight Enable

This section allows the user to enable the LCD display backlight (on systems equipped with optional graphic user interface LCD display) and select the period of time after transmitter activity that the backlight stays on.

The user has the option to check the “Always On” check box for backlight timeout. If this box is checked, the backlight will remain on continuously while the transmitter is active.

NOTE: The longer the backlight is turned on, the shorter the transmitter battery life will be.

The user can also enable the backlight to turn off or timeout after a period of time, the user can select the custom field and enter in the time (in seconds) that the backlight should be lit. The range of values is 1 to 30 seconds.

Update Transmitter Date/Time

This feature allows the user to reset the internal clock on the transmitter to the correct date and time. The user can select to match the clock on the PC that is connected to the unit or select a custom date and time.

5.3.2 Saving, Downloading, and Reading the Programs and Other RCP Software Functions



CAUTION

TO PROGRAM OR READ DATA FROM THE FLEX VUE™, THE TRANSMITTER MUST BE TURNED ON.

Saving the Programming File

Once programming is complete click the file tab at the top of the RCP screen to open the file menu. File location and name can be selected from this menu. Old files can be deleted, called up, modified, and renamed by this same menu.

Sending a Program to the Flex VUE™



WARNING

AFTER EVERY PROGRAMMING OF THE TRANSMITTER, TEST THE UNIT BY UTILIZING THE APPROPRIATE RECEIVER. IF THE RECEIVER DOES NOT RESPOND, DO NOT ACTIVATE A FUNCTION BUTTON! THE TRANSMITTER MAY HAVE INCORRECT PROGRAMMING. RE-CHECK THE PROGRAMMING IN THE TRANSMITTER AND RETEST. AFTER ACTIVATION OF THE RECEIVER, FUNCTIONALLY TEST ALL COMMANDS ON THE TRANSMITTER BY INITIALLY JOGGING THE BUTTONS, THEN WITH A FULL MOVEMENT BEFORE RETURNING TO SERVICE. FAILURE TO FOLLOW THIS WARNING COULD RESULT IN SERIOUS INJURY OR DEATH AND DAMAGE TO EQUIPMENT.

To send a program file to a Flex VUE™ Transmitter

1. Plug in the USB programming cable.
2. Click the “send” button on the RCP screen. A dialog box will pop up confirming that you want to proceed. Check the box marked “I accept,” and then click the button “Continue send to radio.” On-screen prompts will confirm that the receiver has been programmed or if there are any issues.
3. Data will need to be sent separately for the Unit Info and CAN Configuration screens.

Receiving (Reading) the Flex VUE™ Programming

To read a program file from the Flex VUE™ Transmitter

1. Plug in the USB programming cable.
2. Click “Receive” and follow onscreen prompts.
3. RCP will confirm reception and automatically display current programming in the Flex VUE™ unit.

Reading the RCP Software Version

1. Select “Help”.
2. Select “About”.
3. The RCP Software Version number will be displayed.

Resetting Flex VUE™ Back to Factory Default Settings

1. Select “Reset to Defaults” button.
2. A dialog box will pop up confirming that you want to proceed. Click the button “OK” to restore the factory default settings. On-screen prompts will confirm that the transmitter has been reset to defaults or if there are any issues.
3. Power cycle the Flex VUE™ transmitter to implement the factory default values.

NOTE: Resetting the system back to factory defaults only restores the factory settings for the CAN configuration settings. All other settings will not be altered.

6.0 CLEANING THE TRANSMITTER

When cleaning the transmitter housing, a mild soap/detergent water solution should be used. After wiping the unit with this solution a clean water rinse should be done to remove any residue.

NEVER use the following to clean the transmitter:

- Cleaning fluids with ammonia (such as Windex or Formula 409)
- Gasoline
- Denatured Alcohol
- Carbon tetrachloride
- Acetone

Using any of the above items to clean the transmitter can cause damage to the transmitter and affect operation.

7.0 TRANSMITTER RF CHANNEL CONFIGURATION SETTINGS

The RF channel can be set via the Setup Mode or the optional RCP software. Sections 7.2 and 7.3 show the RF channels and protocols available for each transmitter radio frequency option.

7.1 FCC STATEMENTS

Compliance Statement (Part 15.19)

This device complies with Part 15 of FCC rules.

Operation is subject to the following two conditions:

1. This device may not cause harmful interference, and
2. This device must accept any interference received, including interference that may cause undesired operation.

Warning (Part 15.21)

Changes or modifications not expressly approved by the party responsible for compliance should void the user's authority to operate the equipment.

This portable transmitter with its antenna complies with FCC's RF exposure limits for general population/uncontrolled exposure.

7.2 CHANNEL AND FREQUENCY DESIGNATIONS BY COUNT

433 MHz: TMS

Channel Count	Channel Designator	Actual Frequency
01)	01	433.000 MHz
02)	02	433.050 MHz
03)	03	433.100 MHz
04)	04	433.150 MHz
05)	05	433.200 MHz
06)	06	433.250 MHz
07)	07	433.300 MHz
08)	08	433.350 MHz
09)	09	433.400 MHz
10)	10	433.450 MHz
11)	11	433.500 MHz
12)	12	433.550 MHz
13)	13	433.600 MHz
14)	14	433.650 MHz
15)	15	433.700 MHz
16)	16	433.750 MHz
17)	17	433.800 MHz
18)	18	433.850 MHz
19)	19	433.900 MHz
20)	20	433.950 MHz
21)	21	434.000 MHz
22)	22	434.050 MHz
23)	23	434.100 MHz
24)	24	434.150 MHz
25)	25	434.200 MHz
26)	26	434.250 MHz
27)	27	434.300 MHz
28)	28	434.350 MHz
29)	29	434.400 MHz
30)	30	434.450 MHz
31)	31	434.500 MHz
32)	32	434.550 MHz

Table 1.A

900 MHz: TMS

Channel Count	Channel Designator	Actual Frequency
01)	1	903.30 MHz
02)	2	906.30 MHz
03)	3	907.80 MHz
04)	4	909.30 MHz
05)	5	912.30 MHz
06)	6	915.30 MHz
07)	7	919.80 MHz
08)	8	921.30 MHz
09)	A	902.30 MHz
10)	B	904.10 MHz
11)	C	904.30 MHz
12)	D	905.10 MHz
13)	E	905.50 MHz
14)	F	905.70 MHz
15)	G	906.60 MHz
16)	H	908.70 MHz
17)	I	908.90 MHz
18)	J	909.10 MHz
19)	K	910.10 MHz
20)	L	910.70 MHz
21)	M	911.00 MHz
22)	N	911.20 MHz
23)	O	912.00 MHz
24)	P	914.20 MHz
25)	Q	914.40 MHz
26)	R	914.60 MHz
27)	S	914.80 MHz
28)	T	915.80 MHz
29)	U	917.40 MHz
30)	V	923.20 MHz
31)	W	927.00 MHz
32)	X	927.30 MHz

Table 1.B

7.3 OPTIONAL FREQUENCIES AND CHANNELS

7.3.1 2.4 GHz: FHSS

Channel sets are designated between 1 and 32. The frequency range is between 2402-2478 MHz. The frequency hopping protocol does not use one particular frequency to transmit a message. Messages are transmitted over multiple frequencies in a predefined sequence or channel set. In doing so, this protocol is able to compensate for interference that may be present on a single frequency by sending the message across multiple frequencies.

7.3.2 433 MHz Telemotive Legacy Channel Set: TMS

Channel Count	Channel Designator	Actual Frequency
01)	AK01	439.8 MHz
02)	AK02	439.6 MHz
03)	AK03	439.4 MHz
04)	AK04	439.2 MHz
05)	AK05	439.0 MHz
06)	AK06	438.8 MHz
07)	AK07	438.6 MHz
08)	AK08	438.4 MHz
09)	AK09	438.2 MHz
10)	AK10	438.0 MHz
11)	AK11	437.8 MHz
12)	AK12	437.6 MHz
13)	AK13	437.4 MHz
14)	AK14	437.2 MHz
15)	AK15	437.0 MHz
16)	AK16	436.8 MHz
17)	AK17	436.6 MHz
18)	AK18	436.4 MHz
19)	AK19	436.2 MHz
20)	AK20	436.0 MHz
21)	AKA00	433.125 MHz
22)	AKA01	433.325 MHz
23)	AKA02	433.525 MHz
24)	AKA03	433.725 MHz
25)	AKA04	433.925 MHz
26)	AKA05	434.125 MHz
27)	AKA06	434.325 MHz
28)	AKA07	434.525 MHz
29)	AKA08	434.725 MHz
30)	AK38	432.4 MHz
31)	AK50	430.0 MHz

Table 2

7.3.3 419 MHz Extended Channel Set: TMS

Channel Designator	Frequency	Channel Designator	Frequency
1*	418.950	44	417.500
2*	418.975	45	417.550
3*	419.000	46	417.600
4*	419.025	47	417.650
5*	419.050	48	417.700
6*	419.075	49	417.750
7*	419.100	50	417.800
8*	419.125	51	417.850
9*	419.150	52	417.900
10*	419.175	53	417.950
11*	419.200	54	418.000
12*	419.250	55	418.050
13*	419.275	56	418.100
14	416.000	57	418.150
15	416.050	58	418.200
16	416.100	59	418.250
17	416.150	60	418.300
18	416.200	61	418.350
19	416.250	62	418.400
20	416.300	63	418.450
21	416.350	64	418.500
22	416.400	65	418.550
23	416.450	66	418.600
24	416.500	67	418.650
25	416.550	68	418.700
26	416.600	69	418.750
27	416.650	70	418.800
28	416.700	71	418.850
29	416.750	72	418.900
30	416.800	73	419.350
31	416.850	74	419.400
32	416.900	75	419.450
33	416.950	76	419.500
34	417.000	77	419.550
35	417.050	78	419.600
36	417.100	79	419.650
37	417.150	80	419.700
38	417.200	81	419.750
39	417.250	82	419.800
40	417.300	83	419.850
41	417.350	84	419.900
42	417.400	85	419.950
43	417.450		

Table 3

*NOTE: Channels marked with * are approved for use in China*

8.0 TROUBLESHOOTING

8.1 GENERAL TROUBLESHOOTING

Problems	Possible Reasons	Suggestions
Transmitter will not turn on	Batteries are dead or installed backwards; battery holder is damaged.	Replace the batteries and confirm they are installed according to the polarity markings in the battery pack. Inspect all battery pack contacts for damage.
	Transmitter is failing switch scan.	Be sure all switches and motions are in the off position on startup. See Section 3.2 for more info.
	Transmitter Machine Stop Switch is down or pressed.	Be sure the Machine Stop switch is pulled up.
Transmitter will not respond with the receiver	Incorrect system RF channel.	Make sure the transmitter and receiver unit are both set to the same RF channel. See Section 4.3.
	Incorrect system access code.	Make sure the transmitter and receiver both have the same access code. See Section 4.2.1.
	System out of range.	Make sure that the startup procedure is initiated within 300 feet from the receiver location. If equipped with the Signal Strength Indicator, make sure the level is greater than 0%.
	The antenna on the receiver is missing, damaged, or improperly installed.	Inspect the antenna on the receiver for damage and try to locate the antenna in a location that is visible when operating the equipment at all times.

8.2 ASSEMBLY AND REPLACEMENT PARTS

If your transmitter ever needs repair, we always recommend that you have Magnetek perform the repair. There are no user serviceable parts within the Flex VUE™. Please contact Magnetek's service department at +1.866.MAG.SERV for information regarding parts and service.

9.0 EU DECLARATION OF CONFORMITY



MAGNETEK

EU Declaration of Conformity Certificate

For the following equipment:

Product : FlexVUE Series Radio Remote Control
Manufacturer's Name : Magnetek, Inc.
Manufacturer's Address : N49 W13650 Campbell Drive
Menomonee Falls, WI 53051 USA

The undersigned hereby declares on behalf of Magnetek, that the above-referenced products, to which this declaration relates, is in conformity with the provisions of CE Mark Directive (93/68/EEC), Machinery Safety Directive (MD) 2006/42/EC, Low Voltage Directive (LVD) 2006/95/EC, and Radio and Telecommunications Equipment Directive (R&TTE) 1999/5/EC.

The standards relevant for the evaluation of the product referenced above conformity to the directive requirements are as follows:

EN 301 489-1	EN 60204-32
EN 301 489-3	EN 60950-1
EN 301 220-3	EN ISO 13849-1
EN 60204-1	EN 13557

The European contact for Magnetek is:

Brian Preston
Magnetek
Unit 3, Bedford Business Centre
Mile Road
Bedford
MK42 9TW
United Kingdom

Per Annex II.B of the Machinery Directive (2006/42/EC):

The machinery, product, assembly or sub-assembly covered by this Declaration of Conformity must not be put into service until the machinery into which it is to be incorporated has been declared in conformity with the provisions of the applicable Directive(s). This statement is only necessary where the product is to be incorporated into a machine or system (e.g. a safety component).

Signature of Authorized Person:

Ben Stoller / Director - Radio Controls
For Magnetek, Inc.
Menomonee Falls, WI USA

June 3, 2013

Date of Issuance