



LaserGuard2

Laser Collision Avoidance System



MAGNETEK
MATERIAL HANDLING

Part Number: 147-20004 R2
October 2015

©Copyright 2015 Magnetek Material Handling

Table of Contents

Service Contact Information	3
1. Preface and Safety	4
1.1. Product Safety Information.....	4
1.2. Product Warranty Information	4
1.3. DANGER, WARNING, CAUTION, and NOTE Statements.....	5
1.4. Collision Avoidance Unit Warnings	6
2. General System Information	7
2.1. LaserGuard2 Model Numbers.....	7
2.2. Class 1 Laser Device	7
2.3. Laser Collision Avoidance System Description.....	7
2.4. Optical Path Fault Detector	8
2.5. Fault Relay	8
2.6. System Specifications	9
3. Installation Information.....	10
3.1. Mounting Location Considerations.....	10
3.2. Line Input Considerations	10
3.3. Wiring Considerations	10
3.4. Mechanical Installation	11
3.5. Electrical Installation	20
3.6. Mechanical Alignment	24
3.7. Range Detector Settings.....	24
3.8. Fault Check	24
3.9. Troubleshooting.....	25
4. Installation Diagrams	27

Service Contact Information

For questions regarding service or technical information contact:

1-866-MAG-SERV
(1-866-624-7378)

Magnetek Material Handling
N49 W13650 Campbell Drive
Menomonee Falls, WI 53051

Telephone: 800-288-8178

Website: www.magnetek.com
E-mail: MHcustomerservice@magnetek.com

Fax Numbers:

Main: 800-298-3503
Sales: 262-783-3510
Service: 262-783-3508

Magnetek, Inc. has additional satellite locations for Canada and the United States. For more information, please visit <http://www.magnetek.com>.

©2015 MAGNETEK

All rights reserved. This notice applies to all copyrighted materials included with this product, including, but not limited to, this manual and software embodied within the product. This manual is intended for the sole use of the person(s) to whom it was provided, and any unauthorized distribution of the manual or dispersal of its contents is strictly forbidden. This manual may not be reproduced in whole or in part by any means whatsoever without the expressed written permission of MAGNETEK.

1. Preface and Safety

©2015 MAGNETEK

All rights reserved. This notice applies to all copyrighted materials included with this product, including, but not limited to, this manual. This manual is intended for the sole use of the persons to whom it was provided, and any unauthorized distribution of the manual or dispersal of its contents is strictly forbidden. This manual may not be reproduced in whole or in part by any means whatsoever without the expressed written permission of Magnetek.

1.1. Product Safety Information

Magnetek, Inc. (Magnetek) offers a broad range of radio remote control products, control products and adjustable frequency drives, industrial braking systems, and power delivery products for material handling applications. This manual has been prepared by Magnetek to provide information and recommendations for the installation, use, operation and service of Magnetek's material handling products and systems (Magnetek Products). Anyone who uses, operates, maintains, services, installs or owns Magnetek Products should know, understand and follow the instructions and safety recommendations in this manual for Magnetek Products.

The recommendations in this manual do not take precedence over any of the following requirements relating to cranes, hoists, lifting devices or other equipment which use or include Magnetek Products:

- Instructions, manuals, and safety warnings of the manufacturers of the equipment where the Magnetek Products are used,
- Plant safety rules and procedures of the employers and the owners of the facilities where the Magnetek Products are being used,
- Regulations issued by the Occupational Health and Safety Administration (OSHA),
- Applicable local, state, provincial, or federal codes, ordinances, standards and requirements, or
- Safety standards and practices for the industries in which Magnetek Products are used.

This manual does not include or address the specific instructions and safety warnings of these manufacturers or any of the other requirements listed above. It is the responsibility of the owners, users and operators of the Magnetek Products to know, understand and follow all of these requirements. It is the responsibility of the employer to make its employees aware of all of the above listed requirements and to make certain that all operators are properly trained.

No one should use Magnetek Products prior to becoming familiar with and being trained in these requirements and the instructions and safety recommendations for this manual.

1.2. Product Warranty Information

Magnetek, hereafter referred to as Company, assumes no responsibility for improper programming or installation of a device (such as a drive or radio) by untrained personnel. A device should only be programmed/installed by a trained technician who has read and understands the contents of the relevant manual(s). Improper programming/installation of a device can lead to unexpected, undesirable, or unsafe operation or performance of the device. This may result in damage to equipment or personal injury. Company shall not be liable for economic loss, property damage, or other consequential damages or physical injury sustained by the purchaser or by any third party as a result of such programming or installation. Company neither assumes nor authorizes any other person to assume for Company any other liability in connection with the sale or use of this product.

For information on Magnetek's product warranties by product type, please visit www.magnetek.com.

1.3. DANGER, WARNING, CAUTION, and NOTE Statements

Read and understand this manual before installing, operating, or servicing this product. Install the product according to this manual and local codes.

The following conventions indicate safety messages in this manual. Failure to heed these messages could cause fatal injury or damage products and related equipment and systems.



DANGER

DANGER indicated an imminently hazardous situation which, if not avoided, will result in death or serious injury. This signal word is to be limited to the most extreme situations.



WARNING

WARNING indicates a potentially hazardous situation which, if not avoided, could result in death or serious injury.



CAUTION

CAUTION indicates a potentially hazardous situation which, if not avoided, could result in minor or moderate injury. It may also be used to alert against unsafe practices.

NOTE: A NOTE statement is used to notify installation, operation, programming, or maintenance information that is important, but not hazard-related.

1.4. Collision Avoidance Unit Warnings



WARNING

Range detector relays should never be electrically or mechanically disabled to be ON or OFF for any crane motion. If the unit is for any reason disengaged or turned off the crane operating personnel must be notified immediately, and proper alternate precautions should be taken.



WARNING

The crane collision avoidance unit and limit switches, if any, should be checked at the beginning of each shift or when a new operator takes control of the crane. When checking the collision avoidance unit and limit switches the hoist should be centered over an area free of personnel and equipment.



WARNING

The collision avoidance unit and limit switches should never be used as a regular stopping device. They are intended to be protective devices.

2. General System Information

2.1. LaserGuard2 Model Numbers

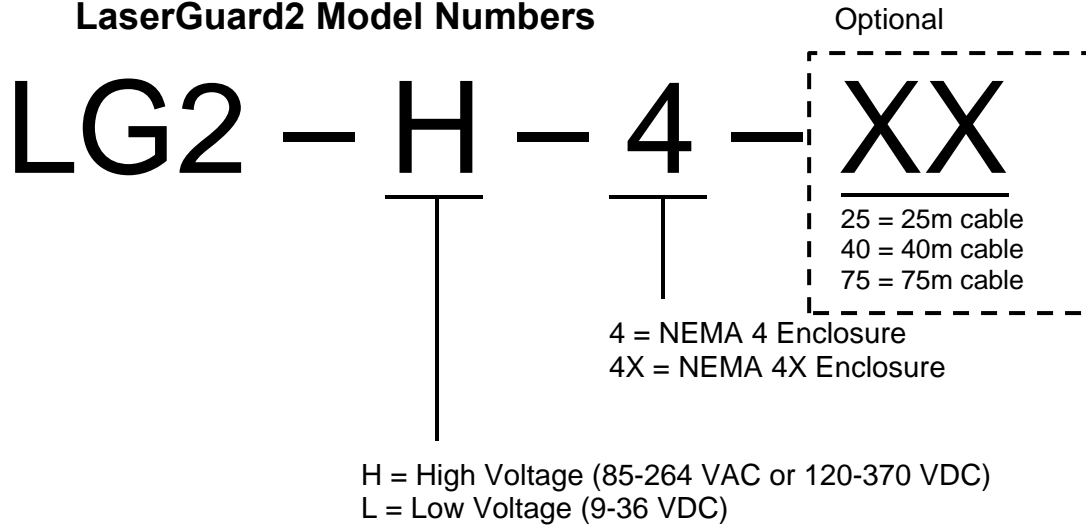

2.2. Class 1 Laser Device

The Magnetek Collision Avoidance System contains a Class 1 laser with a 660 nm wavelength. Although the laser is eye-safe, it is recommended that no one look directly into the laser with their eye close to the lens of the laser unit. Do not open the laser unit to service it since there are no serviceable parts inside.

2.3. Laser Collision Avoidance System Description

Magnetek's Collision Avoidance System measures the distance between the laser unit's lens and its companion retro-reflective target by means of pulse ranging technology that allows for very accurate measurements and energy efficiency. The laser communicates with the Laser Support Unit (LSU) by means of a 4 mA to 20 mA current loop. This type of communications link has very high noise immunity and provides the necessary accuracy for a collision avoidance system. The laser used in the LaserGuard2 system is set to measure distances from 8 in. to 150 ft. with an output current of 4 mA at 8 in. and 20 mA at 150 ft. The laser has a visible light beam, which makes system alignment very easy. On the front and top of the laser are two LEDs; these LEDs indicate power and alignment. A steady green light indicates power to the laser. In the event of a laser short circuit, that green LED will flash at 4Hz. An amber light indicates the target is acquired and reading a signal.

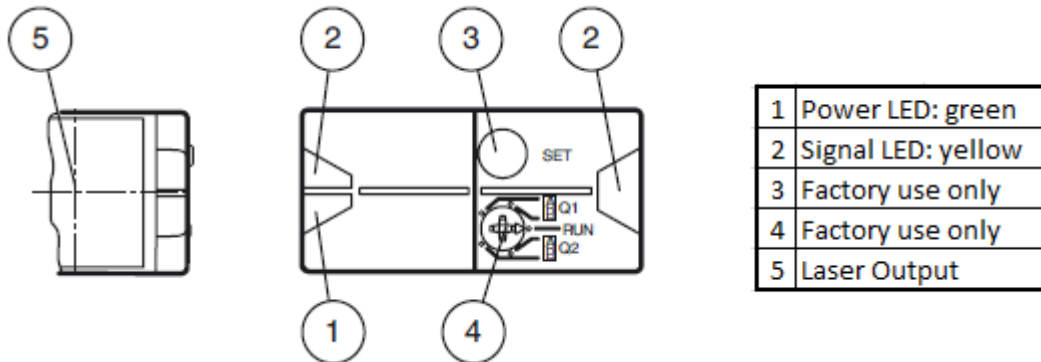

Figure 1: Laser Optical Unit

A rugged, fully adjustable mount is also supplied with the system, along with a reflective target. The target is mounted on the wall or other crane that is going to be protected by the collision avoidance system.

The LSU contains three fully adjustable range detectors and a fault detector. The range detectors are adjustable to trip the relays from approximately 8 in. to 150 ft., where the warning detector is set for the distance that the warning should appear at, or where the first stage of crane deceleration takes place. Slowdown sets stage two of deceleration, and the third detector is used to set the point where the crane brakes should be applied. The relationship between these points is as follows:

150 ft. \geq Warning > Slowdown > Stop \geq 8 in.

If the above sequence is not maintained, an out-of-sequence error will occur, which will drop out all range points and the fault detector. This will stop the crane and prevent it from being moved in the protected direction until the sequence is corrected. The FAULT LED (DS5) will flash three times, pause, and repeat until the sequence is in the correct order.

2.4. Optical Path Fault Detector

When the system detects a loss in the optical path due to obstructions or misalignment of the laser and its target, it will produce a 10 second fault. This will cause the fault relay and the range point relays to drop out for 10 seconds. After this 10-second period, the system will return back to normal operation until the fault is detected again. If the laser beam is continuously lost or blocked, the controls will act as if the laser is out of range and allow the operator to run at full speed after the 10-second period. This is the only fault condition that lasts 10 seconds (all other fault conditions do not time out), thereby making it easy to determine that an optical path problem has occurred and maintenance is needed to tighten or realign the laser mounting and/or the reflector.

2.5. Fault Relay

A separate form C relay is provided to drive a warning light or enunciator in the event of a fault. The relay is normally energized and if a fault occurs the relay switches. Faults include the loss of the target, setting out of sequence, undercurrent, or overcurrent.

2.6. System Specifications

Specification	Laser	Laser Support Unit (LSU)			
		LG2-H-4	LG2-L-4	LG2-H-4X	LG2-L-4X
Operating Temperature	-30° to 55°C	-30° to 70°C			
Operating Range	8 in.-150 ft.	--	--	--	--
Input Voltage	--	85 - 264 VAC or 120 - 370 VDC	9-36 VDC	85 - 264 VAC or 120 - 370 VDC	9-36 VDC
Accuracy	1 in.	--			
Hysteresis	--	Approx. 12"			
Control Outputs	--	Three form C relays rated at 10 A, 270 VAC, and 27 VDC			
Fault Output	--	One form C relay rated at 10 A, 270 VAC, and 27 VDC			
Laser Class	1	--			
Wavelength	660 nm				
Ambient Light Limit	50000 Lux	--			
Enclosure (Standard)	Plastic IP65	NEMA 4		NEMA 4X	
Unit Dimensions	4.0" x 2.1" x 1.0"	Approx. 11.8" x 9.8" x 5.9"			
Weight	0.2 lbs.	Approx. 12.2 lbs.			
Reflector Dimensions	2' x 2'	--			
Cable Length	32.8 ft. (standard)	--			

3. Installation Information

NOTE: In the event that parts of an original LaserGuard system are used with the LaserGuard2, please refer to the LaserGuard2 Replacement Guide Application Bulletin on <http://www.magnetek.com>.



CAUTION

THE LASER CONTROL UNIT AND RELAYS ARE NOT RATED AS EXPLOSION PROOF. THE UNIT MUST NOT BE INSTALLED IN EXPLOSIVE ENVIRONMENTS UNLESS APPROPRIATE SECONDARY ENCLOSURE MEASURES ARE TAKEN.

3.1. Mounting Location Considerations

Ensure the mounting location is as far as possible from exposed trolley wires and sources of electromagnetic or radiated noise.

If possible, avoid installing the receiver unit to a surface where high vibration or shock is present. If this cannot be avoided, use appropriate shock mounts.

3.2. Line Input Considerations

Check the system drawings for proper line input voltage. If there is any question as to proper line input voltage, contact Magnetek before applying power to the unit.



WARNING

THE UNIT MUST BE WIRED TO THE CORRECT VOLTAGE. FAILURE TO DO SO MAY DAMAGE THE SYSTEM.

NOTE: The unit should not be connected to lines containing excessive power up transients or continuous commutator noise. A line conditioner may be necessary in some installations.

3.3. Wiring Considerations

1. Do not connect or disconnect wiring or perform circuit checks while the power is turned on.
2. The motor wiring shall be in a separate metal conduit from the power wiring, which shall also be in a metal conduit.
3. Low voltage wires shall be wired with Class 1 wiring.
4. Control wiring shall be in separate conduit, and shall be kept as short as possible.
5. Control wiring for stepless devices shall be shielded twisted pair. The shield should be grounded at both ends.
6. All terminals shall be tightened to a specified terminal torque (8.8 in-lbs. unless otherwise specified).
7. Please observe National Electric Code (NEC) when wiring electrical devices.
8. When cutting holes in the cabinet, take care to prevent metal filings from shorting the circuitry. Remove excess metal screws, metal filings, and wire clippings from inside of the unit.
9. Inspect to make sure no exposed wire has contact with any other wiring or terminals.
10. Suppressors are strongly recommended on all contactors.

3.4. Mechanical Installation

The Collision Avoidance System measures the distance between the laser unit's lens and the target surface. There must be no projections on the wall or the overhead crane that may extend in front of either (or both) the laser unit or the companion target.

Make sure the laser is mounted such that nothing can come between the laser's view of the target.

Determine the mounting position for the laser and the target such that the center of the laser's faceplate and the center of the target are the same distance above the plane the crane rails are in. The laser and target center point should also be the same distance from the rails. This is the most important part of a successful installation since the laser beam must stay on the target at all range points anywhere in the bay. Refer to Figure 4 for mounting information.

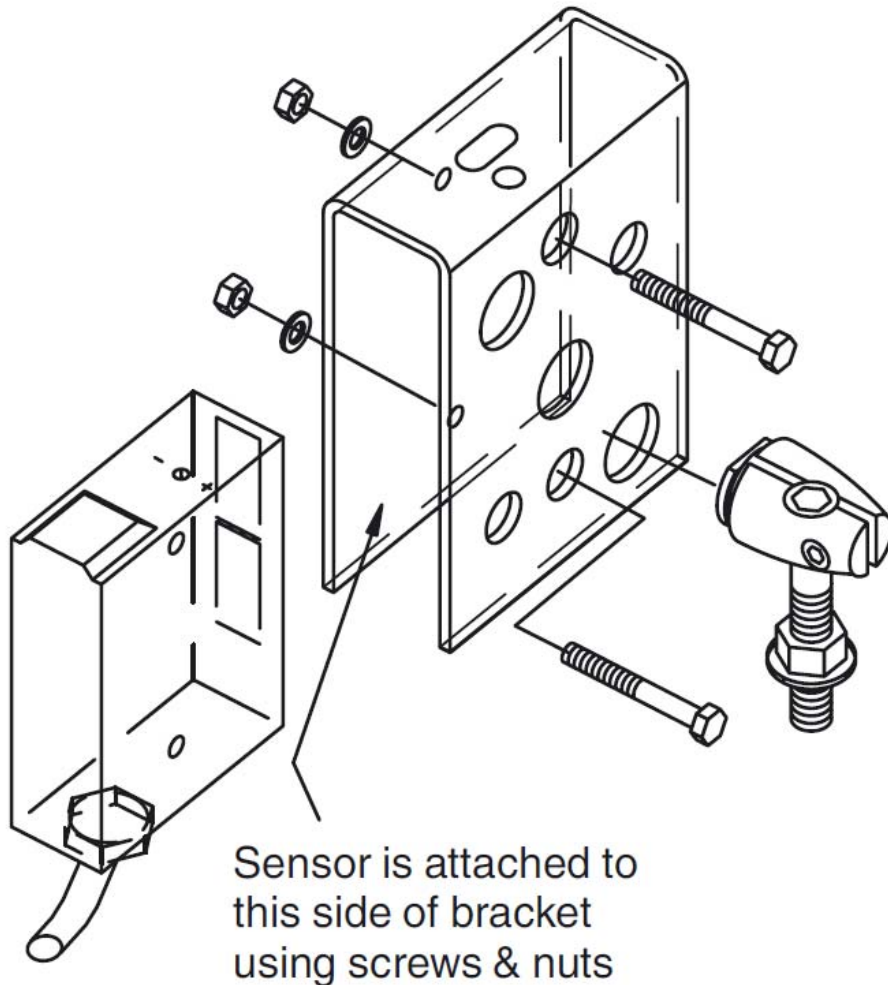

Figure 2: Laser Optical Unit and Mounting Assembly for LG2-x-4 Systems

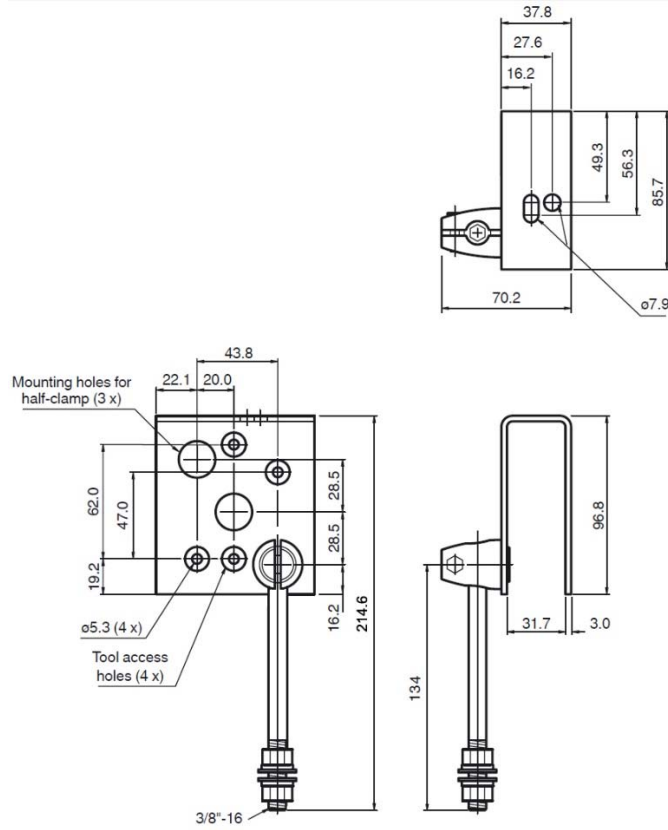
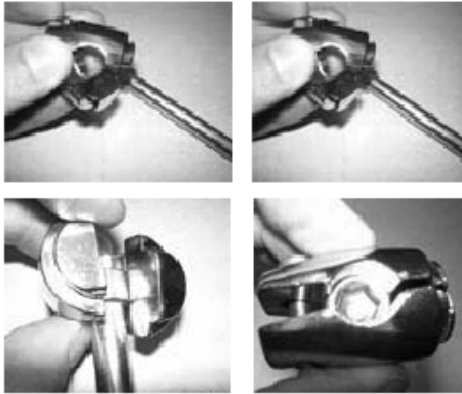

Figure 3: Laser Mounting Bracket Dimensions for LG2-x-4 Systems (in mm)



Step 1

To assemble, the sensor must be mounted inside the sensor shroud. Slide the two screws through the shroud and sensor with the two washers and two nuts on the outside of the shroud. Tighten the screws in place.



Step 2

Loosen the half-clamp and observe the grooved slot inside. Place the head of the mounting bolt/rod into this groove.

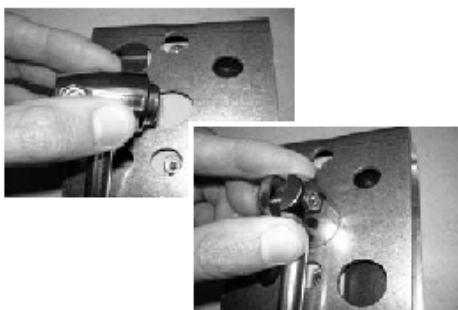

Step 3

Without tightening the half-clamp over the bolt head, squeeze the clamp together so the smaller protrusion at the end fits together, and place it into one of the three larger holes on the side of the shroud.

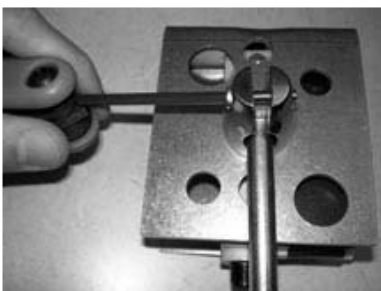

Step 4

Position and align the mounting bracket to the reflector, then tighten the half-clamp set screw to secure the assembly

Figure 4: LG2-x-4 Mounting Instructions

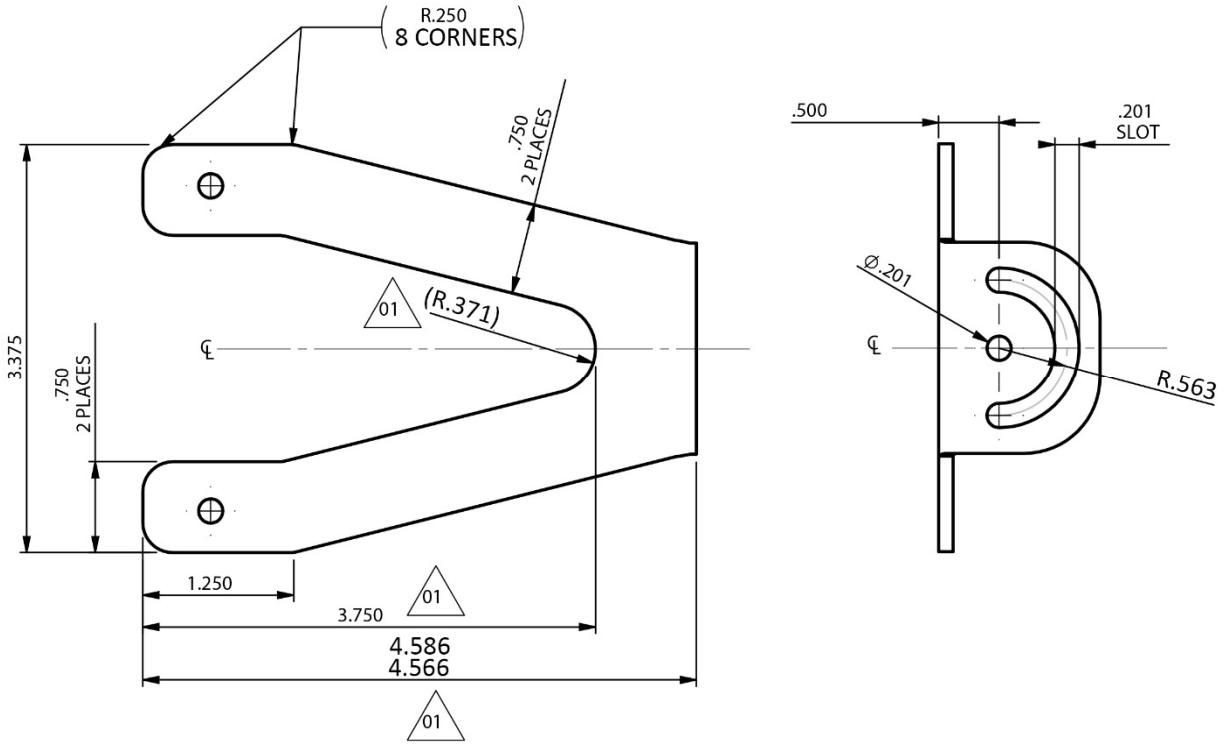

Figure 5: LG2-x-4X Laser Bracket

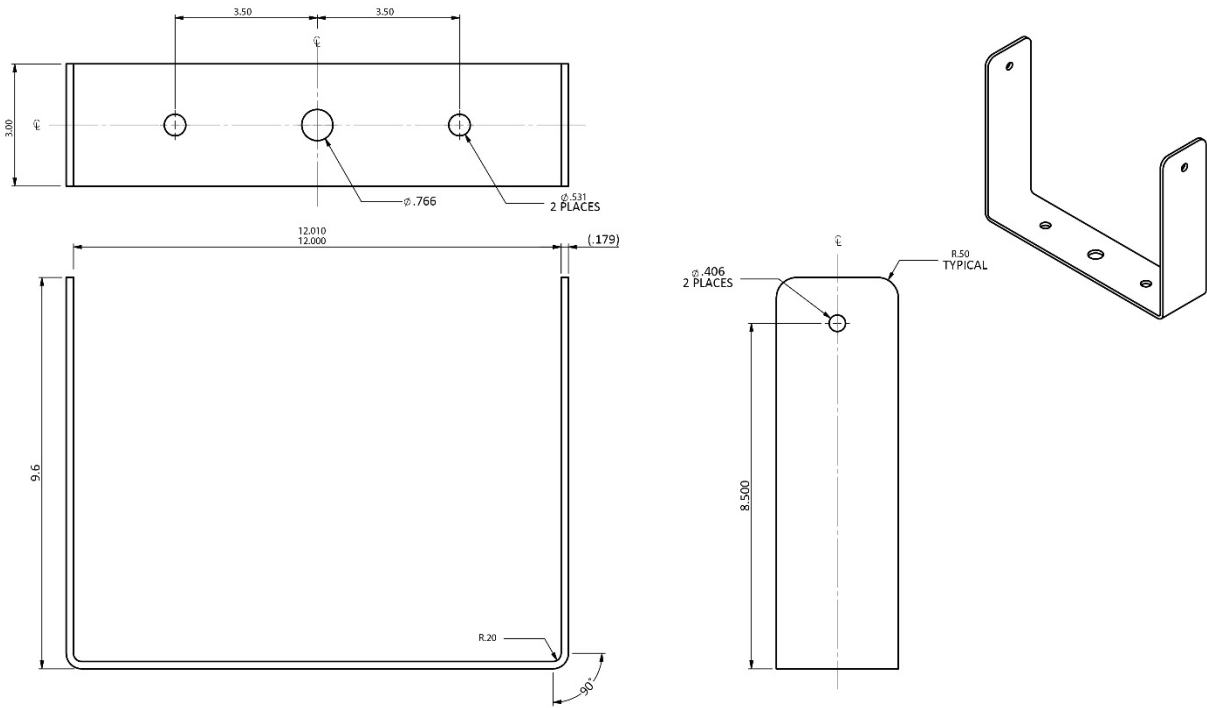

Figure 6: LG2-x-4X Enclosure Bracket

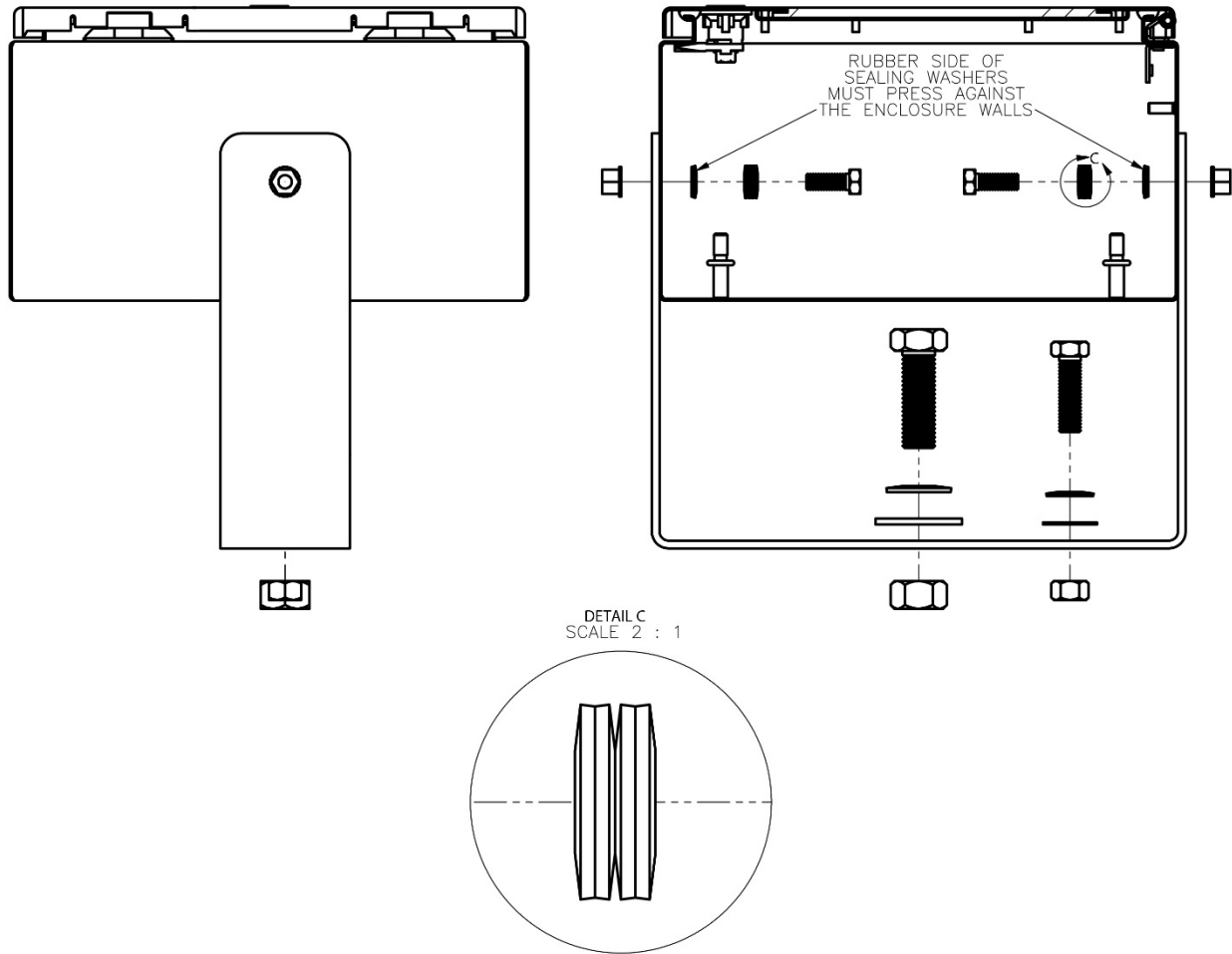

Figure 7: LG2-x-4X Mounting Instructions

Install the laser and the target in the positions found in Figure 8 and Figure 9. Mount the laser securely to a solid surface to minimize vibration so that the crane's load or movement will not affect the laser's alignment. The laser and laser support unit should also be mounted as close to the control panel as possible to minimize long cable runs.

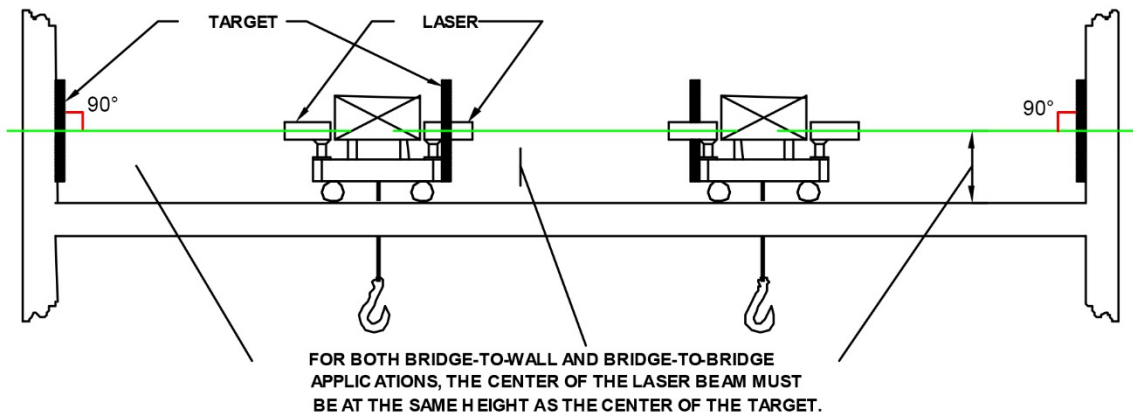
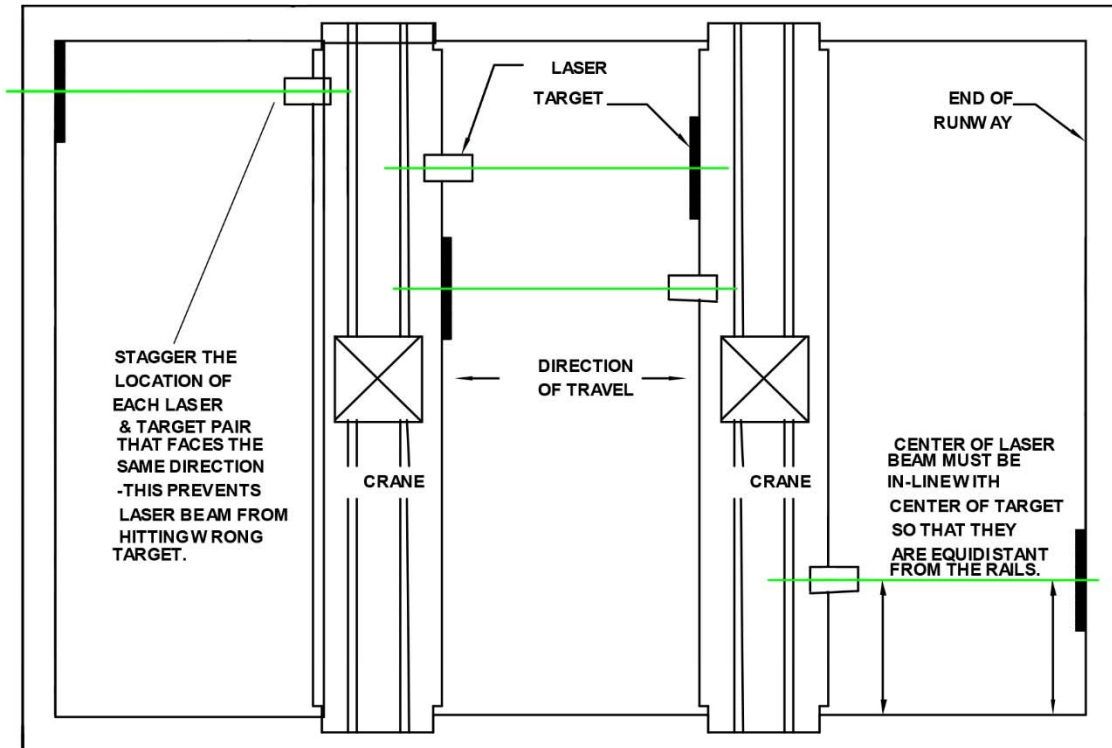

Figure 8: Laser and Target Installation

For best reflectivity/laser signal, mount the reflector in the same orientation as the laser so the laser beam is perpendicular to the reflector. The arrow on the back of the reflector should be the same direction as the laser (refer to Figure 9).

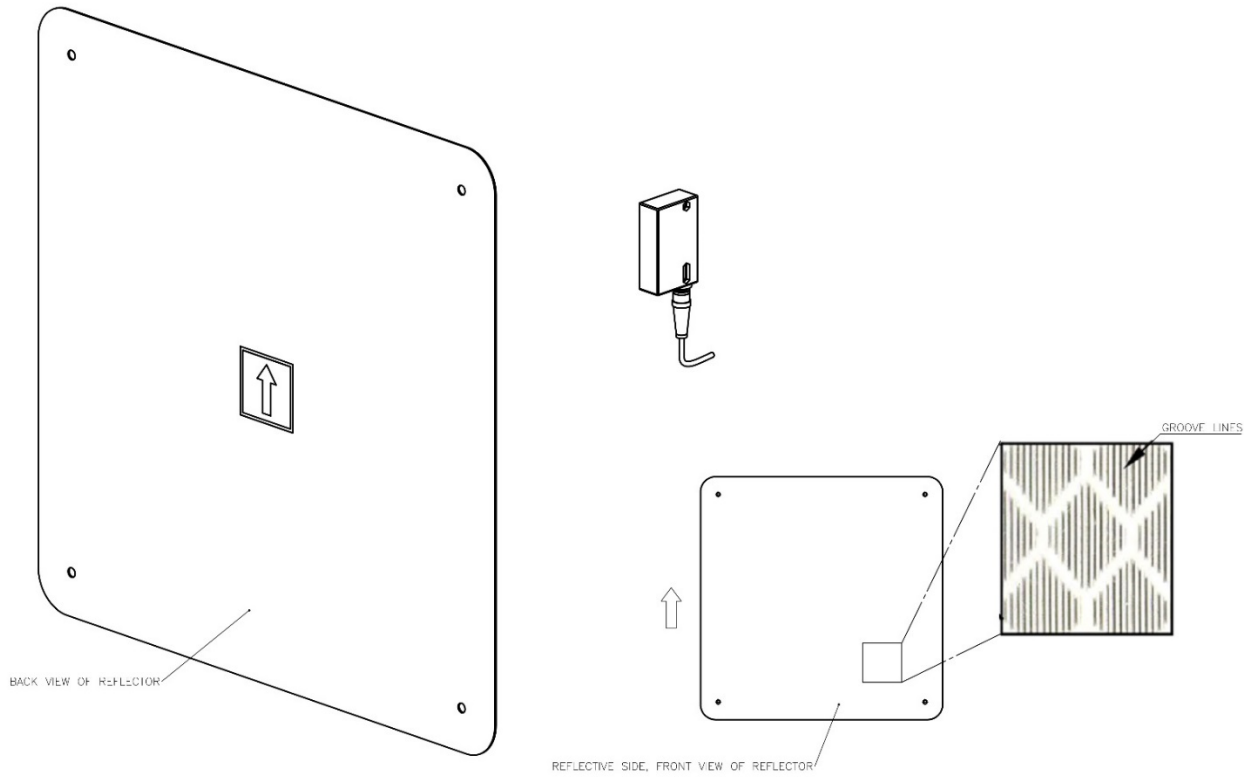
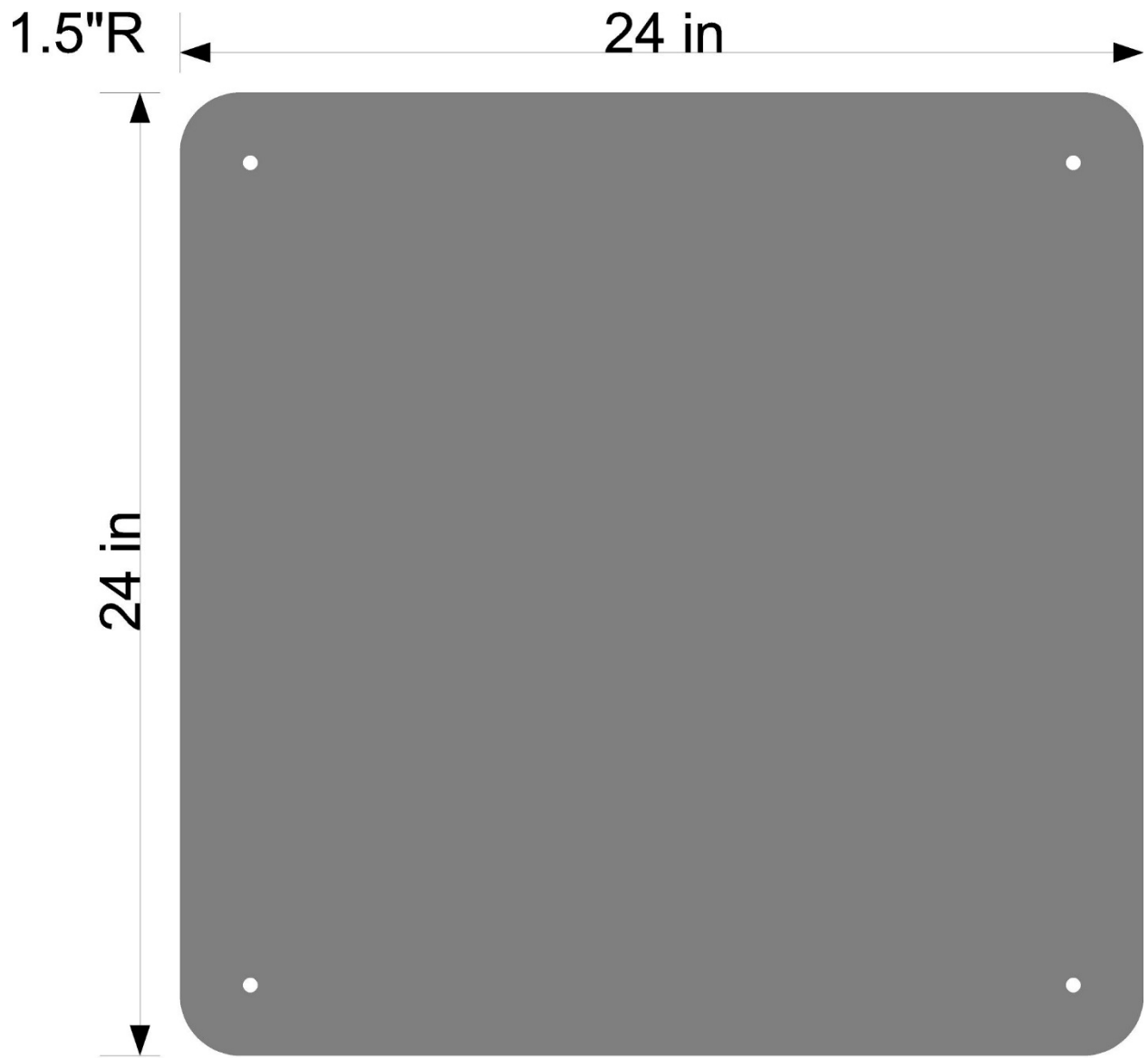

Figure 9: Laser and Target Orientation



24" Square 0.063 - 0.08 gauge, 1.5" Rad
w/ (4) 3/8" holes 1.75" in on corners

Figure 10: Target Dimensions

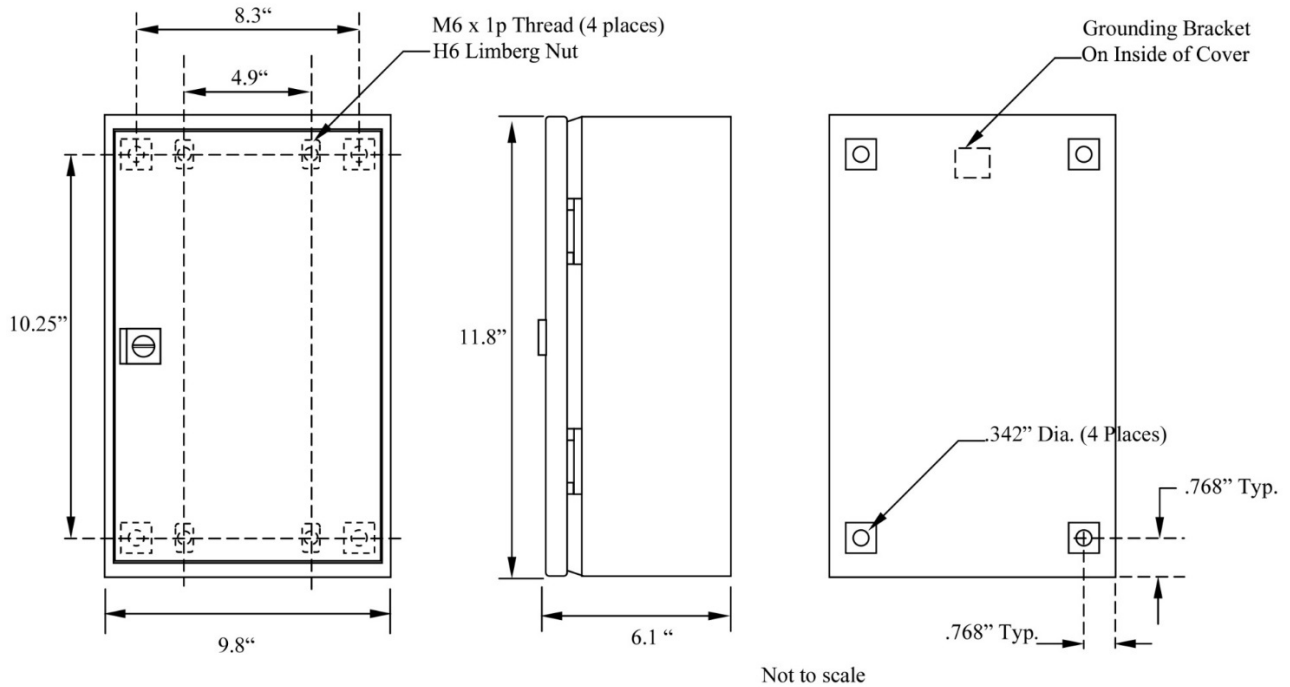
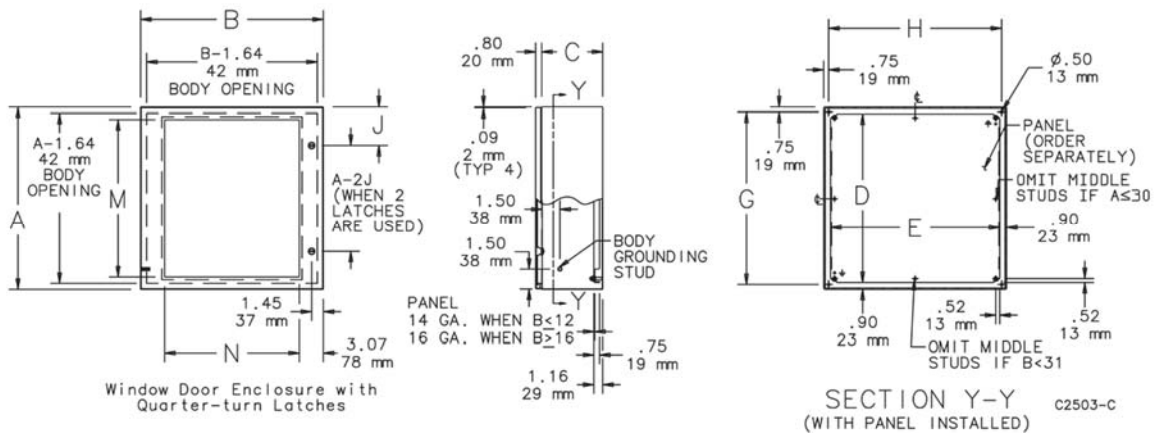

Figure 11: Enclosure Dimensions



- | | |
|------------------------------|------------------------------|
| A – 12.00 in (305 mm) | G – 10.50 in (267 mm) |
| B – 12.00 in (305 mm) | H – 10.50 in (267 mm) |
| C – 6.00 in (152 mm) | M – 8.74 in (222 mm) |
| D – 10.20 in (259 mm) | N – 7.10 in (180 mm) |
| E – 10.20 in (295 mm) | |

Figure 12: Enclosure Dimensions for LG-H-4X and LG-L-4X

3.5. Electrical Installation

The laser unit interface cable and all other wiring should be run in separate 1/2" or 3/4" conduit. Do not run any other cables in the same conduit with the laser head cable.

A suitable disconnect should be provided by the installer.

Run conduit between the laser support unit and the crane's control panel.

Run conduit from the LSU to about 1 ft. from the laser. Putting a slight downward bend in the conduit at the laser transceiver will help keep dirt and water out. Place a protective end piece on the open end of the conduit to protect the laser cable from sharp edges.

Pull the supplied laser cable by the end that does not have a connector on it through the conduit, starting from the opened laser unit end and into the LSU. Leave enough cable on the laser end so that it is twice as long as the distance between the end of the conduit and the laser unit (about 2 ft. to 3 ft.). This will produce a service loop, which will also help keep dirt and water out of the open end of conduit (refer to Figure 13). This cable consists of four wires. See Figure 14 through Figure 16 for wiring information for this cable. Plug the connector into the laser unit. The connector is keyed; do not force.

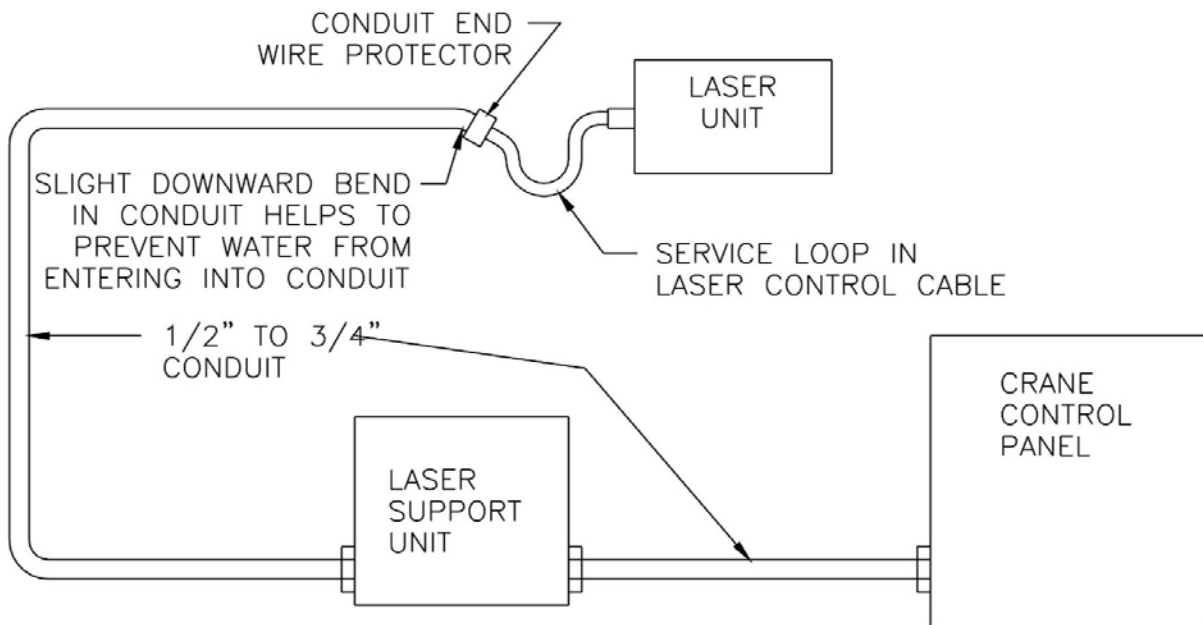

Figure 13: Conduit Installation

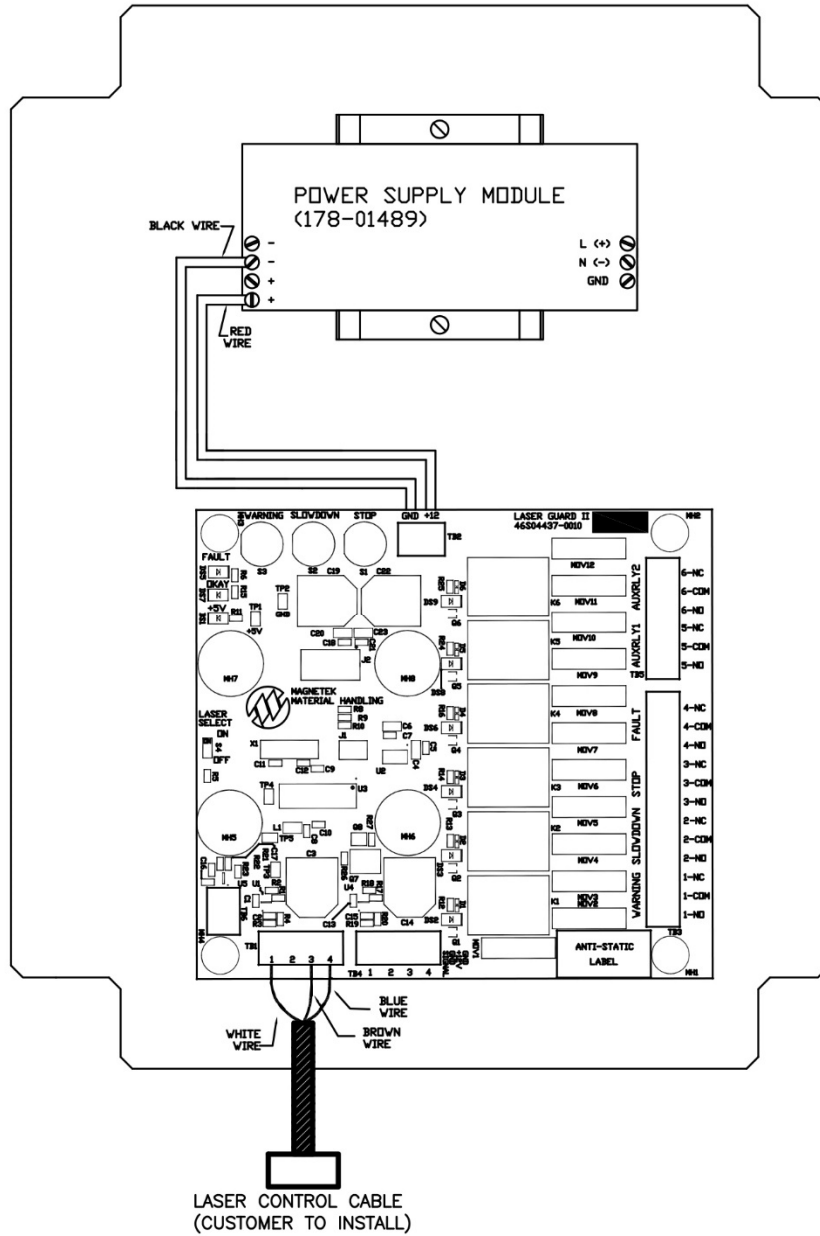

Figure 14: Laser Support Unit Wiring for LG2-H-4

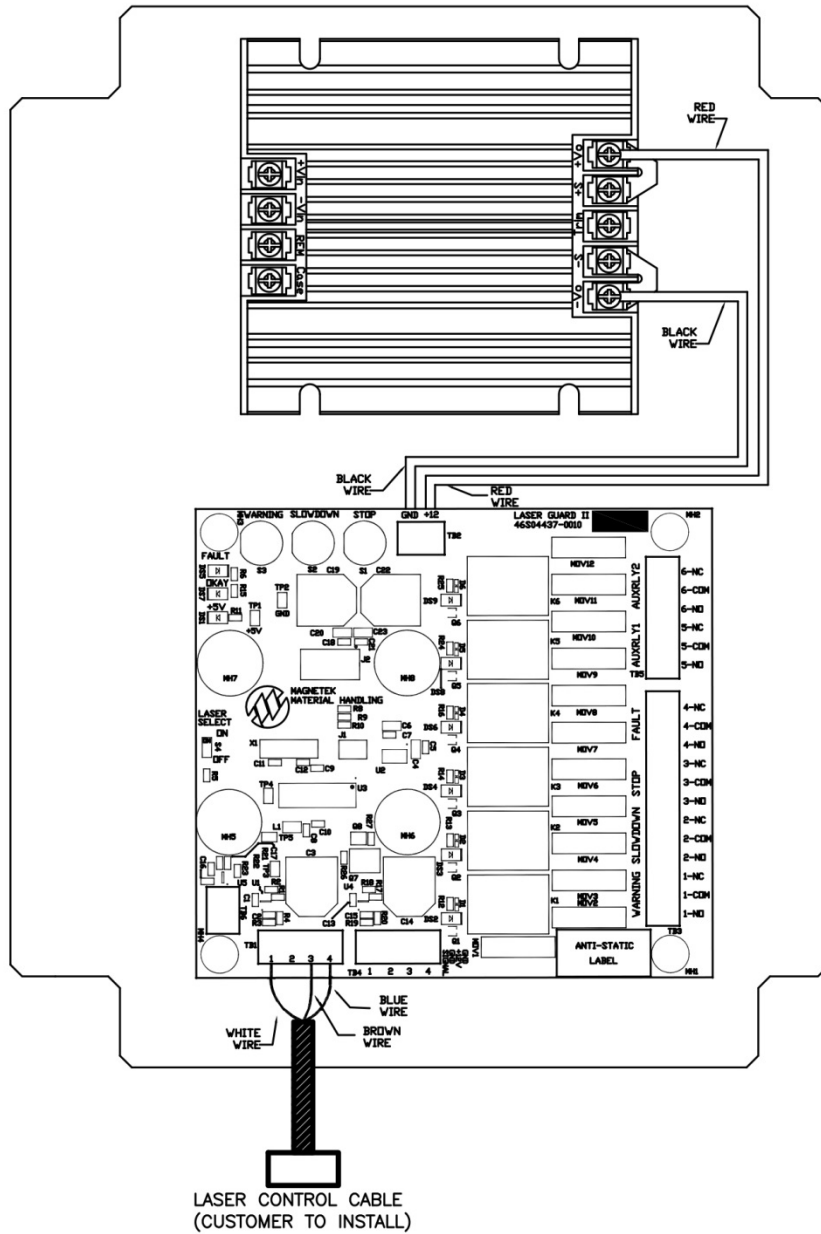
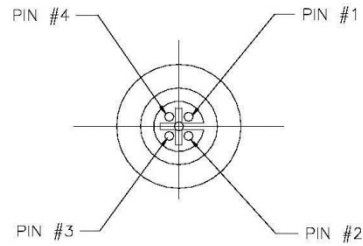

Figure 15: Laser Support Unit Wiring for LG2-L-4



LASER UNIT CONNECTION PIN NUMBER	WIRE COLOR	RANGE DETECTOR J2 WIRE TERMINATION (REFERENCE ONLY)
1	BROWN	TO RANGE DETECTOR #3 12V TO LASER
2	WHITE	TO RANGE DETECTOR #1 4 TO 20 ma INPUT
3	BLUE	TO RANGE DETECTOR #4 12V RETURN FROM LASER
4	BLACK	NOT USED

Figure 16: Laser Connector Wiring Diagram

Wire the outputs of the laser support unit (TB3) to the crane control panel (refer to Figure 14 or Figure 17). The recommended wire size is 16 AWG, but can be between 24 to 12 AWG. Please observe National Electrical Code (NEC) guidelines when wiring electrical devices.

Please note that the "NO" and "NC" markings on the laser support unit control board are the conditions of the output relays when a range point or a fault has been detected. Place snubbers across the contactor coils in the crane's control panel that are to be controlled as necessary.

Run power to the power supply in the LSU (refer to Figure 14 and Figure 15). Make certain that the input power provided matches the input requirements of the power supply used in this system; if it does not, stop here and notify Magnetek Customer Service.

Turn on the power to the laser support unit and note that the green LED on the laser head is on continuously after a few seconds. If that does not occur, turn the power off and recheck all wiring.

For wiring special crane configurations such as magnetic control, timed bypass, or stepped/stepless VFD, see the figures listed below in the back of the manual.

Figure 18: LaserGuard2 Stepped Series 4 VFD Control, Protection in One Direction (Recommended)

Figure 19: LaserGuard2 Crane Control, Protection in One Direction

Figure 20: LaserGuard2 Crane Control with Timed Bypass, Protection in One Direction

Figure 21: LaserGuard Magnetic Crane Control, Protection in Both Directions

Figure 22: LaserGuard2 Stepped VFD Control, Protection in One Direction

Figure 23: Typical LaserGuard2 Interface with Stepless VFD Control

Figure 24: Typical LaserGuard2 Interface with P&H Stepless Control

3.6. Mechanical Alignment

Loosen the bolt on the bottom of the mounting rod and the screw on the clamp so the laser head can be angled up and down, and from left to right with just enough friction so the laser head does not fall over on its own.

Point the laser head in the direction of the target. While watching the target, slowly turn or angle the mount as needed until the laser dot is seen in the middle of the target.

While keeping the laser unit from moving, carefully tighten the bolt and screw.

3.7. Range Detector Settings

The range detector settings are defaulted at approximately 91 ft., 83 ft., and 75 ft. for Warning, Slowdown, and Stop. It may be necessary to bypass the default range detector settings during set-up; this can be done by holding down WARNING and SLOWDOWN at the same time for two seconds. At that time, the Warning, Slowdown, and Stop points will be between 8 in. and 3 ft.

Setting the range detection points will require movement of the crane to the desired distances.

1. Move the crane to the point at which the warning is needed and press the white WARNING button.
2. Move the crane to the slowdown point and press the gray SLOWDOWN button. This distance must be less than that in the previous step.
3. Move the crane to the last point where the brakes are to be applied and press the black STOP button. This distance must be less than that in Step 2.
4. Move the crane away from the target and then back again to verify all range points are triggered at the correct distances.

Remember to consider the deceleration time within the VFD and the hysteresis within the LSU when setting up detection points. For example, if the STOP button is pressed at 10 ft., that contact will turn on at approximately 11 ft. and turn off at approximately 9 ft.

3.8. Fault Check

The Temporary Loss of Signal Fault may be tested by bringing the laser to a distance from the target operating range and then momentarily blocking the laser's view of the target. This should cause a 10 second fault, which will light DS5 on the LSU control board. All of the relays will drop out (the total dropout time is approximately 10 seconds) and DS5 will flash three times before the relay will come back on (refer to Table 1). If this fault does not occur, reduce the distance between the laser and the target and repeat the test.



CAUTION

DO NOT WAIT FOR A FAULT TO OCCUR BEFORE PERFORMING PREVENTIVE MAINTENANCE.
DO NOT CONTINUE TO RELY ON THE LASERGUARD SYSTEM IF A FAULT HAS OCCURRED UNTIL
MAINTENANCE HAS CORRECTED THE PROBLEM.

3.9. Troubleshooting

NOTE: Please refer to Table 1 for the Laser Diagnostic LED Functions referred to in this section.

If the green LED on the laser head flashes at 4Hz, the laser has short circuited. Replace the laser unit. Do not try to service it. Return it to the factory.

If the laser is aligned and the red dot is not visible on the reflector, check for +12V at terminals marked +12V and GND at TB1 on the range detector module. If 12V is not present, check the power supply in the laser support unit. If 12V is present, turn the power off and check the continuity of the cable (refer to Figure 14 through Figure 16). Replace defective sub-assemblies as necessary. If none are found, replace the laser head.

When the laser head is greater than 150 ft. from its target, or an object is blocking the path of the laser for more than 10 seconds, the following conditions should exist on the range detector module:

The three LEDs (DS4, DS3, and DS2) (refer to Figure 17) next to each range detector should be lit, and the red LED (DS6) by the fault detector should be lit. The red FAULT LED (DS5) should be off.

If the red FAULT LED is flashing, check Table 1 to determine the cause.

Table 1: Laser Diagnostic LED Functions

NOTE: See Figure 17 for LED locations.

LED	COLOR	FUNCTION
Laser Head Operating Display	Green	Monitors voltage to the Laser Head Normally ON.
Laser Head Signal	Yellow	Monitors target acquisition. Normally ON when target is acquired. It turns off when the laser is off the target, out of range, or has a dirty lens. Random or rapid flashing of this LED could indicate a weak signal caused by too much of a reflector angle. Make sure the reflector is not bent, and that its orientation is per Figure 9. Groove lines visible on the reflective material should be in the same direction as the laser head.
Control Unit DS2, DS3, and DS4	Purple, Yellow, Orange	Monitors closure of the Warning, Slowdown, and Stop range point relays. Normally ON when unit turned ON and at a distance beyond the range points. The LEDs indicate power to the relay. The relays are normally energized. As the unit moves closer to the target the range points sequentially drop out, thus turning off the LEDs in sequence.
Control Unit DS6	Red	Monitors engagement of the Fault Relay. Normally ON when receiver turned ON. The LED will extinguish when a fault of some type has been detected, thus tripping the relay. Check LEDs on laser head and DS5 for possible fault conditions.
Control Unit DS1	Green	Monitors unregulated 5 VDC. Normally ON. Check wiring to board and AC power to unit.
Control Unit DS5/DS7	Red/Green	Displays fault code. <div style="display: flex; flex-direction: column; gap: 10px;"> <div> <p>Temporary Loss of Signal</p> </div> <div> <p>Laser Undercurrent</p> </div> <div> <p>Set Points Out of Sequence</p> </div> <div> <p>Laser Overcurrent</p> </div> </div>

4. Installation Diagrams

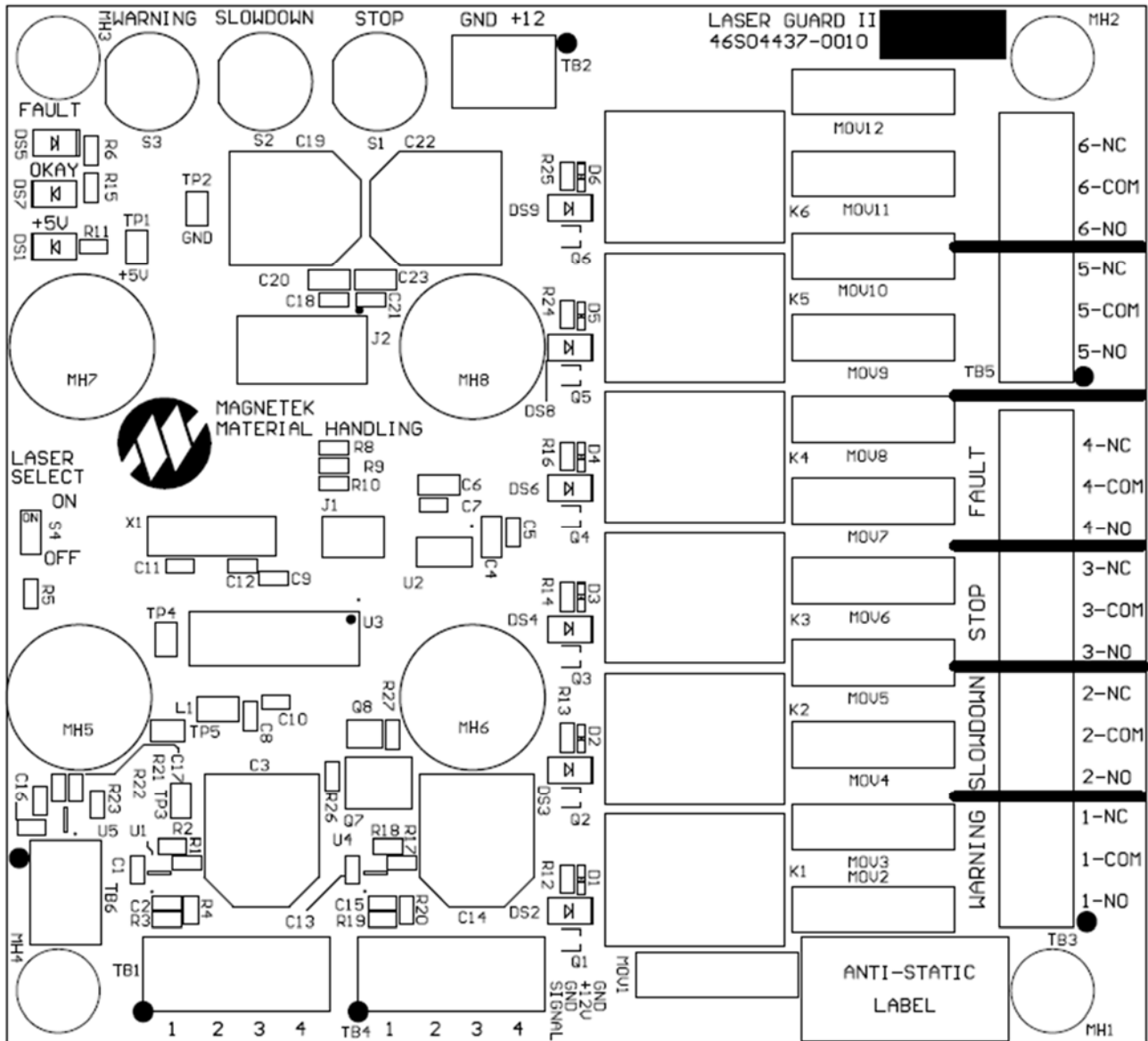

Figure 17: Component Locations

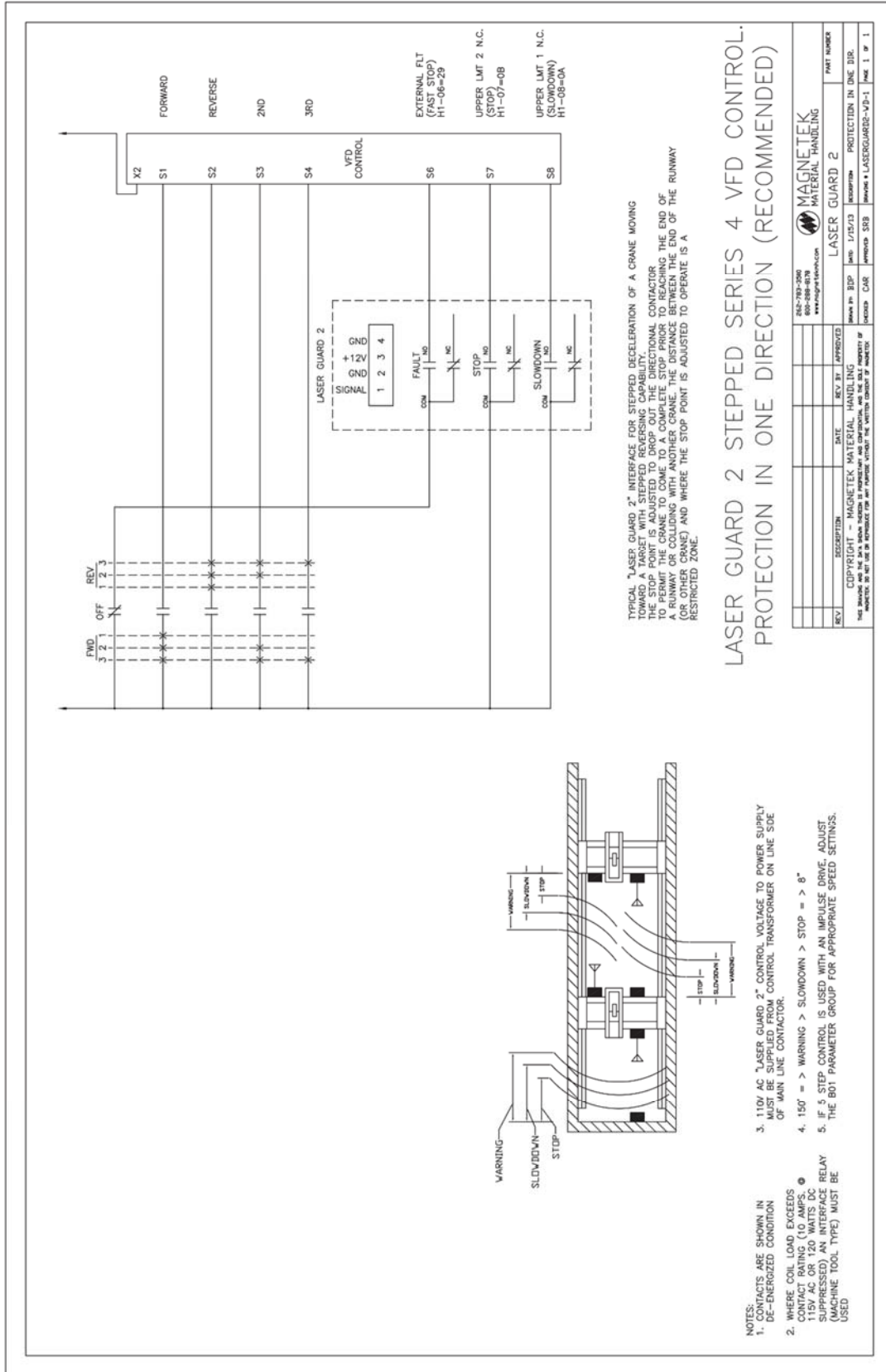

Figure 18: LaserGuard2 Stepped Series 4 VFD Control, Protection in One Direction (Recommended)

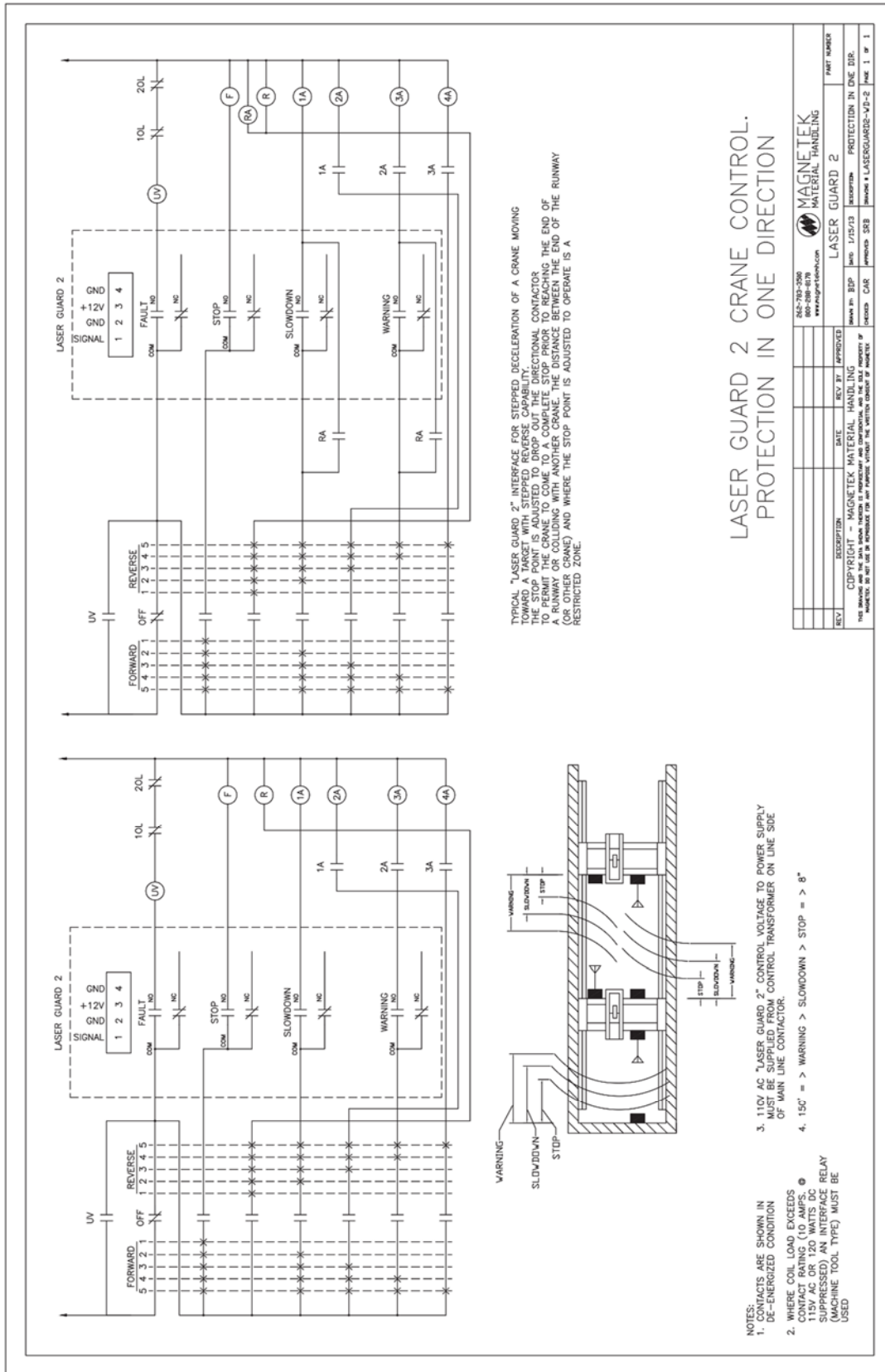

Figure 19: LaserGuard2 Crane Control, Protection in One Direction

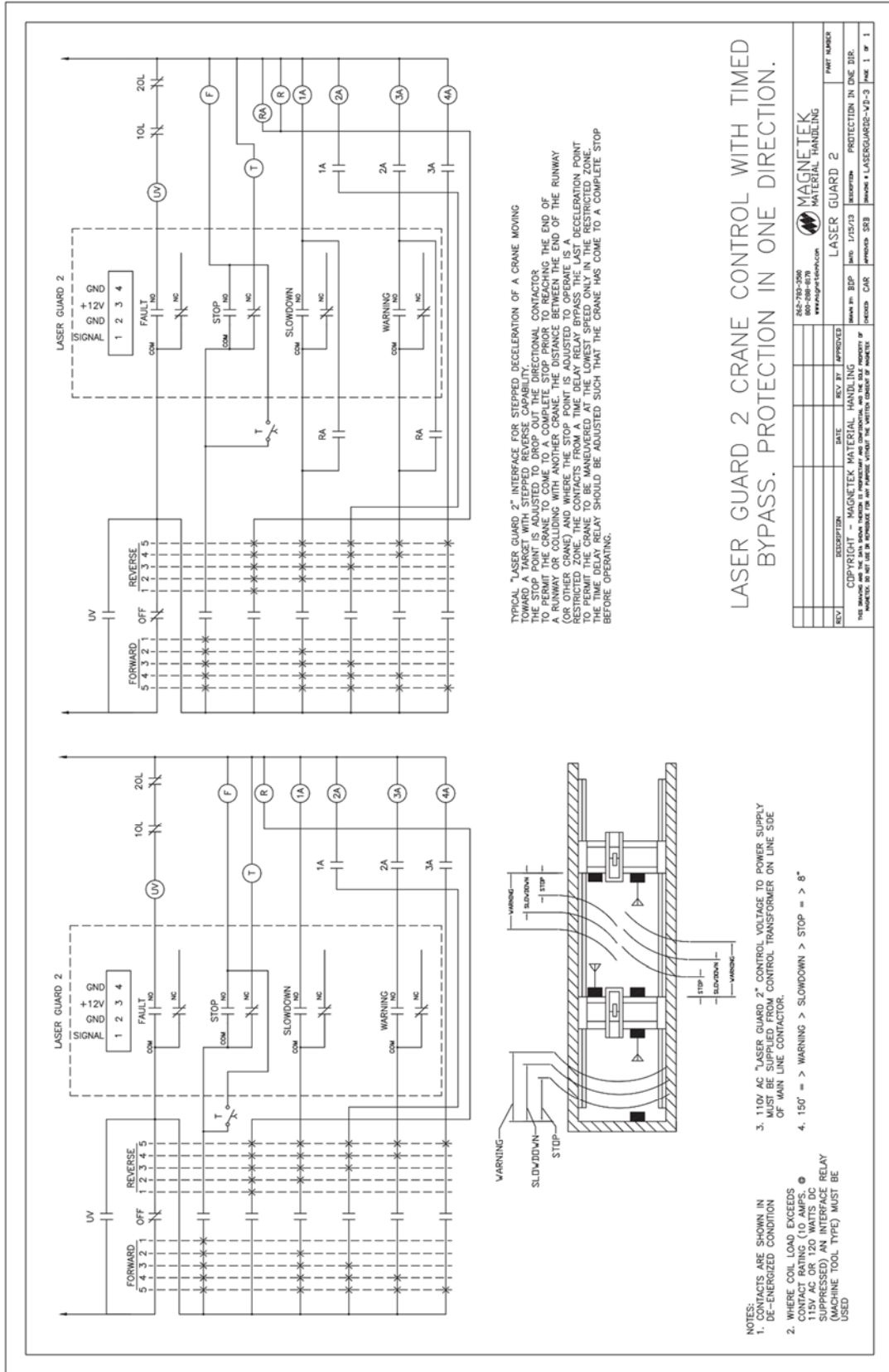

Figure 20: LaserGuard2 Crane Control with Timed Bypass, Protection in One Direction

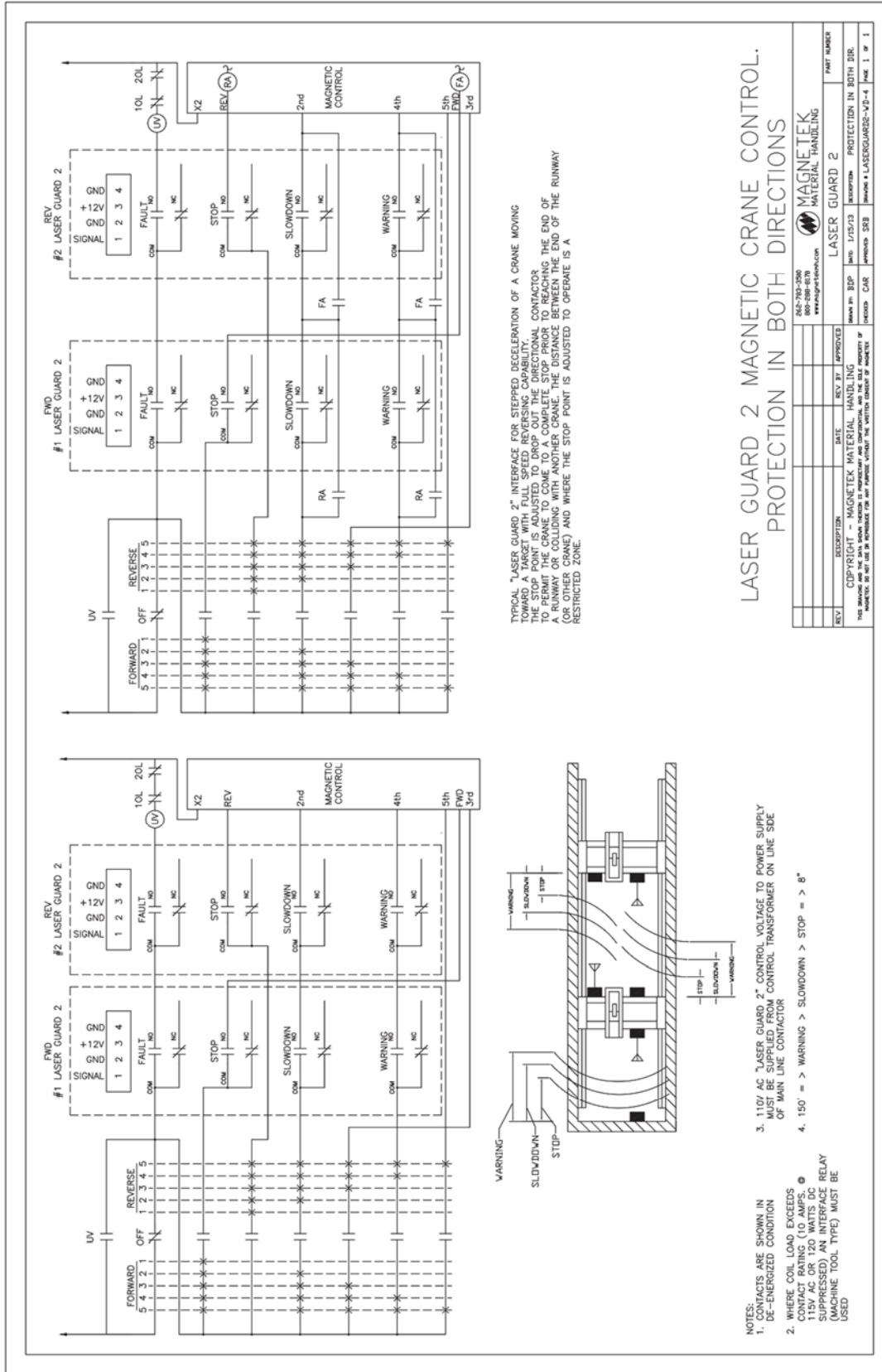

Figure 21: LaserGuard Magnetic Crane Control, Protection in Both Directions

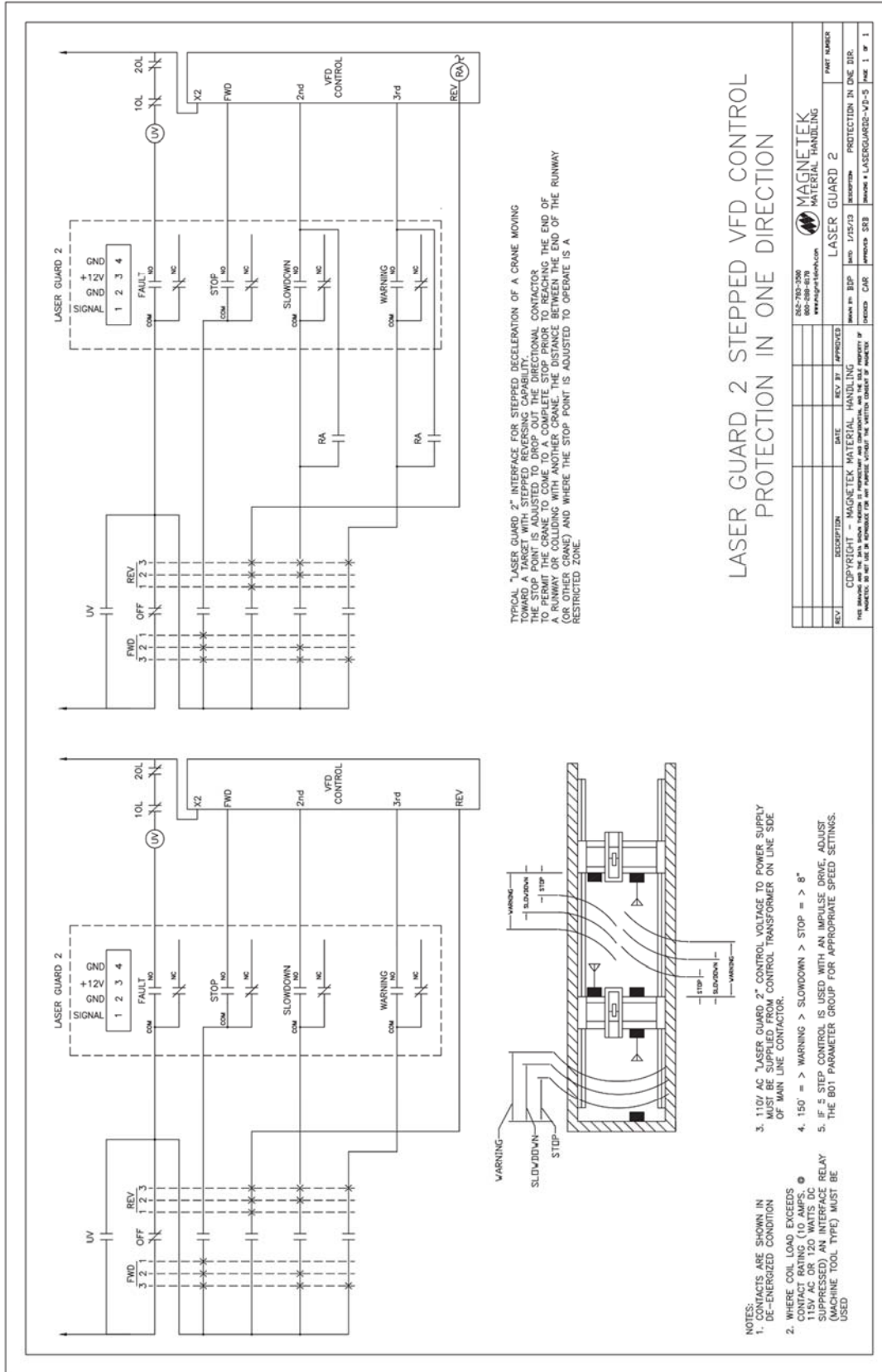

Figure 22: LaserGuard2 Stepped VFD Control, Protection in One Direction

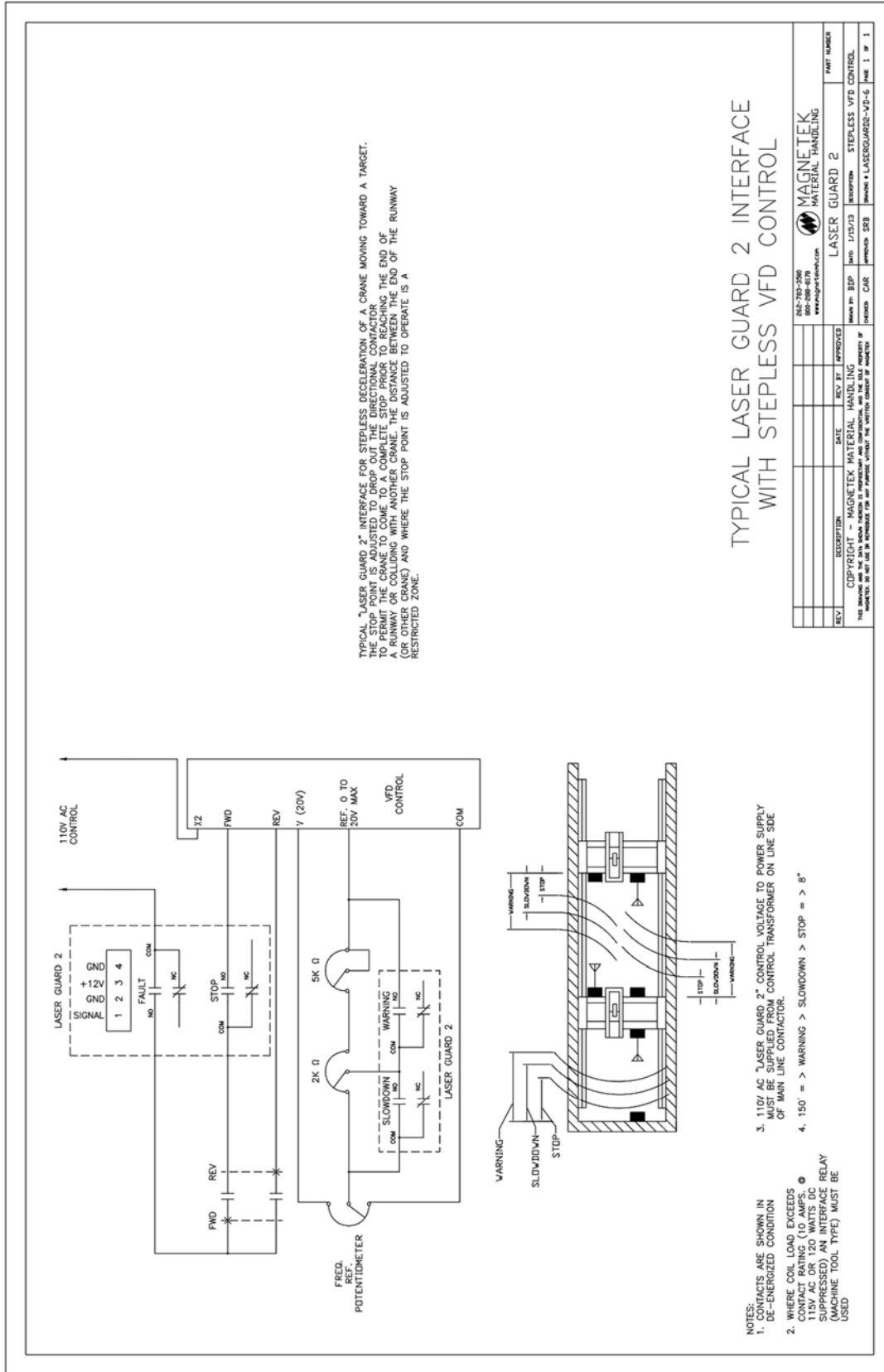

Figure 23: Typical LaserGuard2 Interface with Stepless VFD Control

