



# ReFlx 45

---

## Collision Avoidance System Instruction Manual



**MAGNETEK**  
MATERIAL HANDLING

Part Number: 147-20011 R0  
February 2015

©Copyright 2015 Magnetek Material Handling

# Table of Contents

<b>Service Contact Information</b> .....	<b>3</b>
<b>Preface and Safety</b> .....	<b>4</b>
Product Safety Information.....	4
Product Warranty Information .....	4
DANGER, WARNING, CAUTION, and NOTE Statements.....	5
Crane Safety .....	5
Collision Avoidance Unit.....	5
Operating the Crane with the ReFlx 45.....	5
Cleaning Recommendations (Preventative Measures).....	5
<b>1. General System Information</b> .....	<b>6</b>
1.2 System Description .....	6
1.2.1 Sensor .....	6
1.2.2 Adjustments.....	6
1.2.3 Indicators.....	6
1.3 System Specifications .....	7
<b>2. Mechanical Installation</b> .....	<b>8</b>
<b>3. Electrical Installation</b> .....	<b>13</b>
<b>4. Troubleshooting</b> .....	<b>15</b>
<b>Appendix A</b> .....	<b>16</b>

## Service Contact Information

For questions regarding service or technical information contact:

1-866-MAG-SERV  
(1-866-624-7378)

Magnetek Material Handling  
N49 W13650 Campbell Drive  
Menomonee Falls, WI 53051

**Telephone:** 800-288-8178

**Website:** [www.magnetek.com](http://www.magnetek.com)

**E-mail:** [MHcustomerservice@magnetek.com](mailto:MHcustomerservice@magnetek.com)

**Fax Numbers:**

Main: 800-298-3503

Sales: 262-783-3510

Service: 262-783-3508

Magnetek, Inc. has additional satellite locations for Canada and the United States. For more information, please visit <http://www.magnetek.com>.

©2015 MAGNETEK

# Preface and Safety

©2015 MAGNETEK

All rights reserved. This notice applies to all copyrighted materials included with this product, including, but not limited to, this manual. This manual is intended for the sole use of the persons to whom it was provided, and any unauthorized distribution of the manual or dispersal of its contents is strictly forbidden. This manual may not be reproduced in whole or in part by any means whatsoever without the expressed written permission of Magnetek.

## Product Safety Information

Magnetek, Inc. (Magnetek) offers a broad range of radio remote control products, control products and adjustable frequency drives, industrial braking systems, and power delivery products for material handling applications. This manual has been prepared by Magnetek to provide information and recommendations for the installation, use, operation and service of Magnetek's material handling products and systems (Magnetek Products). Anyone who uses, operates, maintains, services, installs or owns Magnetek Products should know, understand and follow the instructions and safety recommendations in this manual for Magnetek Products.

The recommendations in this manual do not take precedence over any of the following requirements relating to cranes, hoists, lifting devices or other equipment which use or include Magnetek Products:

- Instructions, manuals, and safety warnings of the manufacturers of the equipment where the Magnetek Products are used,
- Plant safety rules and procedures of the employers and the owners of the facilities where the Magnetek Products are being used,
- Regulations issued by the Occupational Health and Safety Administration (OSHA),
- Applicable local, state, provincial, or federal codes, ordinances, standards and requirements, or
- Safety standards and practices for the industries in which Magnetek Products are used.

This manual does not include or address the specific instructions and safety warnings of these manufacturers or any of the other requirements listed above. It is the responsibility of the owners, users and operators of the Magnetek Products to know, understand and follow all of these requirements. It is the responsibility of the employer to make its employees aware of all of the above listed requirements and to make certain that all operators are properly trained.

No one should use Magnetek Products prior to becoming familiar with and being trained in these requirements and the instructions and safety recommendations for this manual.

## Product Warranty Information

Magnetek, hereafter referred to as Company, assumes no responsibility for improper programming of a device (such as a drive or radio) by untrained personnel. A device should only be programmed by a trained technician who has read and understands the contents of the relevant manual(s). Improper programming of a device can lead to unexpected, undesirable, or unsafe operation or performance of the device. This may result in damage to equipment or personal injury. Company shall not be liable for economic loss, property damage, or other consequential damages or physical injury sustained by the purchaser or by any third party as a result of such programming. Company neither assumes nor authorizes any other person to assume for Company any other liability in connection with the sale or use of this product.

For information on Magnetek's product warranties by product type, please visit [www.magnetek.com](http://www.magnetek.com).

## DANGER, WARNING, CAUTION, and NOTE Statements

Read and understand this manual before installing, operating, or servicing this product. Install the product according to this manual and local codes.

The following conventions indicate safety messages in this manual. Failure to heed these messages could cause fatal injury or damage products and related equipment and systems.



### DANGER

DANGER indicates an imminently hazardous situation which, if not avoided, will result in death or serious injury. This signal word is to be limited to the most extreme situations.



### WARNING

WARNING indicates a potentially hazardous situation which, if not avoided, could result in death or serious injury.



### CAUTION

CAUTION indicates a potentially hazardous situation which, if not avoided, could result in minor or moderate injury. It may also be used to alert against unsafe practices.

*NOTE: A NOTE statement is used to notify people of installation, operation, programming, or maintenance information that is important, but not hazard-related.*

## Crane Safety

### Collision Avoidance Unit

The sensor and reflector should never be disabled for any crane motion. If the unit is for any reason disengaged or turned off the crane operating personnel must be notified immediately and proper alternate operation precautions taken.

### Operating the Crane with the ReFlx 45

The crane collision avoidance unit and limit switches, if any, should be checked at the beginning of each shift or when a new operator takes control of the crane. When checking the collision avoidance unit and limit switches the hoist should be centered over an area free of personnel and equipment.

The collision avoidance unit and limit switches should never be used as a regular, repetitive stopping device. They are intended to be protective devices.

### Cleaning Recommendations (Preventative Measures)



### CAUTION

DO NOT WAIT FOR AN ACCIDENT TO OCCUR BEFORE PERFORMING PREVENTATIVE MAINTENANCE. WIPE THE SENSOR AND REFLECTOR DOWN AT REGULAR INTERVALS TO PREVENT DUST BUILD-UP THAT MAY INHIBIT THE SENSOR SIGNAL.

# 1. General System Information

The ReFlx 45 Collision Avoidance System is intended for use with overhead crane bridges and trolleys and monorails to prevent collisions or to limit the approach of adjacent structures. The system has a polarized retroreflective sensor that can detect the distance between two objects, such as the bridges of two overhead cranes or the bridge and a wall. When the sensor detects that the object is closer than the trip point distance, the form C relay will change state. This is a single sensor system that would most commonly be used for a single stop command.

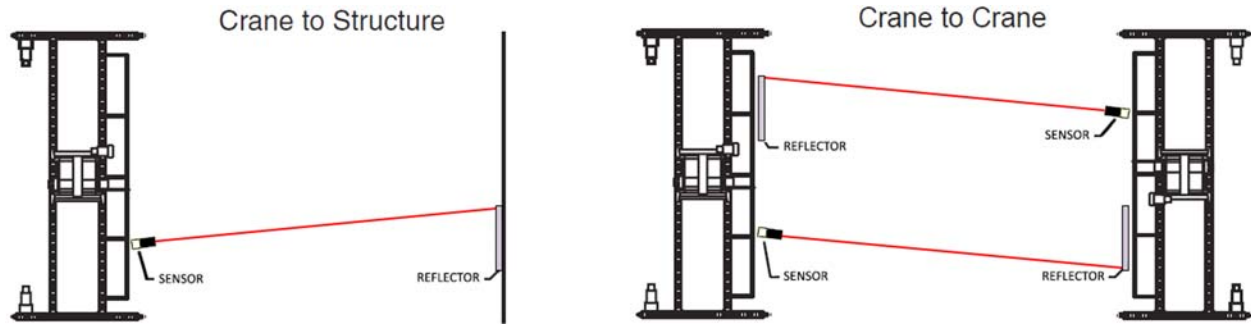

Figure 1: ReFlx 45 Collision Avoidance System

Table 1: ReFlx 45 Models

Model Number	Description
REFLX45-AD	Sensor, mounting bracket, and adhesive-backed reflector
REFLX45-DIN	Sensor, mounting bracket, and rail-mounted reflector
REFLX45-ADH	Sensor, hinged mounting bracket, and adhesive-backed reflector
REFLX45-DINH	Sensor, hinged mounting bracket, and rail-mounted reflector

## 1.2 System Description

### 1.2.1 Sensor

The ReFlx 45 is a polarized sensor with cross talk protection; because of this feature, there is no minimum distance necessary between the sensors. The sensing beam on the ReFlx 45 is large, which is an advantage with skewed runways.

### 1.2.2 Adjustments

The sensor features four DIP switches to customize the use of any delays or invert the output switching, and two dials control the delay time and the distance sensitivity. The delay is adjustable up to 10 seconds while the trip point is adjustable up to 45 ft. The DIP switches are located in the back of the sensor under the cover, and the dials are located on the top of the sensor.

*NOTE: Magnetek recommends leaving the switches and dials at their default positions.*

### 1.2.3 Indicators

Two green LEDs are located on the top of the sensor: one in the front, and the other in the back. They indicate that the sensor is powered on. Two yellow LEDs next to the power indicators specify the object is within the sensing range. The yellow LEDs will flash under the following conditions: when the object is

approaching the sensing range/trip point, the sensor or reflector is dirty, or the sensor is slightly skewed. Beyond the trip point, the yellow LEDs will turn off.

### 1.3 System Specifications

Specification	Specification Values and Information
Detection Range	approx. 3~45 ft.
Operating Voltage	12~240V AC/DC
Power Consumption	≤ 3.5 VA
Signal Output	Relay, Form C rated at 250 V AC/DC, 2 A max
Switching Power Output	DC: max. 50 W; AC: max. 500 VA
Response Time	≤ 20 ms
Operating Mode Selection	DIP switch
Light Source	LED
Ambient Light Limit	80000 Lux
Ambient Temperature	-40°~140°F (-40°~60°C)
Storage Temperature	-40°~167°F (-40°~75°C)
Housing	Polycarbonate IP67
Terminal Block	Spring Loaded 16-20 AWG
Strain Relief	0.275~0.315 in. cable outside diameter

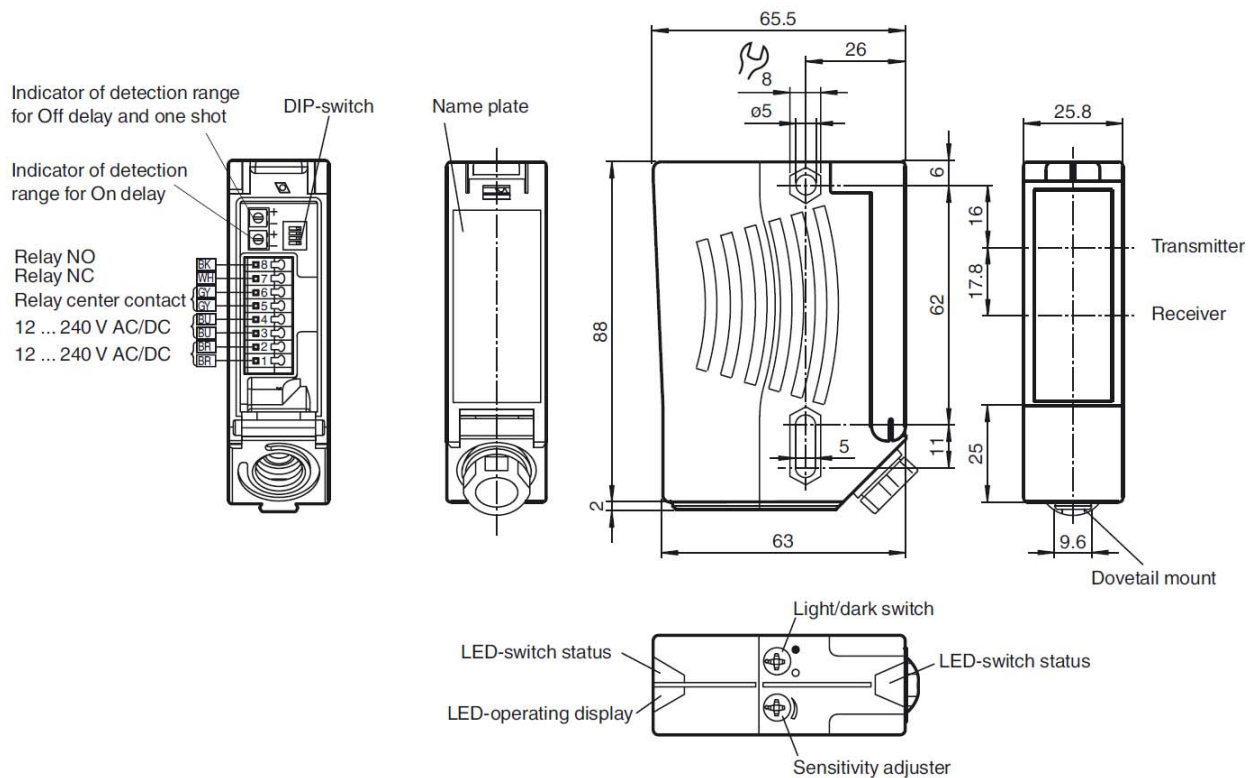

**Figure 2: Sensor Layout and Dimensions (in mm)**

## 2. Mechanical Installation

When mounting the sensor, no obstructions should be present between the sensor and the reflective target. The sensor should be mounted so that the center of the sensor is lined up vertically with the center of the reflective target. The mounting bracket provided allows for vertical adjustment by loosening the screws through the curved slot. The sensor angle can be adjusted horizontally by loosening the screws that secure the bracket. For fine adjustment of the sensor, it helps to view the target from a location within 1 ft. of the sensor, as it is difficult to see the red light reflected on the target if viewed from a distance greater than 1 ft. in any direction.

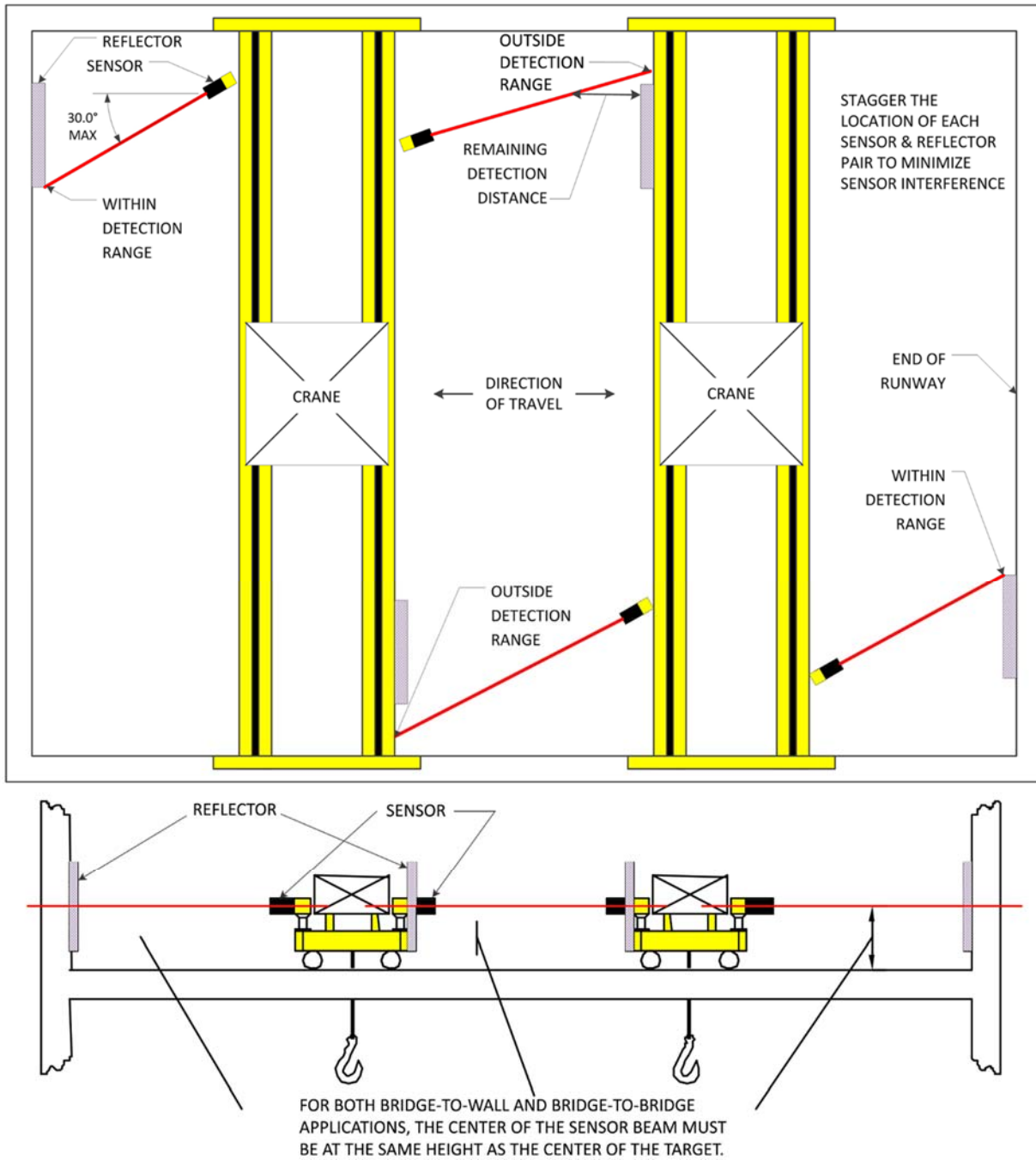

**Figure 3: Sensor and Target Installation**



The default position that the “sense” dial is set to is the maximum distance. It is recommended to set the trip point distance slightly greater than required, as time is needed to stop a moving crane; refer to Table 2 and Table 3 to help set up this distance. Once the required distance is reached, angle the sensor outside of the 30° mark. Gradually angle the sensor into the perpendicular position of the crane until the relay trips and the yellow indicator is illuminated. When finished, tightly close the cover to prevent dust from getting inside the sensor.

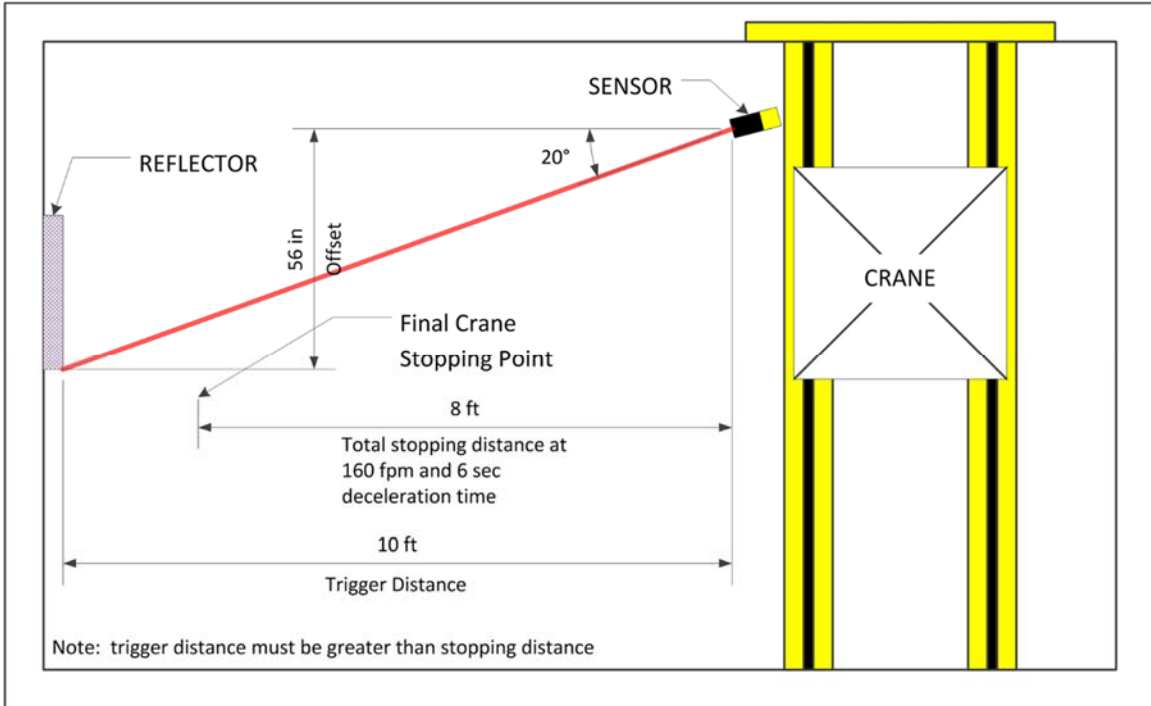

**Figure 4: Calculating the Offset Distance**

**Table 2: Offset Values (based on Trigger Distance and Angle)**

Angle (°)	5	10	15	20	25	30
Trigger Dist. (ft)	Offset (in)					
3	3 1/4	6 1/4	9 3/4	13 1/4	16 3/4	20 3/4
4	4 1/4	8 1/2	13	17 1/2	22 1/2	27 3/4
5	5 1/4	10 3/4	16 1/4	21 3/4	28	34 3/4
6	6 1/4	12 3/4	19 1/4	26 1/4	33 3/4	41 3/4
7	7 1/4	14 3/4	22 1/2	30 3/4	39 1/4	48 1/2
8	8 1/2	17	25 3/4	35	44 3/4	55 1/2
9	9 1/2	19	29	39 1/4	50 1/2	62 1/2
10	10 1/2	21 1/4	32 1/4	43 3/4	56	69 1/4
11	11 1/2	23 1/4	35 1/2	48	51 3/4	76 1/4
12	12 3/4	25 1/2	38 3/4	52 1/2	67 1/4	83 1/4
13	13 3/4	27 1/2	41 3/4	56 3/4	72 3/4	90 1/4
14	14 3/4	29 3/4	45	61 1/4	78 1/4	97
15	15 3/4	31 3/4	48 1/4	65 1/2	84	104
16	16 3/4	34	51 1/2	70	89 1/2	111
17	17 3/4	36	54 3/4	71 1/4	95 1/4	117 3/4
18	19	38 1/4	58	78 3/4	100 3/4	124 3/4
19	20	40 1/4	61 1/4	83	106 1/4	131 3/4
20	21	42 1/4	64 1/4	87 1/2	112	138 3/4
21	22	44 1/2	67 1/2	91 3/4	117 1/2	145 1/2
22	23 1/4	46 3/4	70 3/4	96 1/4	123 1/4	152 1/2
23	24 1/4	48 3/4	74	100 1/2	128 3/4	159 1/4
24	25 1/4	50 3/4	77 1/4	104 3/4	134 1/4	166 1/4
25	26 1/4	53	80 1/2	109 1/4	140	173 1/2
26	27 1/4	55	83 3/4	113 3/4	145 1/2	180 1/4
27	28 1/4	57 1/4	86 3/4	118	151 1/4	187 1/4
28	29 1/2	59 1/4	90	122 1/4	156 3/4	194
29	30 1/2	61 1/2	93 1/4	126 3/4	162 1/4	201
30	31 1/2	63 1/2	96 1/2	131	168	207 3/4
31	32 1/2	65 3/4	99 3/4	135 1/2	173 1/2	214 3/4
32	33 3/4	67 3/4	103	139 3/4	179 1/4	221 3/4
33	34 3/4	69 3/4	106 1/4	144 1/4	184 3/4	228 3/4
34	35 3/4	72	109 1/4	148 1/2	190 1/4	235 3/4
35	36 3/4	74 1/4	112 1/2	153	195 3/4	242 1/2
36	37 3/4	76 1/4	115 3/4	157 1/4	201 1/2	249 1/2
37	38 3/4	78 1/4	119	161 3/4	207	256 1/4
38	40	80 1/2	112 1/4	166	212 3/4	263 1/4
39	41	82 1/2	125 1/2	170 1/4	218 1/4	270 1/4
40	42	84 3/4	128 3/4	174 3/4	223 3/4	277 1/4
41	43	86 3/4	131 3/4	179 1/4	229 1/2	284 1/4
42	44 1/4	89	135	183 1/2	235	291
43	45 1/4	91	138 1/4	187 3/4	240 3/4	298
44	46 1/4	93 1/4	141 1/2	192 1/4	246 1/4	304 3/4
45	47 1/4	95 1/4	144 3/4	196 1/2	251 3/4	311 3/4

**Table 3: Stopping Distance (based on Deceleration Time and Crane Speed)**

Decel Time* (s)	3	4	5	6	8	10
Crane Speed (fpm)	Stopping Distance at Max Speed (ft)					
100	2.5	3.33	4.17	5	6.67	8.33
110	2.75	3.67	4.58	5.5	7.33	9.17
120	3	4	5	6	8	10
130	3.25	4.33	5.42	6.5	8.67	10.83
140	3.5	4.67	5.83	7	9.33	11.67
150	3.75	5	6.25	7.5	10	12.5
160	4	5.33	6.67	8	10.67	13.33
170	4.25	5.67	7.08	8.5	11.33	14.17
180	4.5	6	7.5	9	12	15
190	4.75	6.33	7.92	9.5	12.67	15.83
200	5	6.67	8.33	10	13.33	16.67
210	5.25	7	8.75	10.5	14	17.5
220	5.5	7.33	9.17	11	14.67	18.33
230	5.75	7.67	9.58	11.5	15.33	19.17
240	6	8	10	12	16	20
250	6.25	8.33	10.42	12.5	16.67	20.83
260	6.5	8.67	10.83	13	17.33	21.67
270	6.75	9	11.25	13.5	18	22.5
280	7	9.33	11.67	14	18.67	23.33
290	7.25	9.67	12.08	14.5	19.33	24.17
300	7.5	10	12.5	15	20	25
310	7.75	10.33	12.92	15.5	20.67	25.83
320	8	10.67	13.33	16	21.33	26.67
330	8.25	11	13.75	16.5	22	27.5
340	8.5	11.33	14.17	17	22.67	28.33
350	8.75	11.67	14.58	17.5	23.33	29.17
360	9	12	15	18	24	30
370	9.25	12.33	15.42	18.5	24.67	30.83
380	9.5	12.67	15.83	19	25.33	31.67
390	9.75	13	16.25	19.5	26	32.5
400	10	13.33	16.67	20	26.67	33.33

\*Include S-curve times in the total deceleration time

To determine the Decel Time in Table 3, parameters from the IMPULSE® drive can be used in the following equation:

$$\text{Total Deceleration Time} = B05-02 + \frac{D09-03 + D09-04}{2}$$

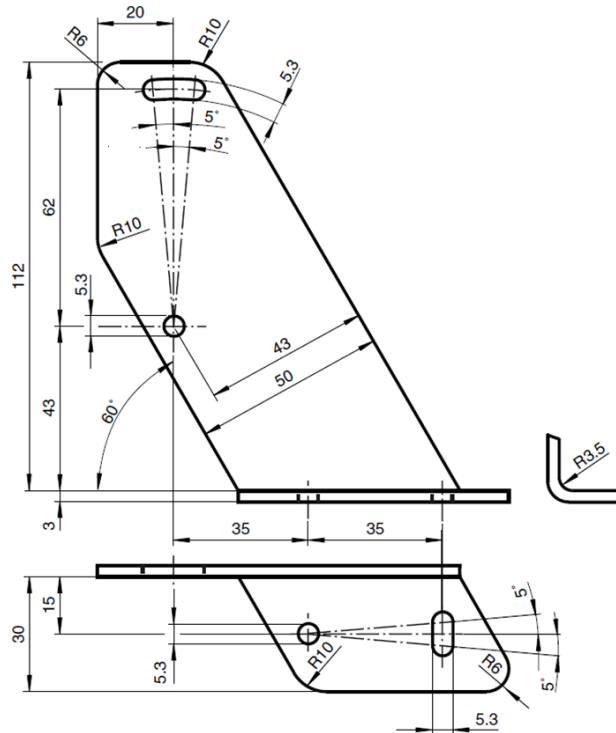

Figure 5: Mounting Bracket Dimensions (in mm)

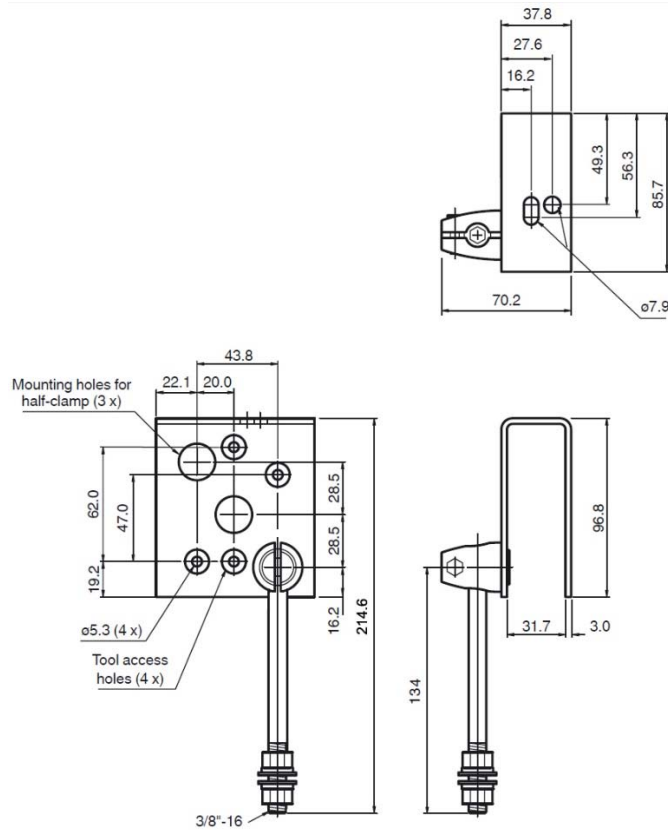

Figure 6: Hinged Mounting Bracket Dimensions (in mm)

### 3. Electrical Installation

While the sensor offers multiple options for operation, Magnetek recommends the following settings for overhead crane collision avoidance applications to ensure optimum safety.



**Figure 7: Recommended DIP Switch Settings for Overhead Crane Collision Avoidance Applications**

With the switches in the above position, the NO contact will be closed when the sensor is powered and crane is at a safe distance from the target. Alternately, the NO contact will be open when the sensor reaches an unsafe distance, i.e. the trip point or when the sensor loses power. With these settings, the position of the delay dial is irrelevant.

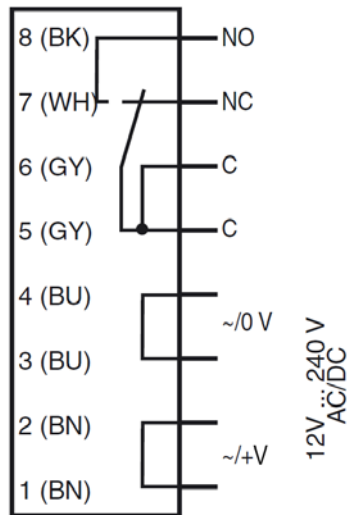

**Figure 8: Electrical Connections**

Figure 9 shows how to connect the sensor to an IMPULSE®•G+/VG+ Series 4 drive utilizing a sensor for both of the directions the crane would move down the bridge. This example stops motion in the direction of travel when the sensors cross the detection threshold.

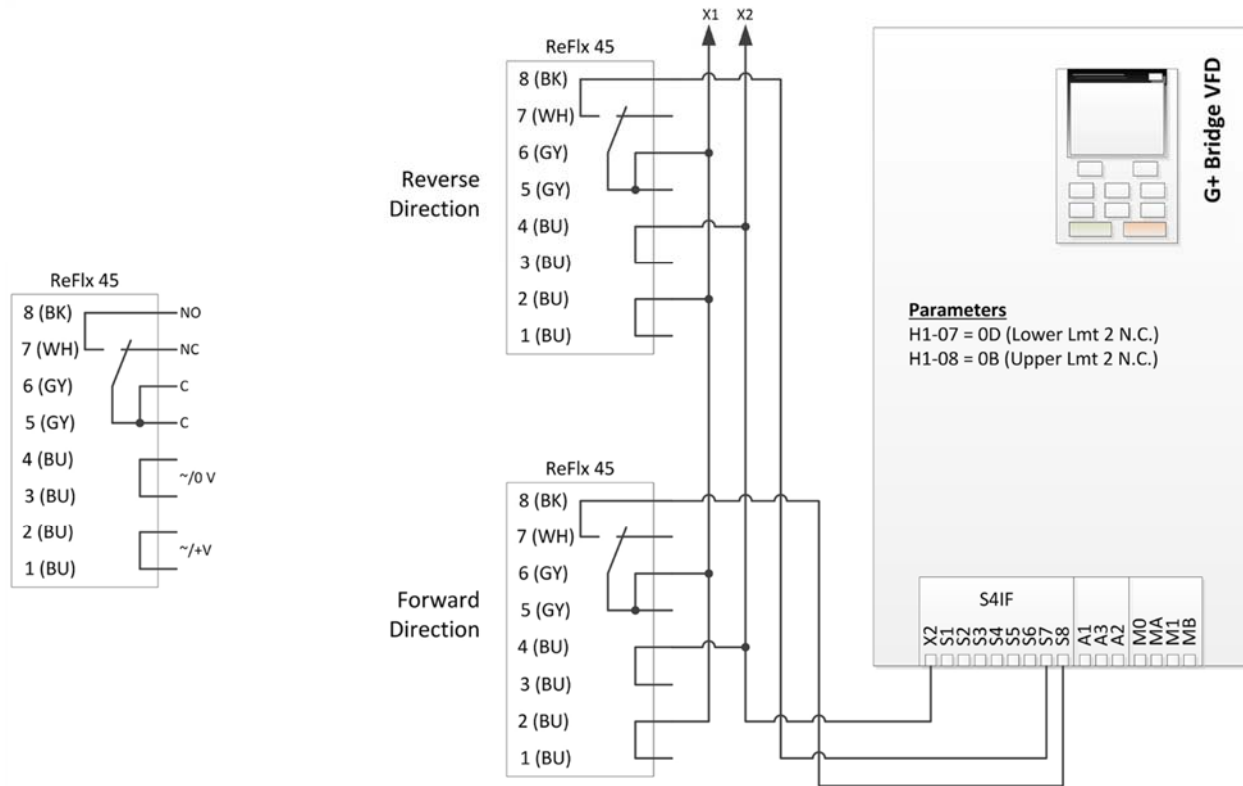

Figure 9: Connection Example for ReFlx 45 and an IMPULSE® G+/VG+ Series 4 Drive

## 4. Troubleshooting



### CAUTION

DO NOT WAIT FOR AN ACCIDENT TO OCCUR BEFORE PERFORMING PREVENTATIVE MAINTENANCE. WIPE THE SENSOR AND REFLECTOR DOWN AT REGULAR INTERVALS TO PREVENT DUST BUILD-UP THAT MAY INHIBIT THE SENSOR SIGNAL.

LED Status	Information and Corrective Action(s)
Green LED is OFF	The green LED indicates power to the sensor. Check for power to the brown wire, and ensure the blue wire is properly grounded. If there is power to the sensor but the green LED is still OFF, contact your Magnetek representative for a replacement.
Yellow LED is OFF	The yellow LED is OFF when the sensor or crane is at a safe distance from the reflector. If there is power to the sensor and the distance between the sensor and reflector is closer than the set trip point, this LED should be ON. If it is OFF at that distance, check for misalignment and objects in front of the sensor.
Yellow LED is ON or FLASHING	If the yellow LED is ON or FLASHING, the crane has reached an unsafe distance (trip point), and should stop before collision. Move the crane away from the object in order to turn the LED OFF.

The DIP switch settings are used to control the delay function available with the ReFlx 45. Figure 10 **Error! Reference source not found.** below shows how this can be used.

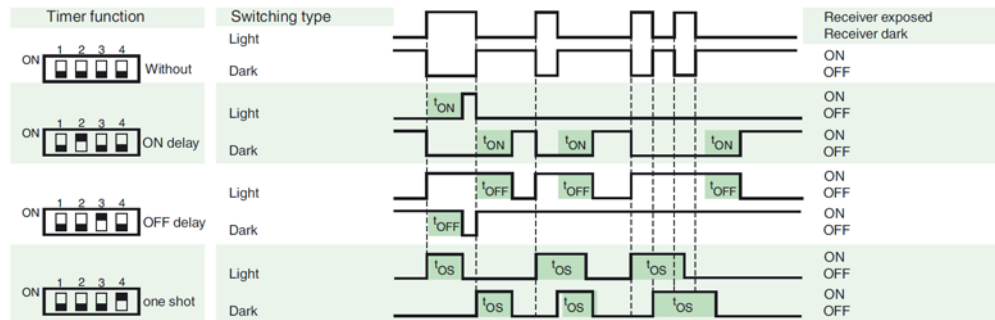

Time  $t_{ON}$ ,  $t_{OFF}$  and  $t_{OS}$  are adjustable from 0.1 to 10 seconds.  
The Light-/Dark-Switch (Left, outer switch) is shown in the "Dark ON" position.

**Figure 10: Timer Functions**

# Appendix A

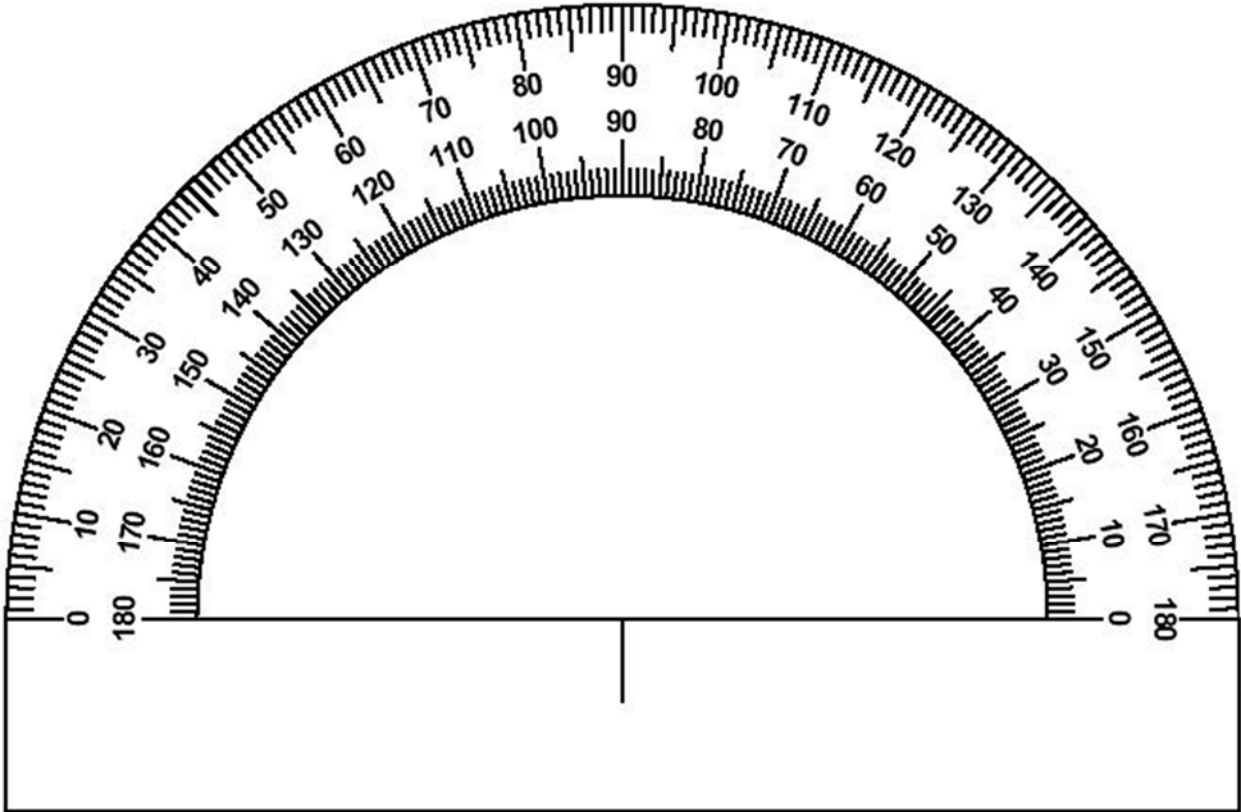

Figure 11: Half-circle Protractor, Marked in Degrees (180°)