

Flex PRO / Flex M Pre-Engineered

Radio Control System



MAGNETEK
E N R A N G E

Part Number: 191-00195-1200

April 2012

© 2012 Magnetek Material Handling

TABLE OF CONTENTS

1. INTRODUCTION.....	6
2. RADIO CONTROLLED SAFETY	7
2.1. WARNINGS AND CAUTIONS.....	7
2.2. CRITICAL INSTALLATION CONSIDERATIONS	8
2.3. GENERAL.....	8
2.4. PERSONS AUTHORIZED TO OPERATE RADIO CONTROLLED CRANES.....	8
2.5. SAFETY INFORMATION AND RECOMMENDED TRAINING FOR RADIO CONTROLLED EQUIPMENT OPERATORS	9
2.6. TRANSMITTER UNIT	10
2.7. PRE-OPERATION TEST	10
2.8. BATTERIES	11
2.9. BATTERY HANDLING	11
2.10. BATTERY CHARGING	11
2.11. BATTERY DISPOSAL.....	11
2.12. SPECIFIC SYSTEM WARNINGS.....	12
2.13. FLEX M RECEIVER INSTALLATION.....	12
2.14. PRE-INSTALLATION	12
3. GENERAL TRANSMITTER INFORMATION	13
3.1. EXTERNAL ILLUSTRATION (PRO 12 CONFIGURATION).....	13
3.2. INTERNAL ILLUSTRATION (PRO 12 CONFIGURATION).....	14
3.3. TYPES OF BUTTONS	15
3.4. ADJUSTABLE SPEED CONTROL	15
4. DIP SWITCH SETTINGS.....	16
4.1. SYSTEM CHANNEL SETTINGS	16
4.2. INACTIVITY TIME OUT TIMER	17
4.3. A/B/BOTH SELECT	17
5. SYSTEM CHANNEL TABLE	18
6. OPERATING PROCEDURE.....	19
6.1. GENERAL OPERATING PROCEDURE.....	19
6.2. CHANGING TRANSMITTER BATTERIES	20
7.0 RECEIVER MECHANICAL DRAWINGS.....	21
7.1. MECHANICAL LAYOUTS.....	21
7.2. RECEIVER INSTALLATION	23
7.3. REMOVAL.....	24
8. NORMAL OPERATION	25
8.1. POWER SUPPLY MODULE	25
8.2. RF/CPU MODULE	25
8.3. RELAY MODULE(S)	25
8.4. ANALOG I/O MODULE(S)	25
9. FLEX MODULE TYPES.....	27
9.1. FLEX RF/CPU MODULE	27
9.2. FLEX M POWER SUPPLY MODULE.....	28
9.3. FLEX M RELAY MODULE	29
9.4. FLEX M ANALOG I/O MODULE	30

10. RECEIVER CHANNEL CONFIGURATION SETTINGS (BANK 2 ON RF/CPU MODULE)	32
10.1. CHANNEL DIP SWITCH SETTINGS FOR 433MHZ PART 15, VERSION 2 RF/CPU MODULE (25-02-074-816E)	33
10.2. FLEX M 24 AND 32 RELAY PRE-ENGINEERED WIRING	34
10.3. FCC STATEMENTS	36
11. TROUBLESHOOTING.....	37
11.1. TRANSMITTER STATUS LIGHT INDICATORS & WARNINGS.....	37
11.2. TRANSMITTER PUSH BUTTON ERROR TABLE	38
11.3. TROUBLESHOOTING TABLE	39
11.4. ASSEMBLY AND REPLACEMENT PARTS	41
12. NOTES.....	42

PRODUCT MANUAL SAFETY INFORMATION

Magnetek, Inc. (Magnetek) offers a broad range of radio remote control products, control products and adjustable frequency drives, and industrial braking systems for material handling applications. This manual has been prepared by Magnetek to provide information and recommendations for the installation, use, operation and service of Magnetek's material handling products and systems (Magnetek Products). Anyone who uses, operates, maintains, services, installs or owns Magnetek Products should know, understand and follow the instructions and safety recommendations in this manual for Magnetek Products.

The recommendations in this manual do not take precedence over any of the following requirements relating to cranes, hoists lifting devices or other material handling equipment which use or include Magnetek Products:

- Instructions, manuals, and safety warnings of the manufacturers of the equipment where the radio system is used,
- Plant safety rules and procedures of the employers and the owners of facilities where the Magnetek Products are being used,
- Regulations issued by the Occupational Health and Safety Administration (OSHA),
- Applicable local, state or federal codes, ordinances, standards and requirements, or
- Safety standards and practices for the industries in which Magnetek Products are used.

This manual does not include or address the specific instructions and safety warnings of these manufacturers or any of the other requirements listed above. It is the responsibility of the owners, users and operators of the Magnetek Products to know, understand and follow all of these requirements. It is the responsibility of the employer to make its employees aware of all of the above listed requirements and to make certain that all operators are properly trained. **No one should use Magnetek Products prior to becoming familiar with and being trained in these requirements and the instructions and safety recommendations in this manual.**

WARRANTY INFORMATION

For information on Magnetek's product warranties by product type, please visit www.magnetekmh.com.

Your New Flex PRO/Flex M Radio Control System

Thank you for your purchase of Magnetek's Enrange® brand Flex PRO/Flex M Radio Remote Equipment Control. Magnetek has set a whole new standard in radio-remote performance, dependability, and value with this line of modular receivers.

If your product ever needs modification or service, please contact one of our representatives at the following locations:

U.S. Service Information

For questions regarding service or technical information contact:

1.866.MAG.SERV

1.866.624.7378

World Headquarters:

Magnetek, Inc.
N49 W13650 Campbell Drive
Menomonee Falls, WI 53051
Phone: 1.800.288.8178
Fax: 1.800.298.3503

Magnetek, Inc. has additional satellite locations for Canada and the United States. For more information, please visit <http://www.magnetekmh.com>.

©2012 MAGNETEK

All rights reserved. This notice applies to all copyrighted materials included with this product, including, but not limited to, this manual and software embodied within the product. This manual is intended for the sole use of the person(s) to whom it was provided, and any unauthorized distribution of the manual or dispersal of its contents is strictly forbidden. This manual may not be reproduced in whole or in part by any means whatsoever without the expressed written permission of MAGNETEK.

1. INTRODUCTION

The Flex radio remote control systems are designed for control of industrial equipment and machinery such as overhead traveling cranes, jib cranes, gantry cranes, tower cranes, electric hoists, winches, monorails, conveyor belts, mining equipment and other material handling equipment where wireless control is preferred.

Each Flex system consists of a transmitter handset and standard-equipped accessories such as a transmitter waist belt, spare transmitter power key, clear vinyl pouch, "AA" alkaline batteries, compass direction decal sheet and user's manual.

List of notable features include:

- **32 user-programmable channels** – Advanced synthesized RF controls with 32 built-in channels; there are no more fixed channel and fragile quartz crystals to break.
- **Over one million unique ID codes (20bit)** – Each and every Flex system has its own unique ID code; no repeats.
- **Advanced controls** – The Flex system utilizes advanced microprocessor controls with 16-bit CRC which provides ultra-fast, safe, precise, and error-free encoding and decoding.
- **Unique I-CHIP design** – The I-CHIP functions in a way that is very similar to SIM cards used on mobile phones, with the ability to transfer system information and settings from one transmitter to another without the hassle of resetting the spares.
- **Reliable push buttons** – The in-house designed push buttons are rated for more than one million press cycles.
- **Low power consumption** – Requires only two "AA" Alkaline batteries for more than 100 hours of operating time between replacements.
- **Ultra-durable nylon and fiberglass composite enclosures** – Highly resistant to breakage and deformation even in the most abusive environments.
- **Full compliance** – All systems are fully compliant with the FCC Part-15 Rules and Industry Canada Specifications (IC).
- **System Versatility** – The Flex PRO/Flex M Radio Control Systems are able to control up to 4 motions (or 3 motions with A/B Select) with the Flex 8 PRO transmitter or up to 6 motions (or 5 motions with A/B Select) with the Flex 12 PRO transmitter.

2. RADIO CONTROLLED SAFETY

2.1. WARNINGS AND CAUTIONS

Throughout this document WARNING and CAUTION statements have been deliberately placed to highlight items critical to the protection of personnel and equipment.

WARNING – A warning highlights an essential operating or maintenance procedure, practice, etc. which, if not strictly observed, could result in injury or death of personnel, or long term physical hazards. Warnings are highlighted as shown below:



CAUTION – A caution highlights an essential operating or maintenance procedure, practice, etc. which, if not strictly observed, could result in damage to or destruction of equipment, or loss of functional effectiveness. Cautions are highlighted as shown below:



WARNINGS and CAUTIONS SHOULD NEVER BE DISREGARDED.

The safety rules in this section are not intended to replace any rules or regulations of any applicable local, state, or federal governing organizations. Always follow your local lockout and tagout procedure when maintaining any radio equipment. The following information is intended to be used in conjunction with other rules or regulations already in existence. It is important to read all of the safety information contained in this section before installing or operating the Radio Control System.

2.2. CRITICAL INSTALLATION CONSIDERATIONS



WARNING

PRIOR TO INSTALLATION AND OPERATION OF THIS EQUIPMENT, READ AND DEVELOP AN UNDERSTANDING OF THE CONTENTS OF THIS MANUAL AND THE OPERATION MANUAL OF THE EQUIPMENT OR DEVICE TO WHICH THIS EQUIPMENT WILL BE INTERFACED. FAILURE TO FOLLOW THIS WARNING COULD RESULT IN SERIOUS INJURY OR DEATH AND DAMAGE TO EQUIPMENT.

ALL EQUIPMENT MUST HAVE A MAINLINE CONTACTOR INSTALLED AND ALL TRACKED CRANES, HOISTS, LIFTING DEVICES, AND SIMILAR EQUIPMENT MUST HAVE A BRAKE INSTALLED. FAILURE TO FOLLOW THIS WARNING COULD RESULT IN SERIOUS INJURY OR DEATH AND DAMAGE TO EQUIPMENT.

AN AUDIBLE AND/OR VISUAL WARNING MEANS MUST BE PROVIDED ON ALL REMOTE CONTROLLED EQUIPMENT AS REQUIRED BY CODE, REGULATION, OR INDUSTRY STANDARD. THESE AUDIBLE AND/OR VISUAL WARNING DEVICES MUST MEET ALL GOVERNMENTAL REQUIREMENTS. FAILURE TO FOLLOW THIS WARNING COULD RESULT IN SERIOUS INJURY OR DEATH AND DAMAGE TO EQUIPMENT.

FOLLOW YOUR LOCAL LOCKOUT TAGOUT PROCEDURE BEFORE MAINTAINING ANY REMOTE CONTROLLED EQUIPMENT. ALWAYS REMOVE ALL ELECTRICAL POWER FROM THE CRANE, HOIST, LIFTING DEVICE, OR SIMILAR EQUIPMENT BEFORE ATTEMPTING ANY INSTALLATION PROCEDURES. DE-ENERGIZE AND TAGOUT ALL SOURCES OF ELECTRICAL POWER BEFORE TOUCH-TESTING ANY EQUIPMENT. FAILURE TO FOLLOW THIS WARNING COULD RESULT IN SERIOUS INJURY OR DEATH AND DAMAGE TO EQUIPMENT.

THE DIRECT OUTPUTS OF THIS PRODUCT ARE NOT DESIGNED TO INTERFACE DIRECTLY TO TWO STATE SAFETY CRITICAL MAINTAINED FUNCTIONS, I.E. MAGNETS, VACUUM LIFTS, PUMPS, EMERGENCY EQUIPMENT, ETC. A MECHANICALLY LOCKING INTERMEDIATE RELAY SYSTEM WITH SEPARATE POWER CONSIDERATIONS MUST BE PROVIDED. FAILURE TO FOLLOW THIS WARNING COULD RESULT IN SERIOUS INJURY OR DEATH AND DAMAGE TO EQUIPMENT.

2.3. GENERAL

Radio controlled material handling equipment operates in several directions. Cranes, hoists, lifting devices, and other material handling equipment can be large, and operate at high speeds. Quite frequently, the equipment is operated in areas where people are working in close proximity to the material handling equipment. **The operator must exercise extreme caution at all times.** Workers must constantly be alert to avoid accidents. The following recommendations have been included to indicate how careful and thoughtful actions may prevent injuries, damage to equipment, or even save a life.

2.4. PERSONS AUTHORIZED TO OPERATE RADIO CONTROLLED CRANES

Only properly trained persons designated by management should be permitted to operate radio controlled equipment.

Radio controlled cranes, hoists, lifting devices and other material handling equipment should not be operated by any person who cannot read or understand signs, notices and operating instructions that pertain to the equipment.

Radio controlled equipment should not be operated by any person with insufficient eyesight or hearing or by any person who may be suffering from a disorder or illness, is taking any medication that may cause loss of equipment control, or is under the influence of alcohol or drugs.

2.5. SAFETY INFORMATION AND RECOMMENDED TRAINING FOR RADIO CONTROLLED EQUIPMENT OPERATORS

Anyone being trained to operate radio controlled equipment should possess as a minimum the following knowledge and skills before using the radio controlled equipment.

The operator should:

- have knowledge of hazards pertaining to equipment operation
- have knowledge of safety rules for radio controlled equipment
- have the ability to judge distance of moving objects
- know how to properly test prior to operation
- be trained in the safe operation of the radio transmitter as it pertains to the crane, hoist, lifting device or other material handling equipment being operated
- have knowledge of the use of equipment warning lights and alarms
- have knowledge of the proper storage space for a radio control transmitter when not in use
- be trained in transferring a radio control transmitter to another person
- be trained how and when to report unsafe or unusual operating conditions
- test the transmitter emergency stop and all warning devices prior to operation; testing should be done on each shift, without a load
- be thoroughly trained and knowledgeable in proper and safe operation of the crane, hoist, lifting device, or other material handling equipment that utilizes the radio control
- know how to keep the operator and other people clear of lifted loads and to avoid “pinch” points
- continuously watch and monitor status of lifted loads
- know and follow cable and hook inspection procedures
- know and follow the local lockout and tagout procedures when servicing radio controlled equipment
- know and follow all applicable operating and maintenance manuals, safety procedures, regulatory requirements, and industry standards and codes

The operator shall not:

- lift or move more than the rated load
- operate the material handling equipment if the direction of travel or function engaged does not agree with what is indicated on the controller
- use the crane, hoist, or lifting device to lift, support or transport people
- lift or carry any loads over people
- operate the crane, hoist, or lifting device unless all persons, including the operator, are and remain clear of the supported load and any potential pinch points

- operate a crane, hoist, or lifting device when the device is not centered over the load
- operate a crane, hoist, or lifting device if the chain or wire rope is not seated properly in the sprockets, drum or sheave
- operate any damaged or malfunctioning crane, hoist, lifting device, or other material handling equipment
- change any settings or controls without authorization and proper training
- remove or obscure any warning or safety labels or tags
- leave any load unattended while lifted
- leave power on the radio controlled equipment when the equipment is not in operation
- operate any material handling equipment using a damaged controller because the unit may be unsafe
- operate manual motions with other than manual power
- operate radio controlled equipment when low battery indicator is on



WARNING

THE OPERATOR SHOULD NOT ATTEMPT TO REPAIR ANY RADIO CONTROLLER. IF ANY PRODUCT PERFORMANCE OR SAFETY CONCERNS ARE OBSERVED, THE EQUIPMENT SHOULD IMMEDIATELY BE TAKEN OUT OF SERVICE AND BE REPORTED TO THE SUPERVISOR. DAMAGED AND INOPERABLE RADIO CONTROLLER EQUIPMENT SHOULD BE RETURNED TO MAGNETEK FOR EVALUATION AND REPAIR. FAILURE TO FOLLOW THIS WARNING COULD RESULT IN SERIOUS INJURY OR DEATH AND DAMAGE TO EQUIPMENT.

2.6. TRANSMITTER UNIT

Transmitter switches should never be mechanically blocked ON or OFF. When not in use, the operator should turn the transmitter OFF. A secure storage space should be provided for the transmitter unit, and the transmitter unit should always be placed there when not in use. This precaution will help prevent unauthorized people from operating the material handling equipment.

Spare transmitters should be stored in a secure storage space and only removed from the storage space after the current transmitter in use has been turned OFF, taken out of the service area and secured.

2.7. PRE-OPERATION TEST

At the start of each work shift, or when a new operator takes control of the crane, operators should do, as a minimum, the following steps before making lifts with any crane or hoist:

Test all warning devices.

Test all direction and speed controls.

Test the transmitter emergency stop.

2.8. BATTERIES



WARNING

KNOW AND FOLLOW PROPER BATTERY HANDLING, CHARGING, AND DISPOSAL PROCEDURES. IMPROPER BATTERY PROCEDURES CAN CAUSE BATTERIES TO EXPLODE OR DO OTHER SERIOUS DAMAGE. FAILURE TO FOLLOW THIS WARNING COULD RESULT IN SERIOUS INJURY OR DEATH AND DAMAGE TO EQUIPMENT.

2.9. BATTERY HANDLING

Use only batteries approved by Magnetek for the specific product.

Do not dispose of a battery pack in fire; it may explode.

Do not attempt to open the battery pack.

Do not short circuit the battery.

For intrinsically safe environments only use specified Magnetek intrinsically safe batteries.

Keep the battery pack environment cool during charging operation and storage (i.e., not in direct sunlight or close to a heating source).

2.10. BATTERY CHARGING

For those transmitters equipped with battery chargers, please familiarize all users with the instructions of the charger before attempting to use.

Do not attempt to charge non-rechargeable battery packs.

Avoid charging partially discharged rechargeable batteries to help prolong battery cycle life.

Avoid charging the battery pack for more than 24 hours at a time.

Do not charge batteries in a hazardous environment.

Do not short the charger.

Do not attempt to charge a damaged battery.

Use only Magnetek approved chargers for the appropriate battery pack.

Do not attempt to use a battery that is leaking, swollen, or corroded.

Charger units are not intended for outdoor use. Use only indoors.

2.11. BATTERY DISPOSAL

Before disposing of batteries consult local and governmental regulatory requirements for proper disposal procedure.

2.12. SPECIFIC SYSTEM WARNINGS

Below are some specific operating safety tips that should be strictly followed when operating a Flex Pro system:

1. Check the Status LED on the transmitter for any signs of low battery power (refer to Section 11.1).
2. Check the Status LED on the transmitter for any signs of irregularities (refer to Section 11.1).
3. Make sure the system is not set to the same channel as any other Flex systems in use within a distance of 300 meters (900 feet).
4. Never operate equipment with two transmitter handsets at the same time unless they are programmed to do so.

2.13. FLEX M RECEIVER INSTALLATION



WARNING

BEFORE OPERATING THE RECEIVER FAMILIARIZE YOURSELF WITH ALL SAFETY INFORMATION IN THIS MANUAL, APPROPRIATE MANUAL SUPPLEMENTS AND ANY OTHER LOCAL, STATE, OR FEDERAL RULES OR REGULATIONS ALREADY IN EXISTENCE. FAILURE TO FOLLOW THIS WARNING COULD RESULT IN SERIOUS INJURY OR DEATH AND DAMAGE TO EQUIPMENT.

2.14. PRE-INSTALLATION

1. Transmitter and receiver access code and channel must match before the system will communicate.
2. Be aware of other radio channels in the surrounding area - set your system to a unique channel.
3. Make sure that your equipment is working properly in manual mode prior to system installation.
4. Make sure the power to the receiver is the correct voltage.
5. Disconnect equipment power prior to system installation.

3. GENERAL TRANSMITTER INFORMATION

3.1. EXTERNAL ILLUSTRATION (PRO 12 CONFIGURATION)

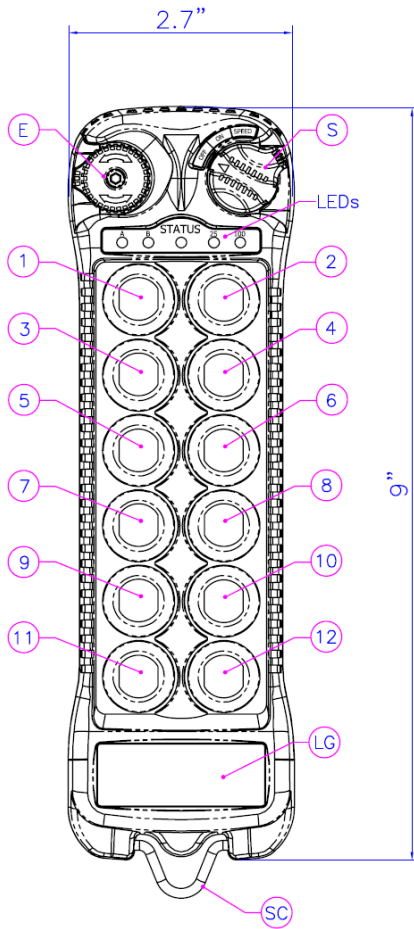

Figure 1

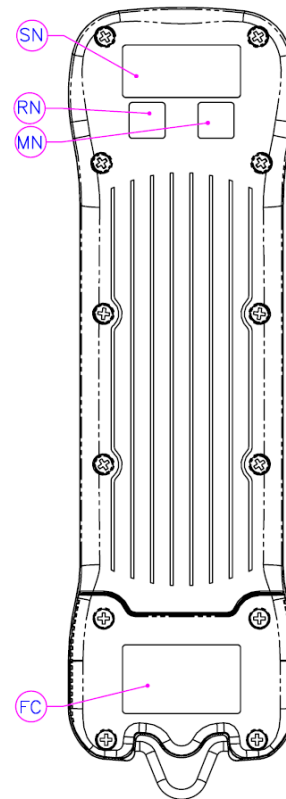

Figure 2

- E. Emergency Stop Button
- S. Removable Power Key Switch
- 1. Push Button #1
- 2. Push Button #2
- 3. Push Button #3
- 4. Push Button #4
- 5. Push Button #5

- 6. Push Button #6
- 7. Push Button #7
- 8. Push Button #8
- 9. Push Button #9
- 10. Push Button #10
- 11. Push Button #11
- 12. Push Button #12

- SC. Strap Ring
- SN. System Information
- RN. System Channel
- MN. Machine Number
- FC. FCC Information

NOTES:

1. Pushbuttons #9 - #12 are not present on the Flex 8 PRO Transmitter
2. Pushbutton #7 on the Flex 8PRO and pushbutton #11 on the Flex 12 PRO can be set to "A / B / BOTH" Select (via dip switch; see Section 4.3)

3.2. INTERNAL ILLUSTRATION (PRO 12 CONFIGURATION)

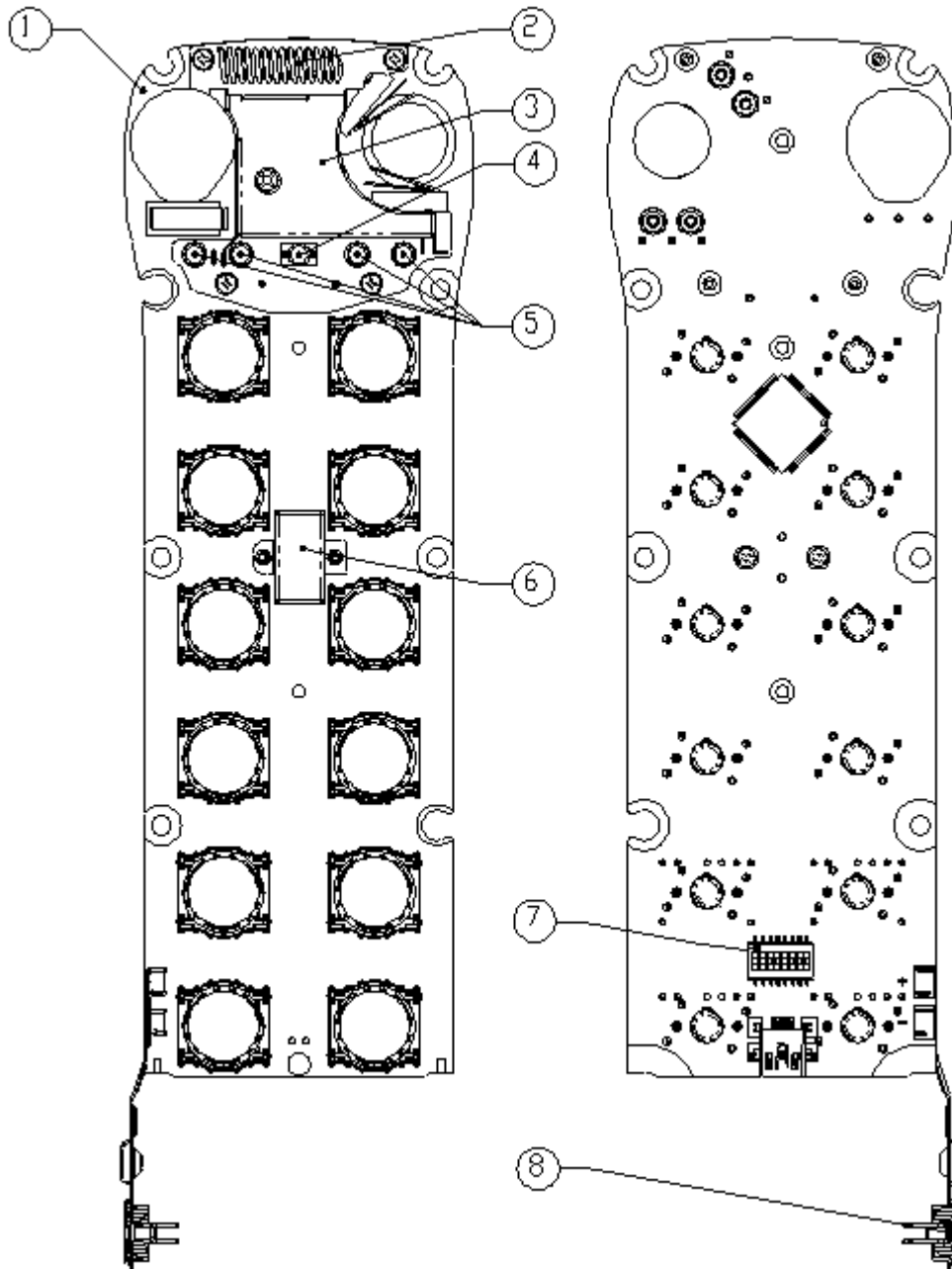

Figure 3

Figure 4

- 1. Encoder Board
- 2. Aerial Antenna
- 3. Transmitting Module
- 4. Status LED Display
- 5. Function LED Displays

- 6. I-CHIP
- 7. Dip-Switch
- 8. Battery Contact Mechanism

NOTE: Flex PRO 8 Module will differ slightly

3.3. TYPES OF BUTTONS

The buttons used on the Flex Pro are fully proportional, stepless push buttons with an output that varies 0-100% (based on how far the button is depressed). Please consult the factory for more information.

3.4. ADJUSTABLE SPEED CONTROL

The proportional buttons normally operate on a scale from 0-100%, but can also be scaled down to operate linearly from 0-25% over the full motion of the button. This gives the user more control over lower speeds. To adjust the speed control settings, press and hold the Start button, then press push button 1 or push button 2 to decrement/increment the range percentage. The red LEDs, which indicate the Speed Setting, will then change to reflect the current setting.

Start +	Speed control setting
PB1	Decrement Speed Control
PB2	Increment Speed Control



Figure 5

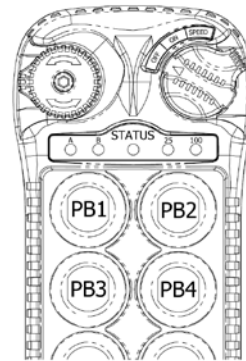

Figure 6

4. DIP SWITCH SETTINGS

4.1. SYSTEM CHANNEL SETTINGS

Set the transmitter channel by adjusting the channel dip-switch located on the backside of the transmitter encoder board (refer to Figure 7 below). Only the first five (5) positions of the dip-switch are used for channel programming (refer to Figure 8 below). The system channels table (Section 5) illustrates which dip-switch setting corresponds to which channel. Once the transmitter channel is altered, you must set up the receiver to recognize the transmitters on its new channel.

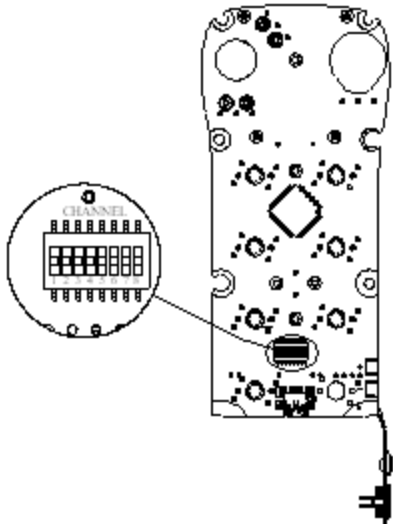

Figure 7

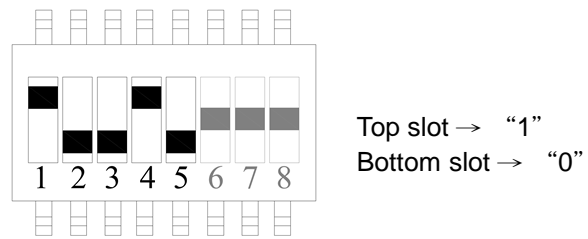

Figure 8

The above dip-switch setting “1 0 0 1 0” corresponds to “channel 19” in the system channels table (Section 5).

4.2. INACTIVITY TIME OUT TIMER

Bits 6 and 7 on the dip-switch allows the user to define a time after which, if no buttons on the transmitter are pressed, the Flex Pro will send an OFF command to the receiver and power down. To restart, the user must turn the On/Off/Start switch to the Off position, then back to On again to resume operation.

Time Out	Dip-switch Setting
5 minutes	01
10 minutes	10
15 minutes	11
Never shut off	00

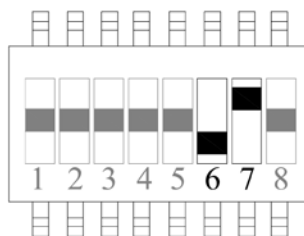

Figure 9

4.3. A/B/BOTH SELECT

Bit 8 on the dip-switch allows the user to set the lower left pushbutton (PB7 on the Flex 8 PRO, PB11 on the Flex 12 PRO) into an A / B / BOTH Select button. When the A / B / BOTH Select button is enabled, it can be used to toggle through the desired outputs as follows: **A > B > BOTH > A ...**

A / B / BOTH	Dip-switch Setting
Enabled	1
Disabled	0

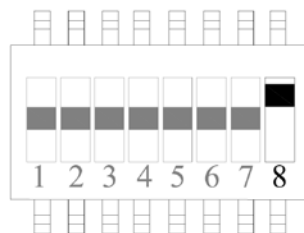

Figure 10

NOTE: When A/B Select function is Enabled, A/B LEDs will be OFF at initial startup, but will remain ON (A, B, or BOTH) once selected. When A/B Select function is disabled, A/B LEDs will remain OFF.

5. SYSTEM CHANNEL TABLE

Channel	Frequency	Dip-switch Setting	Channel	Frequency	Dip-switch Setting
01	433.000MHZ	00000	17	433.800MHZ	10000
02	433.050MHZ	00001	18	433.850MHZ	10001
03	433.100MHZ	00010	19	433.900MHZ	10010
04	433.150MHZ	00011	20	433.950MHZ	10011
05	433.200MHZ	00100	21	434.000MHZ	10100
06	433.250MHZ	00101	22	434.050MHZ	10101
07	433.300MHZ	00110	23	434.100MHZ	10110
08	433.350MHZ	00111	24	434.150MHZ	10111
09	433.400MHZ	01000	25	434.200MHZ	11000
10	433.450MHZ	01001	26	434.250MHZ	11001
11	433.500MHZ	01010	27	434.300MHZ	11010
12	433.550MHZ	01011	28	434.350MHZ	11011
13	433.600MHZ	01100	29	434.400MHZ	11100
14	433.650MHZ	01101	30	434.450MHZ	11101
15	433.700MHZ	01110	31	434.500MHZ	11110
16	433.750MHZ	01111	32	434.550MHZ	11111

6. OPERATING PROCEDURE

6.1. GENERAL OPERATING PROCEDURE

1. Reset the red emergency stop button located on the top left hand side of the transmitter handset by rotating it either clockwise or counter clockwise. The red button will pop up.

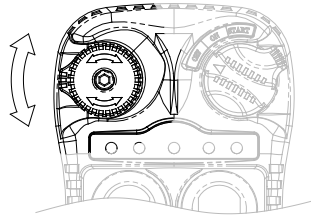

Figure 11

2. Turn on the transmitter power by inserting the black-colored key into the power key slot located on the top right hand side of the transmitter handset and rotate it clockwise to the “On” position.

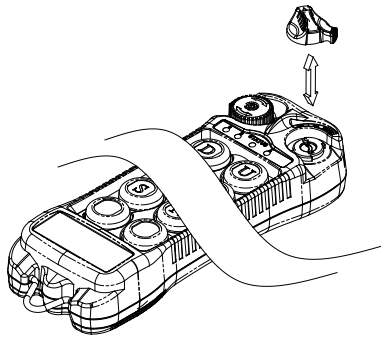

Figure 12

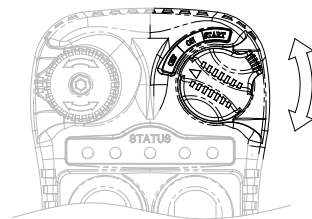

Figure 13

3. After turning on the transmitter power, check the Status LED on the transmitter handset for any sign of system irregularities (refer to Section 11.1). If the system is normal the Status LED will light up green for two (2) seconds, then slowly flash green.

4. If there are no signs of any system irregularities, then rotate the power key further clockwise to the “Start” position for up to 2 seconds. This will activate the receiver E-Stop. Thereafter, the same “Start” position will become an auxiliary function with momentary contact.

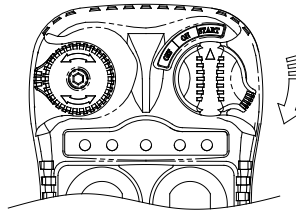

Figure 14

5. Now press any push button on the transmitter handset to operate the equipment. When a button is pressed, the Status LED will flash orange with a variable speed dependent on how far the button is pressed. The further a button is pressed, the faster the LED will flash. When no buttons are pressed, the Status LED will slowly blink green.

6. In case of an emergency, pressing down on the red emergency stop button will immediately disconnect the receiver E-Stop and turn off the unit. To reset the emergency stop button just rotate the red button either clockwise or counter-clockwise and then cycle power to the unit.

7. After a period of inactivity (push button not pressed) defined by the dip switch, the receiver E-Stop will be disconnected and the unit must cycle power before turning on again.

8. Turn off the transmitter power by rotating the power key counter-clockwise to the "Off" position (Status LED becomes a solid red for 4 seconds). This will disconnect the transmitter power and the receiver E-Stop altogether. Turn it further counter-clockwise to release the key.

6.2. CHANGING TRANSMITTER BATTERIES

Change the transmitter batteries by unscrewing the battery cover located on the backside of the transmitter (refer to Figures 15 and 16 below). During battery installation make sure that the ribbon is centered between the two batteries. After changing the batteries also make sure that all screws are tightened to avoid water, moisture, dirt, grease, or other liquid penetration.

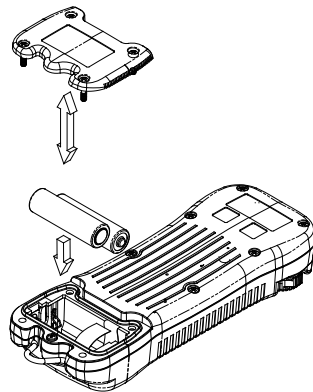

Figure 15

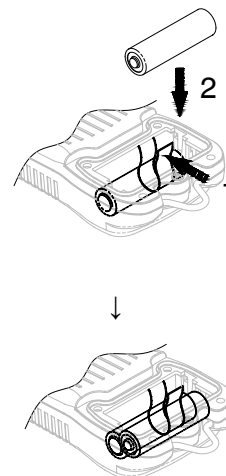
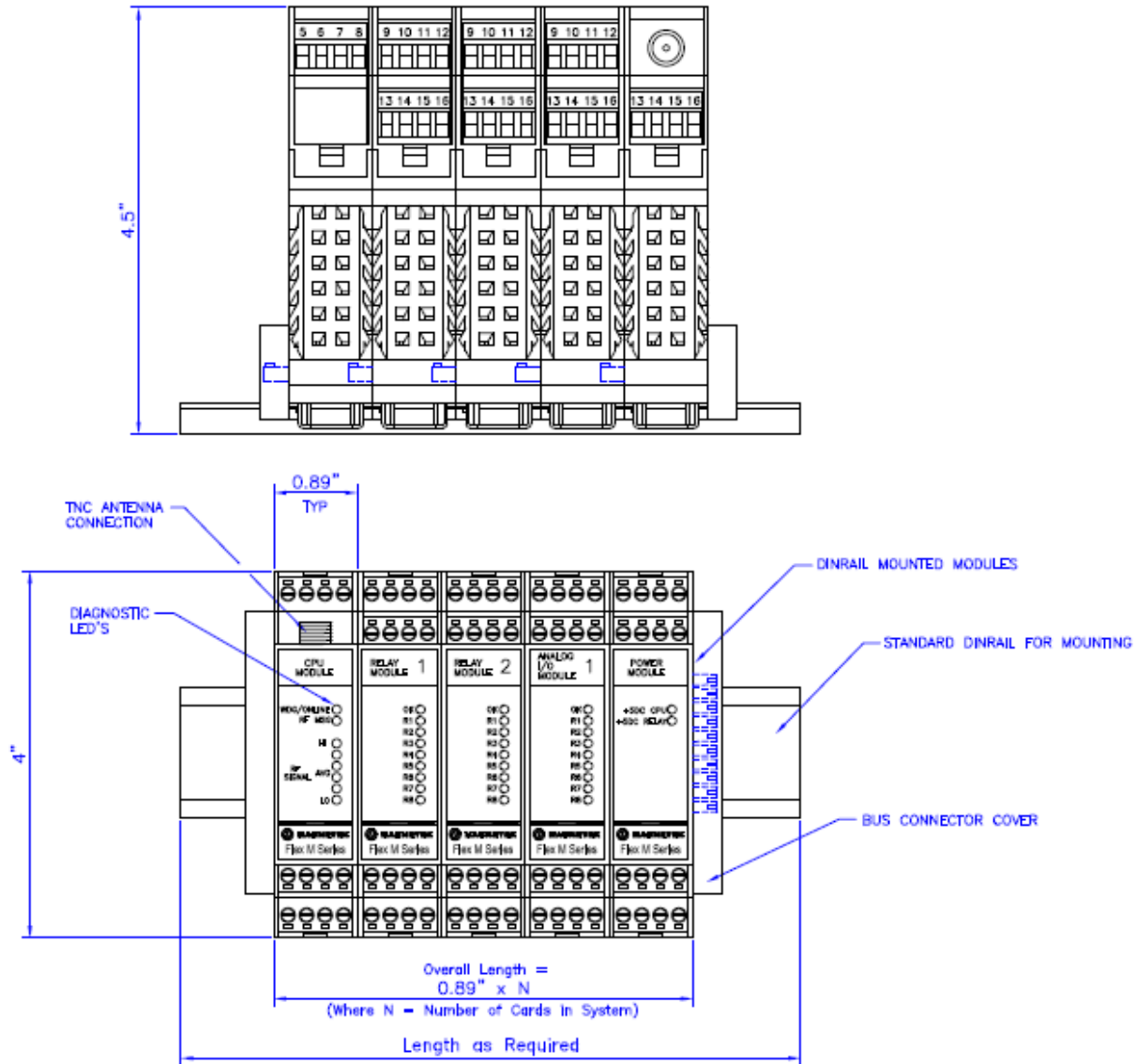

Figure 16

7.0 RECEIVER MECHANICAL DRAWINGS

7.1. MECHANICAL LAYOUTS



FLEXM-24

Figure 17: Mechanical Layout (Flex M-24)

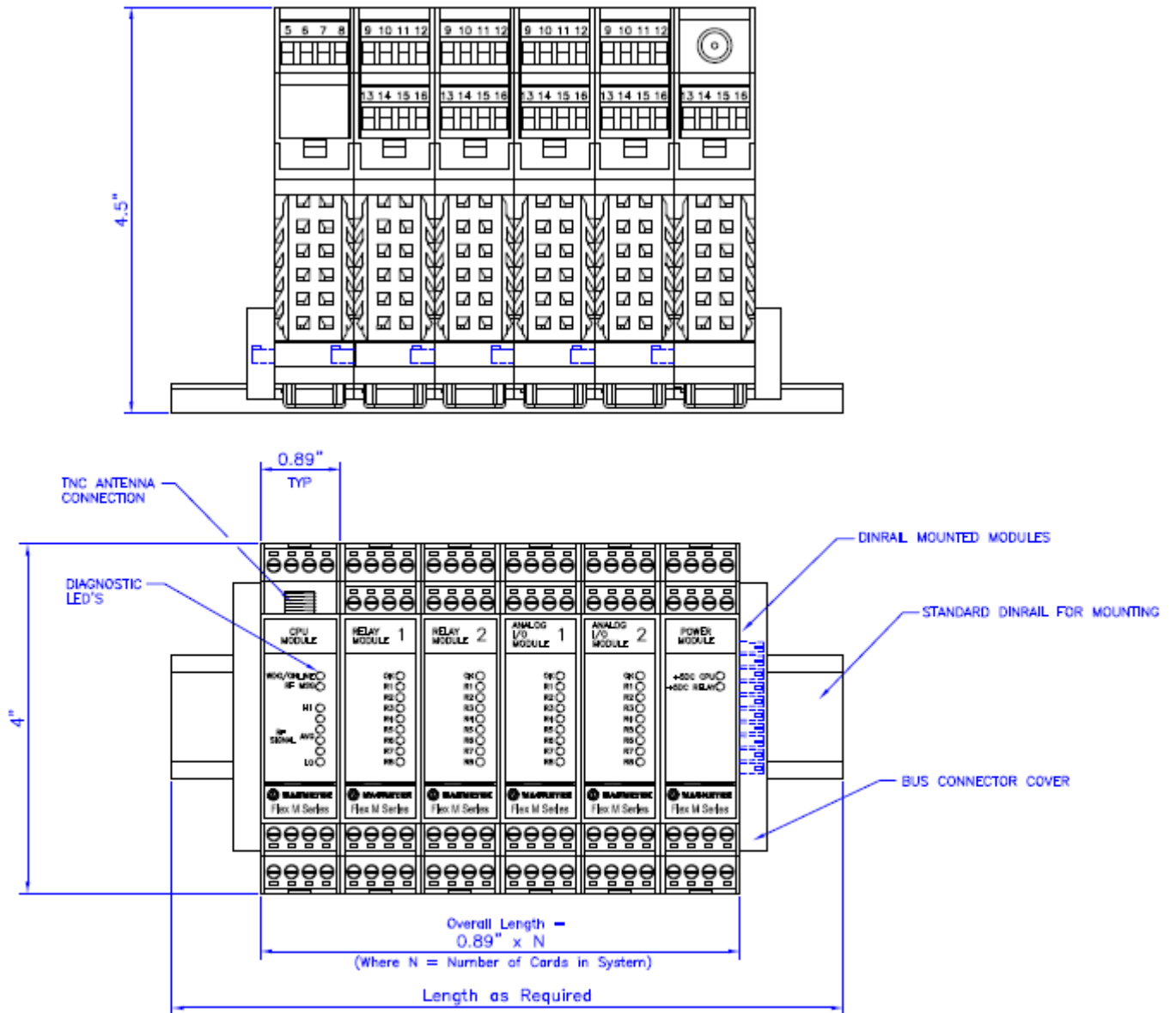

FLEXM-32

Figure 18: Mechanical Layout (Flex M-32)

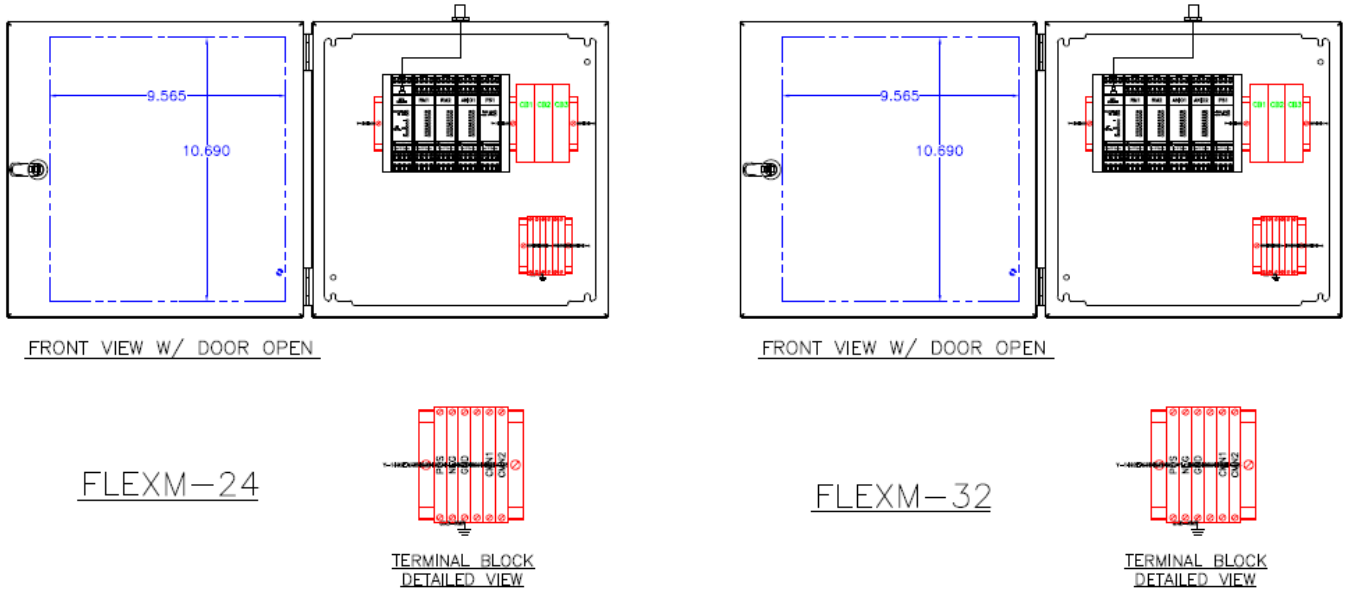

Figure 19: Example of Flex M Receivers Mounted in an Enclosure

7.2. RECEIVER INSTALLATION

1. Be sure to mount the receiver antenna in direct line-of-sight of the operator and free from all obstructions.
2. Do not mount the receiver near high levels of electric noise, such as an unshielded variable frequency drive, as it may cause minor interference. When mounting the Flex M near unshielded variable frequency drive, **Magnetek typically recommends that the Flex M and all antenna cable routing be mounted a minimum of 24 inches from all unshielded variable frequency drives and cables.**
3. Allow adequate room for mounting the receiver. Make sure to allow a minimum of 5" between the connector and nearest surface to allow for cable harness connections.
4. For best reception and to help protect connectors from moisture and water damage, mount the receiver in an upright position. Mount with back flush against a flat surface to protect vents from spray.
5. If obstructions cannot be cleared, or the unit must be mounted inside a metal enclosure, the remote antenna should be used (see Figure 19).
6. Do not enclose the antenna in steel. For the best reception, keep all metal objects away from the antenna. **Consult the factory for more information regarding your application.**
7. The supply power to the Flex M system must have a master disconnect and should be fused.
8. The Flex M modules are installed on a 35mm din rail. To install the individual modules on the din rail, hook the bottom of the module on the din rail and swing the top of the module to the rail until a click is heard or felt.
9. After the modules are placed on the rail, they are slid together so they nest together. Rail clamps are suggested to prevent the module bundle from sliding freely on the rail.
10. Modules **MUST** be installed so that the RF/CPU module is on the left end of the rail and the power supply module is on the right end of the rail.

NOTE: Magnetek strongly recommends the use of external fuses and circuit disconnects for all Flex Modules. Consult factory for more information.

7.3. REMOVAL

1. To remove modules from the rail for service, first ensure all power to the Flex M modules has been turned off and proper lockout/tagout procedures have been followed.
2. Remove one end rail clamp and un-nest the module that you wish to remove by separating it from the others on the rail.
3. Use a slotted screwdriver to lift the exposed metal tab/ring on the top of the module. Swing the module down away from the top tab/ring and unhook from the rail.
4. The PCB from any module can be removed from its housing by pressing in both tabs first (tabs are on the front and back sides of the housing); then the top housing and PCB can be removed from the lower housing (see Figure 20 for details).

Notes:

In order to set dip switches the top along with the printed circuit board need to be removed from the base enclosure. Press in the tabs as shown below to remove the printed circuit board

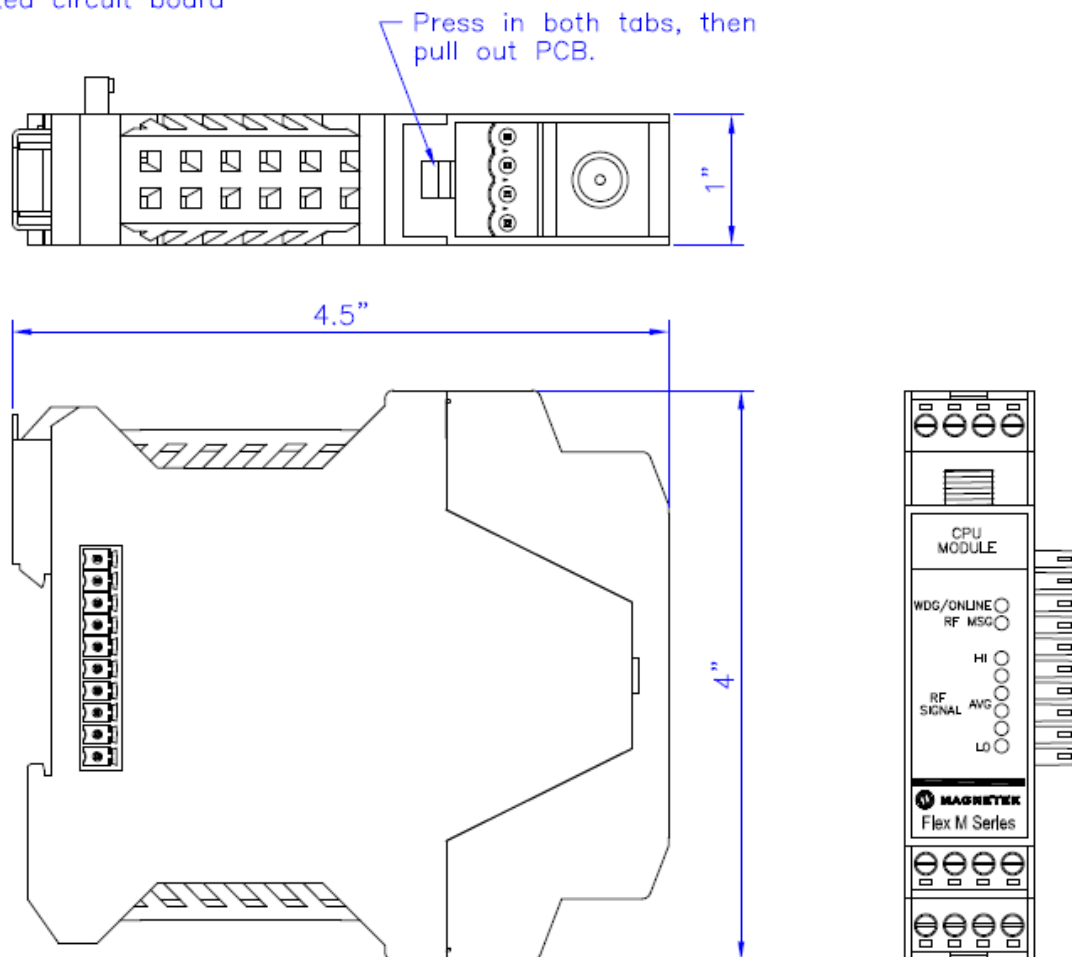

Figure 20: Flex M Housing Removal Detail

8. NORMAL OPERATION

During the operation of the receiver, following the LED indicators will allow observation of the status of the Flex M receiver.

8.1. POWER SUPPLY MODULE

When the Flex M system has power supplied, the two LEDs on the power supply module should be lit and solid.

+5VDC CPU – indicates that +5VDC power is going to the CPU

+5VDC RELAY – indicates that +5VDC power is going to the RELAY modules

8.2. RF/CPU MODULE

When the Flex M system is supplying power to the RF/CPU module, there is a series of LEDs that will indicate the RF/CPU module's status.

WDG/ONLINE LED:

- Solid indicates RF communication with transmitter
- 1 Blink indicates normal operating WDG
- 2 Blinks indicates RF communication loss with transmitter
- 3 Blinks indicates read/write error to an attached Flex M module

RF MSG LED:

- Fast Blinks indicates radio frequency messages received (typical is 4 to 10 messages per second). This confirms communication between transmitter and receiver
- 3 Steady Blinks indicates read/write error to an attached Flex M module
- 4 Steady Blinks indicates an internal radio error

RF SIGNAL LED – measures the strength of the RF communication signal from the transmitter

8.3. RELAY MODULE(S)

When the Flex M system is supplying power to the Relay module, there is an LED that indicates the power and communication status of the Relay module.

OK LED – Solid indicates module communication with system is good

- 3 Blinks indicates read/write error to attached CPU

Additionally, there are 8 LEDs labeled 1 through 8 on the Relay module. When the LED is on, this indicates that the relay is closed/activated.

8.4. ANALOG I/O MODULE(S)

When the Flex M system is supplying power to the Analog I/O module, there is an LED that indicates the power and communication status of the Relay module.

OK LED – Solid indicates module communication with system is good

- 3 Blinks indicates read/write error to attached CPU

Additionally, there are 8 LEDs labeled 1 through 8 on the Analog I/O module. When the LED is on, this indicates that the module is sending/receiving a signal on that input or output.

- LED1 = Analog Output 1 is Active (non-zero)
- LED2 = Analog Output 2 is Active (non-zero)
- LED3 = Analog Output 3 is Active (non-zero)
- LED4 = Analog Output 4 is Active (non-zero)
- LED5 = Analog Input 1 is Active (non-zero)
- LED6 = Analog Input 2 is Active (non-zero)
- LED7 = Analog Input 3 is Active (non-zero)
- LED8 = Analog Input 4 is Active (non-zero)

9. FLEX MODULE TYPES

The Flex M system comprises of a RF/CPU module and a power supply module with application-specific add-on cards in-between the CPU module and power supply module.

9.1. FLEX RF/CPU MODULE

The Flex RF/CPU Module is the main module that receives radio signals from a paired transmitter and interprets those signals into the appropriate response from the attached I/O modules. There is one RF/CPU module in the Flex M System.

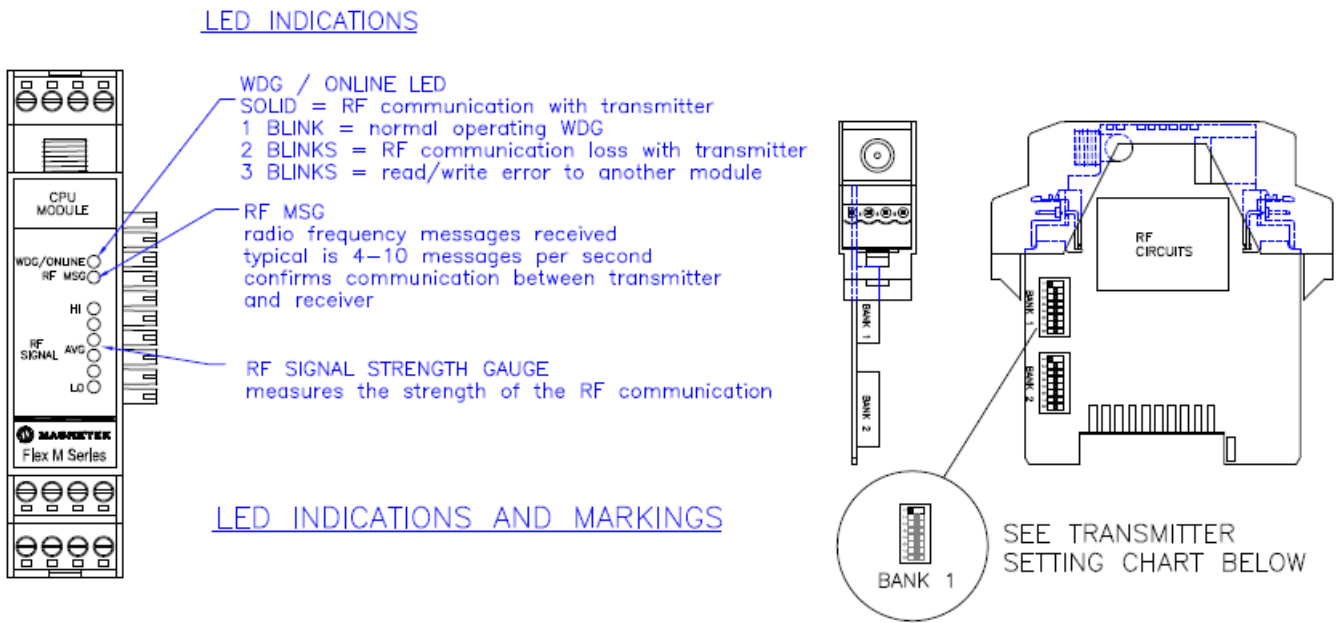
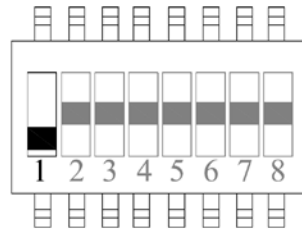

Figure 21: RF/CPU Module Detail View

Bank 1 Dip 1 on the dipswitches is used to set the style of transmitter being used. See chart below for proper settings.

BUTTON SETTING	Dip-switch Setting
12-Button	1
8-Button	0



RF/CPU MODULE	
433MHz Part 15, version 2 RF/CPU Module	25-02-074-816E

9.2. FLEX M POWER SUPPLY MODULE

The Flex M Power Supply Module converts the supply power to 5VDC power for all the attached Flex M modules. This power module has a maximum output supply current of 1000mA. There is one Power Supply Module in the Flex M system.

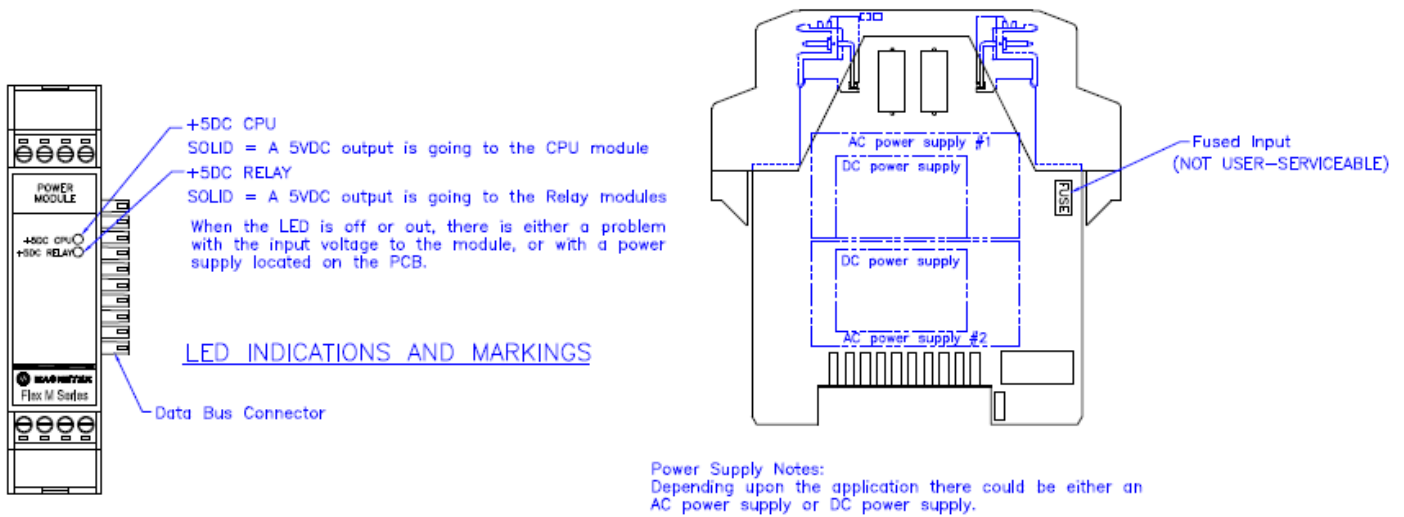

Figure 22: Power Supply Module Detail View

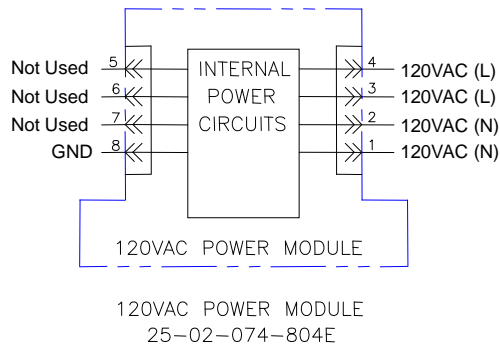

Figure 23: Typical 120VAC Power Wiring

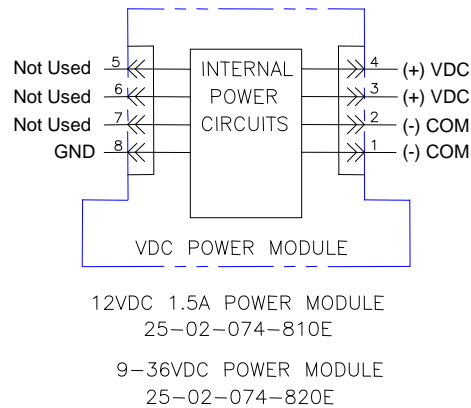

Figure 24: Typical VDC Power Wiring

NOTES:

1. Although the power module has built-in protection, Magnetek strongly recommends the use of external fuses and circuit disconnects for all Flex modules.
2. The built-in fuse is not user serviceable but can be checked if troubleshooting. To check the fuse, remove the power module from the din rail as described in Section 7.2. After removing the module from the din rail, press in the tabs as noted above to remove the PCB from the housing. The fuse location is shown in the PCB view above. Use a multimeter to check for continuity across the fuse. If the fuse is blown, contact Magnetek to send the module in for service.
3. The total system Current Consumption should not exceed the Maximum Output Supply Current of the power supply module. If additional supply current is required, contact the factory for a custom solution.

POWER SUPPLY MODULE OPTIONS			
Description	Minimum Transformer Power Rating	Max Output Current	Part Number
120VAC Power Supply Module	15VA	1000mA	25-02-074-804E
9-18 VDC @1.5A Power Supply Module	25VA	1500mA	25-02-074-810E
9-36VDC Power Supply Module	15VA	1000mA	25-02-074-820E

9.3. FLEX M RELAY MODULE

The Flex M Relay module allows the control of high current power (up to 5A) for attached equipment through 8 relay outputs. Four relays have a common power input and four relays have individually separate power inputs. The relay module number is set by the rotary switch located on the lower left corner of the board.

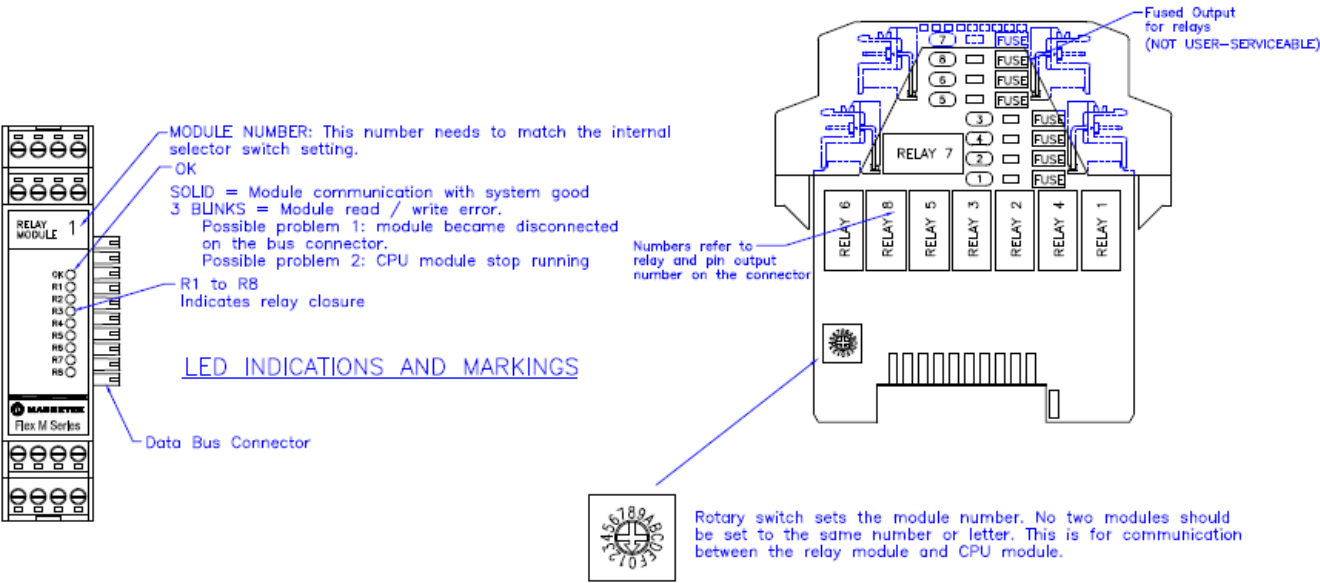

Figure 25: Relay Module Detail View

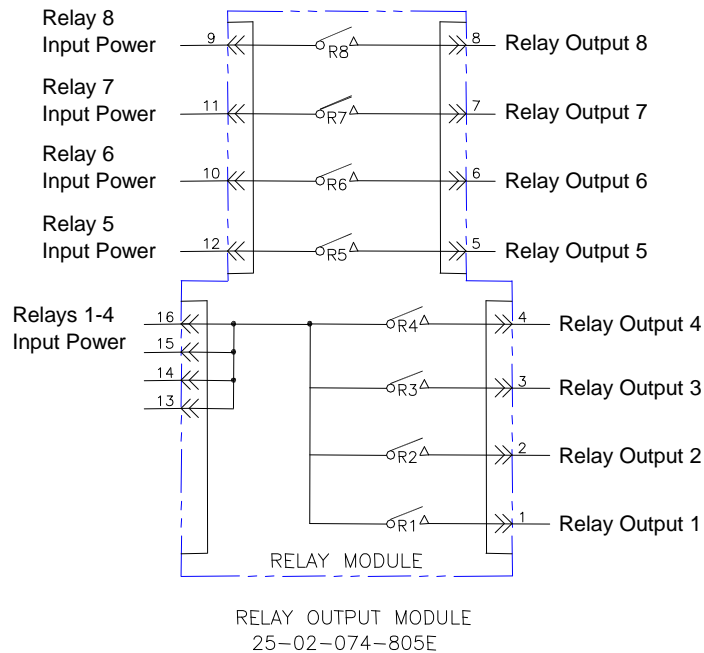

Figure 26: Typical Relay Wiring

9.4. FLEX M ANALOG I/O MODULE

Outputs: The four analog output signals are able to send voltage signals from 0 to +/-10VDC, at an 8bit resolution. These outputs are for reference voltage only, so each one can only supply 20mA of current. The outputs share a common ground reference, which is isolated from the Flex M system ground and any additional I/O card output ground. These outputs can be preconfigured at the factory for different voltage ranges (ex. 0-5VDC, or 3-6-9VDC).

Inputs: The four analog input signals are able to receive voltage signals from 0 to +10VDC, at an 8bit resolution. The input impedance is 20K for these inputs. The inputs share a common ground reference, which is shared with the Flex M system ground.

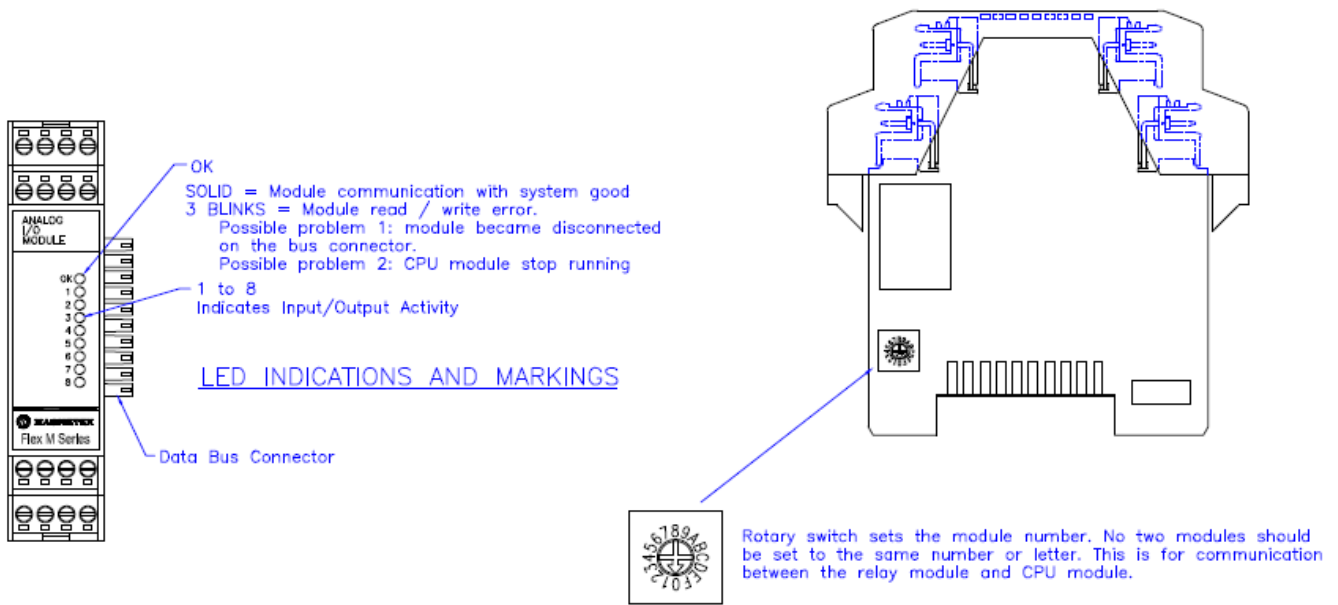

Figure 27: Analog I/O Module Detail View

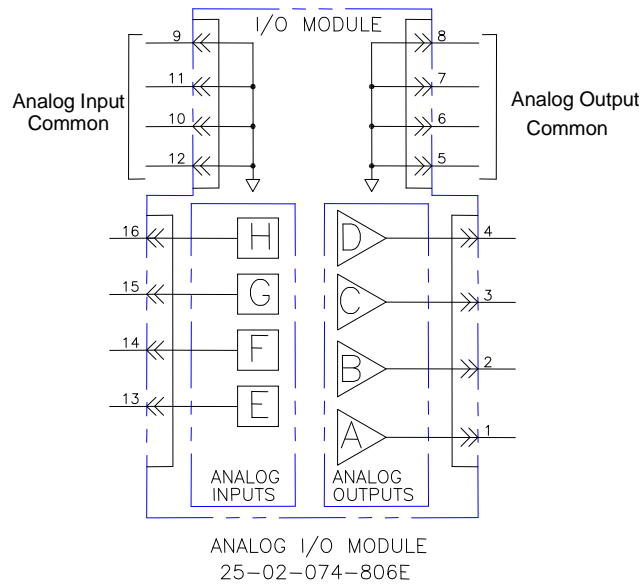

Figure 28: Typical Analog I/O Wiring

10. RECEIVER CHANNEL CONFIGURATION SETTINGS (Bank 2 on RF/CPU Module)

The channel can be set on the RF/CPU module via the Bank 2 dip switches. The following shows the channels or protocols available for each RF/CPU Module option.

NOTE: See Section 7.2 for instructions on how to remove the CPU/RF module from the din rail and how to remove the PCB from the module housing.

10.1. CHANNEL DIP SWITCH SETTINGS FOR 433MHz PART 15, version 2 RF/CPU MODULE (25-02-074-816E)

BANK 2
SWITCH POSITIONS

CHANNEL	SW4	SW5	SW6	SW7	SW8
1 (433.000 Mhz)	DOWN	DOWN	DOWN	DOWN	DOWN
2 (433.050 Mhz)	DOWN	DOWN	DOWN	DOWN	UP
3 (433.100 Mhz)	DOWN	DOWN	DOWN	UP	DOWN
4 (433.150 Mhz)	DOWN	DOWN	DOWN	UP	UP
5 (433.200 Mhz)	DOWN	DOWN	UP	DOWN	DOWN
6 (433.250 Mhz)	DOWN	DOWN	UP	DOWN	UP
7 (433.300 Mhz)	DOWN	DOWN	UP	UP	DOWN
8 (433.350 Mhz)	DOWN	DOWN	UP	UP	UP
9 (433.400 Mhz)	DOWN	UP	DOWN	DOWN	DOWN
10 (433.450 Mhz)	DOWN	UP	DOWN	DOWN	UP
11 (433.500 Mhz)	DOWN	UP	DOWN	UP	DOWN
12 (433.550 Mhz)	DOWN	UP	DOWN	UP	UP
13 (433.600 Mhz)	DOWN	UP	UP	DOWN	DOWN
14 (433.650 Mhz)	DOWN	UP	UP	DOWN	UP
15 (433.700 Mhz)	DOWN	UP	UP	UP	DOWN
16 (433.750 Mhz)	DOWN	UP	UP	UP	UP
17 (433.800 Mhz)	UP	DOWN	DOWN	DOWN	DOWN
18 (433.850 Mhz)	UP	DOWN	DOWN	DOWN	UP
19 (433.900 Mhz)	UP	DOWN	DOWN	UP	DOWN
20 (433.950 Mhz)	UP	DOWN	DOWN	UP	UP
21 (434.000 Mhz)	UP	DOWN	UP	DOWN	DOWN
22 (434.050 Mhz)	UP	DOWN	UP	DOWN	UP
23 (434.100 Mhz)	UP	DOWN	UP	UP	DOWN
24 (434.150 Mhz)	UP	DOWN	UP	UP	UP
25 (434.200 Mhz)	UP	UP	DOWN	DOWN	DOWN
26 (434.250 Mhz)	UP	UP	DOWN	DOWN	UP
27 (434.300 Mhz)	UP	UP	DOWN	UP	DOWN
28 (434.350 Mhz)	UP	UP	DOWN	UP	UP
29 (434.400 Mhz)	UP	UP	UP	DOWN	DOWN
30 (434.450 Mhz)	UP	UP	UP	DOWN	UP
31 (434.500 Mhz)	UP	UP	UP	UP	DOWN
32 (434.550 Mhz)	UP	UP	UP	UP	UP

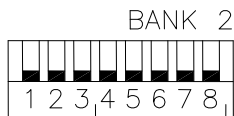

433MHz

10.2. FLEX M 24 AND 32 RELAY PRE-ENGINEERED WIRING

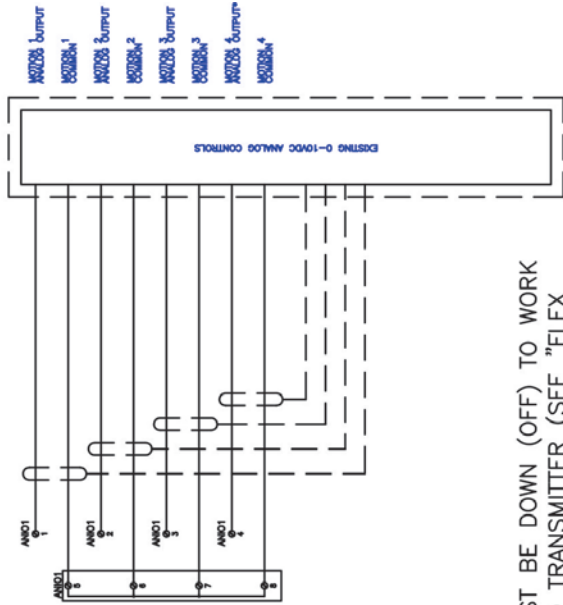

BANK 1 DIP 1 MUST BE DOWN (OFF) TO WORK WITH FLEX 8PRO TRANSMITTER (SEE "FLEX RF/CPU MODULE" SECTION FOR MORE DETAILS)

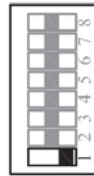

***NOTE:** A/B SELECT OUTPUTS ARE ONLY ACTIVE WHEN SET APPROPRIATELY IN THE TRANSMITTER.

BUTTON 7 OUTPUT IS DISABLED WHEN A/B SELECT OUTPUTS ARE SET TO ACTIVE IN THE TRANSMITTER. MOTION 4 ANALOG OUTPUT IS ALSO DISABLED FOR BUTTON 7 WHEN A/B SELECT OUTPUTS ARE SET TO ACTIVE IN THE TRANSMITTER.

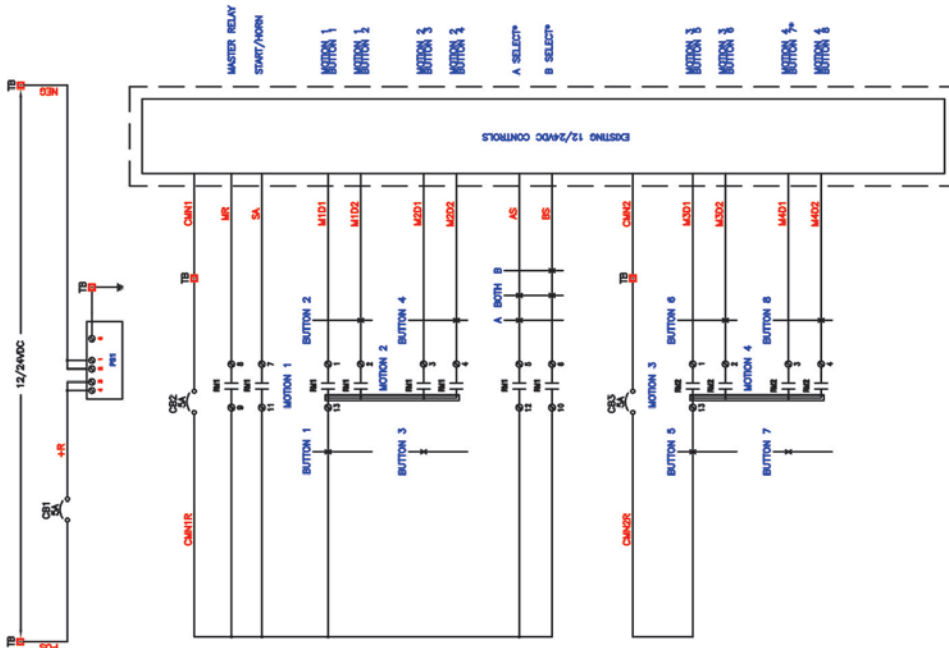

FLEX 8PRO / FLEXM-24

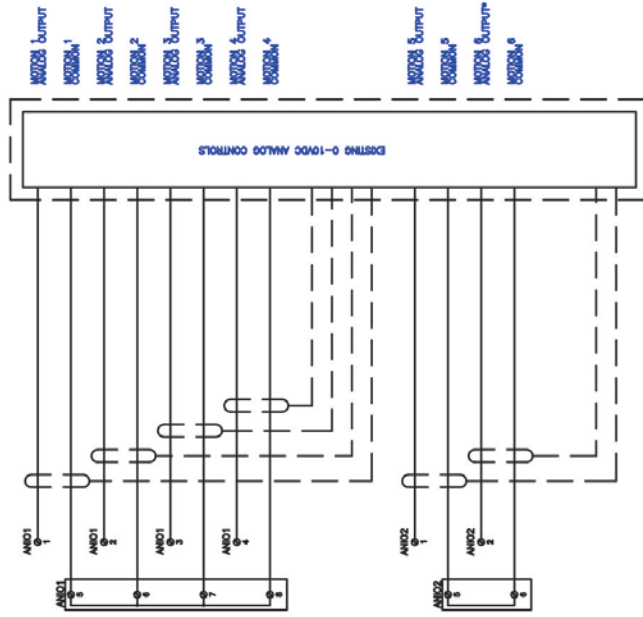
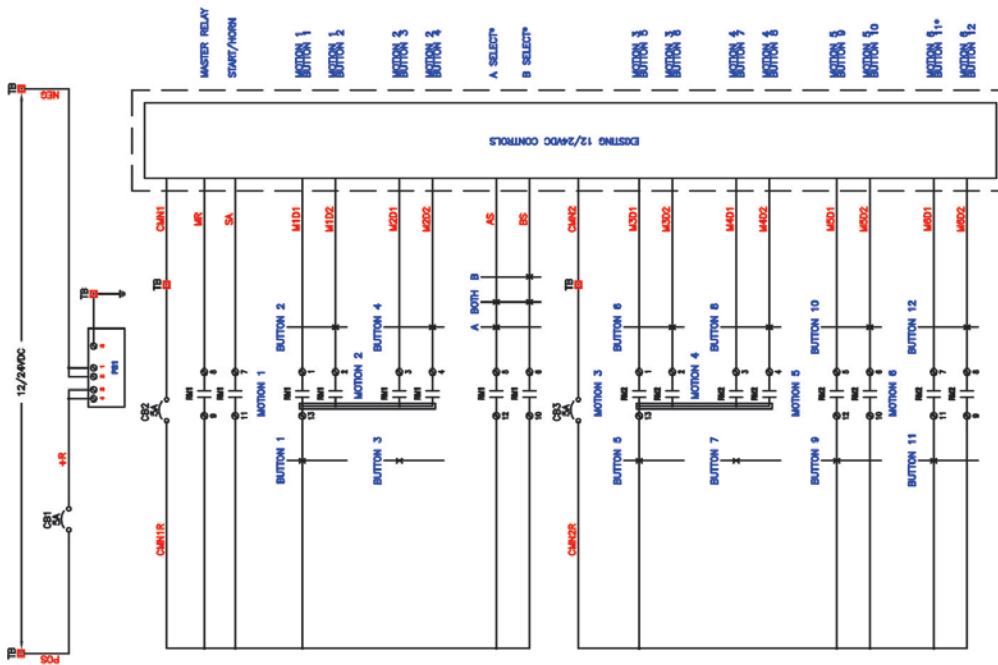

BANK 1 DIP 1 MUST BE UP (ON) TO WORK WITH FLEX 12PRO TRANSMITTER (SEE "FLEX RF/CPU MODULE" SECTION FOR MORE DETAILS)



*NOTE: A/B SELECT OUTPUTS ARE ONLY ACTIVE WHEN SET APPROPRIATELY IN THE TRANSMITTER.

BUTTON 11 OUTPUT IS DISABLED WHEN A/B SELECT OUTPUTS ARE SET TO ACTIVE IN THE TRANSMITTER. MOTION 6 ANALOG OUTPUT IS ALSO DISABLED FOR BUTTON 11 WHEN A/B SELECT OUTPUTS ARE SET TO ACTIVE IN THE TRANSMITTER.

FLEX 12PRO / FLEXM-32

10.3. FCC STATEMENTS

Compliance Statement (Part 15.19)

This device complies with Part 15 of FCC rules.

Operation is subject to the following two conditions:

1. This device may not cause harmful interference, and
2. This device must accept any interference received, including interference that may cause undesired operation.

Warning (Part 15.21)

Changes or modifications not expressly approved by the party responsible for compliance should void the user's authority to operate the equipment.

This portable transmitter with its antenna complies with FCC's RF exposure limits for general population/uncontrolled exposure.

11. TROUBLESHOOTING



WARNING

THE OPERATOR SHOULD NOT ATTEMPT TO REPAIR ANY RADIO CONTROLLER. IF ANY PRODUCT PERFORMANCE OR SAFETY CONCERNS ARE OBSERVED, THE EQUIPMENT SHOULD IMMEDIATELY BE TAKEN OUT OF SERVICE AND BE REPORTED TO THE SUPERVISOR. DAMAGED AND INOPERABLE RADIO CONTROLLER EQUIPMENT SHOULD BE RETURNED TO MAGNETEK FOR EVALUATION AND REPAIR. FAILURE TO FOLLOW THIS WARNING COULD RESULT IN SERIOUS INJURY OR DEATH AND DAMAGE TO EQUIPMENT.

11.1. TRANSMITTER STATUS LIGHT INDICATORS & WARNINGS

Type	Display Type	Indication
1	Slow green blink (Normal Operation)	Transmitter on and in standby.
2	Blinking orange	Button has been pressed and the unit is transmitting. The speed at which the orange LED blinks is directly related to how far down the button is pressed.
3	1 red blink followed by a 2-second pause	Voltage goes below 1.9V during operation - change batteries immediately.
4	2 red blinks followed by a 2-second pause	A push button is active while turning on the transmitter. The button that is active will be designated by the (A, B, 25, 100) LEDs. See Push Button Error Table below.
5	3 red blinks followed by a 2-second pause	I-CHIP error.
6	4 red blinks followed by a 2-second pause	Transmitting error, system cannot lock on to the designated channel.
7	Constant green for up to 2 seconds	Transmitter power on with no faults detected (prior to initiating the START function).
8	Solid Red	Stop command initiated with receiver ESTOP deactivated.
9	Solid Red	Voltage goes below 1.9V at initial power on - transmitter power shuts off.

11.2. TRANSMITTER PUSH BUTTON ERROR TABLE

A	B	25	100	Push Button
OFF	OFF	OFF	ON	1
OFF	OFF	ON	OFF	2
OFF	OFF	ON	ON	3
OFF	ON	OFF	OFF	4
OFF	ON	OFF	ON	5
OFF	ON	ON	OFF	6
OFF	ON	ON	ON	7
ON	OFF	OFF	OFF	8
ON	OFF	OFF	ON	9
ON	OFF	ON	OFF	10
ON	OFF	ON	ON	11
ON	ON	OFF	OFF	12

11.3. TROUBLESHOOTING TABLE

Problems	Possible Reasons	Suggestions
No response when transmitter push button is pressed (Improper startup & settings)	Transmitter low battery power	Check the transmitter battery level.
	Emergency stop button activated prior to startup	Prior to turning on the transmitter power switch make sure that the red emergency stop button is elevated.
	Improper startup procedure	Redo the startup procedure by holding the power key at "START" position for up to 2.0 seconds and then release.
	Incorrect system RF channel	Make sure that the transmitter handset and the receiver unit both have the same channel.
	Incorrect Receiver Access Code	Make sure that the transmitter handset and receiver unit both have the same Receiver Access Code.
	System out of range	Make sure that the startup procedure is initiated within 100 meters (300 feet) from the receiver location.
Receiver will not turn on, +5VDC CPU/RELAY LEDs on Power Supply Module do not light up	Supplied voltage is out of the acceptable range	Ensure the voltage is 120VAC nominal
	Internal fuse has blown on power supply module	Contact the factory for repair
	Internal Power supply on PCB has a problem	Contact the factory for repair
Receiver will not respond to the transmitter	WDG/Online LED on CPU/RF module is blinking 2 times (communication loss with transmitter), and RF MSG LED does not blink.	Make sure the receiver and transmitter unit are both within range. Also verify that the transmitter is still on.
	WDG/Online LED on CPU/RF module is blinking 1 time (normal operating WDG), RF MSG LED does not blink and RF Signal strength LEDs are indicating a signal strength.	Make sure the receiver and transmitter unit have the same access code.
	WDG/Online LED on CPU/RF module is blinking 1 time (normal operating WDG), RF MSG LED does not blink and RF Signal strength LEDs are indicating an erratic signal.	Make sure the receiver and transmitter are both set to the same channel.
	WDG/Online LED on CPU/RF module is blinking 3 times, read/write error with relay modules	Make sure that the modules are securely put together; if the problem persists, contact factory for repair.
	The antenna on the receiver is missing, damaged, or improperly installed.	Inspect the antenna on the receiver for damage and try to place the antenna in a location that is visible when operating the equipment at all times.

Problems	Possible Reasons	Suggestions
Receiver responds to the transmitter inconsistently	The transmitter is going in and out of range (transmitter and receiver are on the edge of the transmission range)	Move the transmitter and the receiver closer together
	The antenna and/or cable on the receiver is damaged, or improperly installed.	Relocate the receiver antenna to where it is in more line of sight with the transmitter
The MLC (Master) Relay turns off during normal operation	The transmitter powered down due to inactivity.	Inspect the antenna on the receiver for damage and try to place the antenna in a location that is visible when operating the equipment at all times.
	The transmitter powered down due to low batteries	Extend the inactivity timeout setting for the transmitter.
	The RF/Message LED stops blinking for more than 3 seconds, followed by the MLC Relay turning off.	Replace the transmitter's batteries.
	The RF/Message LED stopped and the MLC Relay turned off together within 1 sec, possibly when engaging or disengaging another relay that is driving a contactor.	Radio interference; change the system's channel setting.
	The serial data timeout error LED (LED #5) on the serial communication card is lit. Drive serial communication is inactive or was inactive for more than 1 sec. MLC Relay turned off together when LED is lit.	CPU module is resetting. Install snubbers across the coils of all contactors to reduce transient voltages. Ensure that the power module has a stable power source.
		Error is reset when transmitter issues a start command. Inspect serial communication wiring to ensure there are no breaks, poor connections or damage to the wiring.

11.4. ASSEMBLY AND REPLACEMENT PARTS

Description	Part Number
433MHz Part 15, version 2 RF/CPU Module	25-02-074-816E
120VAC Power Supply Module	25-02-074-804E
12VDC @ 1.5A Power Supply Module	25-02-074-810E
9-36VDC Power Supply Module	25-02-074-820E
Relay Module (8 Mechanical relay outputs)	25-02-074-805E
Analog I/O Module (4 0 to +/-10VDC Outputs and 4 0 to +10VDC Inputs)	25-02-074-806E
400MHz Antenna Kit (20' Cable, Antenna and Bracket)	178-01377-0530
400MHz Antenna Kit (20' Cable, 10' Cable, Antenna & Bracket)	178-01377-2530
400MHz Antenna Kit (40' Cable, Antenna and Bracket)	178-01377-0520
400MHz Antenna Kit (40' Cable, 10' Cable, Antenna & Bracket)	178-01377-2520
NEMA 4 Enclosure, Steel (16"x14"x6") for Flex M RX, mounted	20-101-0031E
Module Replacement Plugs	01-300-0031E
Arc Suppressor/Snubbers	20-680-0000E

12. NOTES