

**Mondel Engineering**  
*Hi-TORK™ 300M*  
*Mill Duty Shoe Brakes*

# Mill Duty Shoe Brakes



**MAGNETEK**  **UNCOMMON POWER**

# MONDEL MEANS BRAKES

## Contents and Page Reference Guide

PAGE	DESCRIPTION	TYPE
3	Introduction	-----
4-5	Ordering Information	-----
6-8	DC Magnet Operated Brakes	BE
9-12	3-Phase AC Hy-Thrust Operated Brakes	BT & BTE
12-13	Hydraulic (Pedal) Operated Brakes	BM & BP
14-16	DC Magnetic — Hydraulic Operated Shoe Brakes	BEM
17-19	Hydraulic — 3-Phase AC Hy-Thrust Operated Brakes	BTM & BTME
20-21	Manual Hydraulic Brake System — Type BM, BEM, & BTM Brakes	-----
22	Brake Wheels — Type ABW	ABW
23-24	Brake Wheel Couplings — Gear Type	BWC
25	DC Magnet Brake Rectifiers/Controllers — Type BE & BEM Brakes	ABC, ABR
26	Brake Covers/Enclosures	-----

The information contained in this technical manual is general in nature and shall not be construed to warrant suitability of the equipment for any specific installation or application. All designs, specifications and components of the equipment described are subject to change at Mondel's sole discretion at any time without advance notice.

# Hi-Tork™ 300M Series Mill Duty Shoe Brakes

## Introduction

Magnetek's AISE-NEMA rated Mill Duty Brakes are designed for harsh environments including heavy-duty steel mill applications. Our advanced design features, combined with fabricated steel construction, make this range of brakes suitable for applications requiring reliable braking with minimal maintenance and downtime.

Applications include:

- Steel Mills
- Stacker Reclaimers
- Ship Loaders
- Port Cranes
- Shipyard Cranes
- Offshore Drilling Rigs
- Missile Assembly Cranes
- Incinerator Cranes
- Large Gantry Cranes

### STANDARD FEATURES

- Environmentally safe molded non-asbestos brake linings provide a constant coefficient of friction over the normal operating temperature range.
- Linings are bonded, delivering nearly twice the wear life over riveted or bolted liners.
- Brake shoes are self-aligning.
- Main pivot points are fitted with anti-friction composite bushings.
- DC operators available to meet all AISE-NEMA ratings.
- Series wound coils for all currents
- Shunt wound coils for all popular voltages
- Watertight encapsulated DC coils
- AC operators are C.S.A. certified for all popular voltages and frequencies.
- Top hinged armatures on DC magnets keep air gap free from dirt and debris.
- DC Magnet coils are easily removed without releasing brake torque.
- Class "F" insulation

### BRAKE WHEELS

- Standard finished 300M Series brake wheels meet all AISE-NEMA ratings.
  - Standard wheels are cast in a ductile iron alloy.
  - Wheel material endures high temperatures and is resistant to scoring.
  - Wheels available to meet customers specifications; from fully machined and balanced to semi-finished rough bored.
- (Reference page 22)

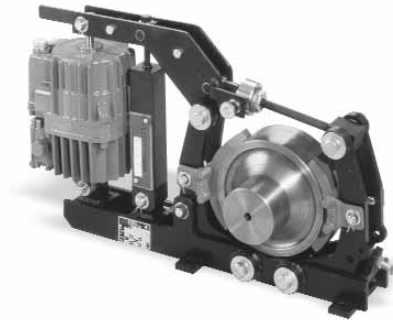

TYPE 8" BTE-ED23/5S(AAE) AC BRAKE

### BRAKE WHEEL COUPLINGS

- Brake wheel couplings available for all sizes of 300M Series brake wheels
- (Reference page 23)

### BRAKE RECTIFIERS AND BRAKE CONTROLLERS

- Rectifiers allow a DC magnet brake to be utilized with an AC power supply
  - Hoist brake rectifiers include a forcing/holding circuit to minimize set and release times
  - Standard controller designed to operate BE Series brake with shunt wound 50 VDC coil
  - Standard controller supplied in a NEMA 3R Enclosure
- (Reference page 25)

### BRAKE ENCLOSURES

- Custom enclosures designed to protect brake from its application environment.
  - Available in NEMA 3R and NEMA 4 design configurations.
- (Reference page 26)

### OPTIONAL FEATURES

- Self-adjustment—keeps brake shoe/wheel gap constant as the shoe linings wear.
- Class "H" insulation
- Mechanical and magnetic proximity interlock/limit switches (BT & BTE models)
- Ceiling or vertical mounting
- Riveted brake shoe linings
- Tropical protection
- Explosion-proof and flame-proof applications
- Pedal operated manual hydraulic over-ride system
- Power assisted hydraulic system
- Remote controlled power assist system

### INSTALLATION, MAINTENANCE & SPARE PARTS

- Specific installation, operation, and maintenance and spare parts list are shipped with each brake.
- Additional copies are available on request or by downloading from the [www.mondelengineering.com](http://www.mondelengineering.com) web site.

# Hi-Tork™ 300M Series Mill Duty Shoe Brakes

## Ordering Information

### ■ GENERAL

The 300M Series of shoe brakes conform to the latest AISE-NEMA standards, which determine items such as:

- Brake wheel diameter
- Brake wheel width
- Torque ratings
- Mounting dimensions
- Brake wheel centerline from mounting surface
- Voltage and current values for brake setting and releasing
- Brake wheel offsets
- Brake wheel bores
- Brake mounting dimension from the motor

When selecting a brake based on AISE-NEMA standards, consideration must be given to the design characteristics and the features/options available on each model of the 300M Series brakes. The size of the brake/brake wheel will be derived by the torque and energy requirements of the load, special engineering or environmental conditions imposed by the application.

### ■ BRAKE SPECIFICATIONS

The brake specification list can be utilized as a guide to the basic information required in choosing a 300M Series brake for your application:

- Brake Wheel Diameter (8", 13", etc.)
- Brake Type (BE, BT, etc.)
- Motor HP
- Motor RPM
- Crane Motion (Hoist, Bridge, Trolley, etc.)
- Power Supply (DC Shunt, DC Series, AC, etc.)
- Motor Data (Make, Frame Size, FLA, etc.)
- Duty Cycle (Operations per hour, etc.)
- Ambient Temp.
- Brake Wheel Diameter (8", 13", etc)
- Brake Wheel Bore Type (Rough, Tapered, Straight, etc.)
- Bore Dimensions (Shaft Size)
- Keyway (Width & Depth)
- Type of Key (Straight, Gib)
- Brake Enclosure (NEMA 3R, 4, other)

### ■ REPLACEMENT BRAKES AND SPARE PARTS

Each brake shipped includes a serial number; if possible please reference the brake type and serial number when making inquiries.

## Explanation of Brake Types

BRAKE TYPE	DC MAGNET OPERATED	3-PHASE AC HY-THRUST OPERATED		HYDRAULIC OPERATED	
		INTERNAL TORQUE SPRING	EXTERNAL ADJUSTABLE TORQUE SPRING	PEDAL	POWER ASSISTED
MBE	■				
MBT		■			
MBT/E			■		
MBM				■	
MBP					■
MBEM	■			■	
MBEP	■				■
MBTM		■		■	
MBTP		■			■
MBTM/E			■	■	
MBTP/E			■		■

### ■ BRAKE ORDERING CODE

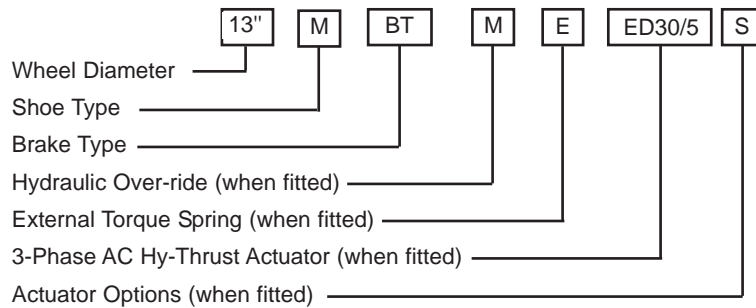

Example: 13" MBTME - Ed 30/5 S consists of a 13" 3-Phase AC Hy-Thrust Brake fitted with standard shoes, manual (pedal) operated hydraulic over-ride, external torque spring and adjustable time delay on actuator setting stroke.

### ■ TYPICAL BRAKE CODES

- 13" BE Basic DC Brake
- 13" BEM Basic DC Brake plus: (M) pedal operated hydraulic override
- 13" BM Basic Pedal Operated Hydraulic Brake
- 13" BT - Ed 30/5C Basic AC 3-Phase Brake fitted with (C) Internal Torque Spring
- 13" BT/E - Ed 30/5S Basic AC 3-Phase Brake fitted with (E) External Torque Spring and (S) adjustable time delay on setting stroke

# Hi-Tork™ 300M Series

## Type “BE”—DC Magnet Operated Brakes

The “BE” type brake is a spring applied, electrically released DC shoe brake designed to meet and exceed the latest AISE-NEMA specifications for mill, crane and other heavy-duty industrial applications. These brakes will provide a long service life with a minimal amount of maintenance and downtime.

### ■ CONSTRUCTION

- The brake base, shoe holders and the shoes are manufactured from ductile iron.
- Fabricated steel linkages
- The magnet case and armature are made of cast steel.
- All brake hardware is corrosion resistant.
- Composite bushings utilized in all main pivot points.
- The “floating-linkages” provide positive braking action with equal lining wear.
- Molded brake linings are non-asbestos and provide a constant coefficient of friction at normal operating temperatures.
- Shoe linings are bonded to the shoes delivering nearly twice the life over riveted or bolted liners.

### ■ STANDARD FEATURES

- Top hinged magnet prevents dirt and debris build up between the magnet case and the armature.
- Worn brake shoes may be replaced in minutes without disassembling the brake linkage assembly.
- Anti-friction composite bushings utilized in all main pivot points for improved impact resistance.
- Class “F” insulation
- Easily replaceable magnet coil. May be replaced without the loss of brake torque.
- Watertight coil and terminal box
- Brake shoes are easily replaced from either side of the brake.
- Self aligning brake shoes—prevents wheel drag.
- Auto-Equalization—air gap between armature and magnet is automatic.
- Emergency brake release
- Floor mounting

### ■ OPTIONAL FEATURES

- Class “H” insulation
- Patented Self-Adjustment for the brake shoes maintains shoe clearance while minimizing impact loading of pivot points.
- Manual latching brake release lever
- Armature position indicator switch
- Wall and ceiling mounting configurations (consult factory)

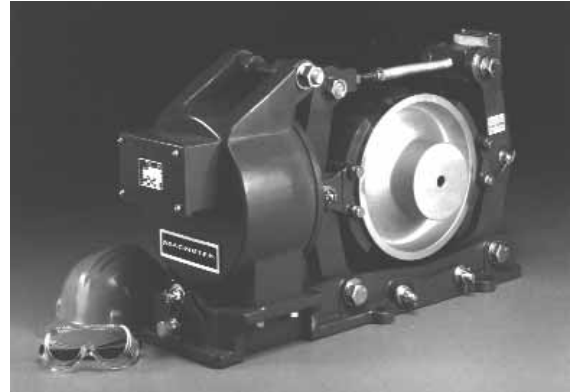

TYPE 13" BE ELECTRIC SHOE BRAKE

### ■ OPERATING MAGNET

The magnet case is bolted to the base of the brake and is hinged at the top of the magnet case. When the magnet is energized, the armature moves to compress the torque spring. The shoes move away from the wheel and the brake is released. When the magnet is de-energized, the opposite actions take place and the spring applies torque to the brake wheel through the linkages and shoes. The Auto-Equalization feature maintains the air gap between the armature and the magnet to optimize response time and reduce impact stresses.

### ■ BRAKE COILS

The brake coil is made from “H” insulated magnet wire. The coil is encapsulated with a high temperature thermo-setting compound to prevent the ingress of dirt, moisture, oil, etc., insuring a long reliable service life.

## VOLTAGES

Shunt coils are available for a wide range of voltages for continuous (8 hour) or intermittent (1 hour) 50%, duty cycles. The coils are designed to release at 80% of line voltage. When selecting shunt brakes for fast operation on DC systems, specify system voltage and use 1/2 the voltage coil with series resistance. Series coils are available for the complete range of currents. The series brake is designed to release at 40% and hold at 10% of the full load motor current. The torque ratings obtained by the coils comply with the latest AISE-NEMA standard. For special voltages for applications, please contact the factory.

## AC STATIC RECTIFIER

On AC powered equipment where customers prefer a DC brake, an AC/DC controller can be provided. This unit includes a transformer, rectifier, brake contactor, protective fusing and a static brake control timer board. The standard controller is mounted in a NEMA 3R Enclosure or on a panel for mounting inside customers existing equipment. Standard units are suitable for 230/460/575—3ph—60Hz power supplies. For special voltages, frequencies or other applications, please contact the factory.

## PATENTED SELF-ADJUSTMENT FEATURE

You never need to adjust this brake for lining wear! It adjusts itself. No troublesome mechanical linkages, star wheels, or other devices for brake adjustment are required. The simple, automatic, dependable way in which the adjustment is accomplished is explained and illustrated below.

Each time the brake is released, the end stop, attached to the brake rod, moves slightly to the right through the pivot block, adjusting plates and plate enclosure. If the brake linings have worn enough so that an adjustment is required, the end stop will move far enough so that an adjusting plate can drop from its upper position to its lower position around the brake rod. Since this adjusting plate is between the end stop and the pivot block, it shortens the effective travel of the brake rod on application so that the brake is adjusted correctly.

In this way the brakes self-adjust throughout the full thickness of the linings or until the linings are replaced. This feature delivers increased productivity and decreased maintenance time. It also protects the entire brake assembly from the impact loads that can become excessive as the gap between the shoes and the wheel increases.

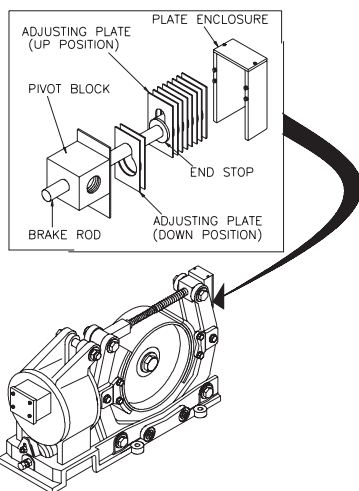

## BRAKE SELECTION AND APPLICATION

Please refer to the next page for technical, dimensional information on the 300M Series “BE”—DC Magnet Operated Brakes. If you have an unusual application or require assistance in selecting the appropriate brake, please contact Magnetek’s Application Sales Department.

# Hi-Tork™ 300M Series

## Type "BE"—DC Magnet Operated Brakes

### Dimensions and Ratings

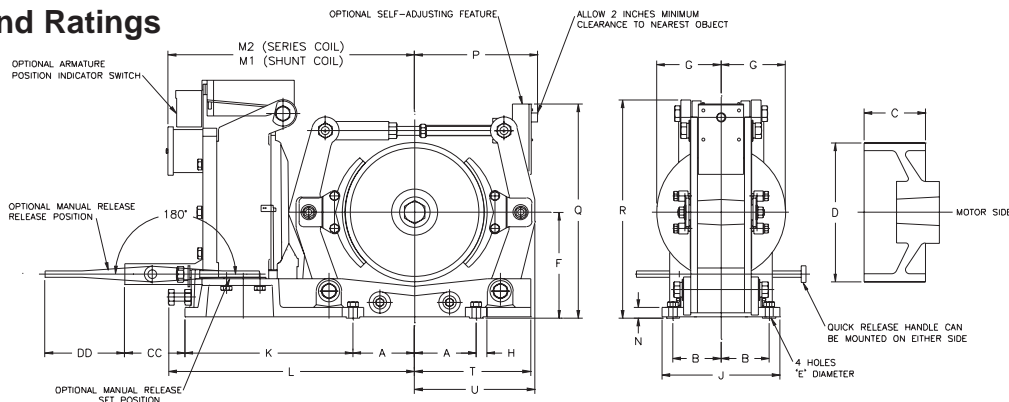

### Approximate Dimensions (inches)

CATALOG	A	B	C	D	E	F	G	H	J	K	L	M1	M2	N	P	Q	R	T	U	CC	DD
5" BE (4)	4.19	2.44	2.75	5.00	0.44	4.06	3.50	0.50	5.88	7.44	12.88	13.38	—	0.47	6.25	8.59	9.59	4.69	4.56	3.94	4.25
8" BE	3.25	2.88	3.25	8.00	0.69	7.00	4.00	0.75	7.25	12.25	17.44	17.69	17.69	0.81	7.56	13.31	13.13	6.88	7.00	4.56	4.88
10" BE	4.00	3.13	3.75	10.00	0.69	8.38	4.84	0.88	8.00	13.97	19.81	19.38	19.81	0.84	9.38	16.38	16.19	8.35	8.63	4.84	4.62
13" BE	5.75	4.50	5.75	13.00	0.81	9.88	6.28	1.00	11.00	15.69	23.90	23.00	25.00	1.00	11.50	20.00	20.38	10.84	11.25	5.62	7.44
16" BE	7.50	5.38	6.75	16.00	1.06	12.13	7.09	1.25	13.25	18.81	28.16	27.19	29.31	1.19	15.00	24.47	24.00	13.63	13.88	6.63	8.75
19" BE	9.25	6.50	8.75	19.00	1.06	13.25	8.69	1.75	15.63	22.31	33.25	32.00	34.00	1.38	17.63	28.25	27.63	18.50	16.63	6.50	12.75
23" BE	11.75	8.00	11.25	23.00	1.31	15.88	11.13	1.75	19.50	23.88	38.50	36.56	38.50	1.50	20.00	32.81	32.13	19.75	19.50	8.00	20.00
30" BE	15.00	9.50	14.25	30.00	1.56	20.75	13.94	2.00	23.00	30.25	48.75	48.75	51.00	1.25	25.75	44.06	43.06	26.75	25.50	11.88	30.88

### Rating Data AISE-NEMA Fitted with molded non-asbestos linings

For construction purposes request certified drawing

CATALOG #	BRAKE WHEEL DIAMETER D	TORQUE RATINGS (LB. FT.) (3)						WK <sup>2</sup> OF BRAKE WHEEL (LB. FT. <sup>2</sup> )	BRAKE WHEEL RPM (MAX)	BRAKE SHIP WEIGHT (LBS.)
		SHUNT		SERIES		RECTIFIER OPERATED				
		CONTINUOUS (8 HOUR) DUTY	1-HOUR (50%) DUTY CYCLE	1-HOUR (50% DUTY CYCLE) (1)	1/2 HOUR (30% DUTY CYCLE) (1)	8-HOUR (100% DUTY CYCLE) (2)	1-HOUR (50%) DUTY CYCLE			
			8-HOUR (100% DUTY) HI-SPEED FORCED				8-HOUR (100% DUTY) HI-SPEED FORCED			
5" BE (4)	5"	30	40	26	40	30	40	0.25	9400	98
8" BE	8"	75	100	65	100	75	100	1.25	5870	135
10" BE	10"	150	200	130	200	150	200	2.8	4700	206
13" BE	13"	400	550	365	550	400	550	12	3600	405
16" BE	16"	750	1000	650	1000	750	1000	29.5	2940	675
19" BE	19"	1500	2000	1300	2000	1500	2000	74.2	2470	1150
23" BE	23"	3000	4000	2600	4000	3000	4000	155.6	2040	1833
30" BE	30"	6750	9000	6000	9000	6750	9000	880	1340	3770

### Rating Data General Purpose (Heavy Duty) Fitted with molded non-asbestos linings

5" BE	5"	40	40	40	40	40	40	0.25	9400	98
8" BE	8"	100	120	75	120	100	120	1.25	5870	135
10" BE	10"	200	240	165	240	200	240	2.8	4700	206
13" BE	13"	550	660	430	660	550	660	12	3600	405
16" BE	16"	1000	1200	770	1200	1000	1200	29.5	2940	675
19" BE	19"	2000	2650	1750	2650	2000	2650	74.2	2470	1150
23" BE	23"	4000	4800	3200	4800	4000	4800	155.6	2040	1833
30" BE	30"	9000	11000	7200	11000	9000	11000	880	1340	3770

RATINGS SHOWN FOR 8-HOUR, 1-HOUR AND 1/2-HOUR ARE THE THERMAL RATINGS OF THE COIL. THE TORQUE RATINGS APPLY AT A WORN LINING CONDITION DEFINED AS THE POINT WHERE THE BRAKE READJUSTS, OR WHERE ADJUSTMENT IS REQUIRED AS RECOMMENDED BY THE BRAKE OPERATING INSTRUCTIONS.

- The duty cycles apply to the 1-hour and 1/2-hour ratings provided the on-time does not exceed 10 minutes.
- Rectifier operated brakes are used with an AC power source and are provided with DC shunt release coils maximum 7 1/2 operations per minute.
- Brake selection should be based on torque and duty. When braking service is severe, the WK<sup>2</sup> of the load speed of the brake wheel and maximum number of stops per minute should be submitted to the factory for recommendation. In high cycle applications the brake may have to be sized for heat dissipation in the wheel rather than the thermal capacity of the coil.
- AISE-NEMA does not define a 5-inch size brake.



# Hi-Tork™ 300M Series

## Type “BT”–3-Phase AC Hy-Thrust Operated Brakes

The BT (and BT/E) type, 3-phase AC shoe brakes are spring applied—electrically released by a completely sealed, continuously rated, Hy-Thrust Actuator. The brakes are designed to meet the latest AISE-NEMA specifications for mill, crane and other heavy duty applications. These brakes are designed with a minimum number of parts to provide a long service life with reduced maintenance and downtime.

This versatile brake, with its many standard and optional features, can be applied to a wide range of applications and environmental conditions, where smooth, responsive stopping and holding is required. The cushioned brake action produces significantly fewer mechanical oscillations as compared to the DC Armature or the AC Solenoid type brakes. The latter are expensive to maintain in terms of spare parts replacement and downtime. The inherent cushioning effect makes the brake ideal for high duty cycle or jogging applications, virtually eliminating the mechanical shock loading which can lead to increased component wear and or component failures.

Since the growth in popularity of AC controlled cranes, this brake has rapidly become the standard for all crane motions. It has the same high reliability normally associated with DC clapper brakes, but does not require an expensive transformer/rectifier to supply the DC power and improve the brake response times.

### CONSTRUCTION

- The shoe holders and the shoes are manufactured from ductile iron.
- Fabricated steel linkages
- The actuators are manufactured of a cast aluminum alloy; include double shaft seals, gasketed joints and terminal box, making the units waterproof and dustproof (IP 65).
- All brake hardware is corrosion resistant.
- Composite bushings utilized in all main pivot points.
- The “floating-linkages” provide positive braking action with equal lining wear.
- Molded brake linings are non-asbestos and provide a constant coefficient of friction at normal operating temperatures.
- Shoe linings are bonded to the shoes delivering twice the life over riveted or bolted liners.

### STANDARD FEATURES

- Internal torque springs — Type BT
- Main pivot points are fitted with anti-friction composite bushings.
- Replaceable, waterproof Hy-Thrust Actuator
- Environmentally-safe molded non-asbestos brake linings provide a constant coefficient of friction over the normal operating temperature range.
- Easily replaceable brake shoes from either side of brake
- Brake shoes are self-aligning.
- Convenient manual adjustment for lining wear
- Manual release lever
- Floor mounting

### OPTIONAL FEATURES

- External torque springs — Type BTE
- Time delays on brake setting (“S”) and release (“H”)
- Self adjustment for lining wear
- Hydraulic, pedal operated manual override systems
- Power assist hydraulic override



TYPE 10" BTE–Ed23/5C AC HY-THRUST BRAKE

### TORQUE ADJUSTMENT OPTIONS

The standard Type “BT” (Internal torque spring):

- Torque spring compression rating is fixed within the thruster.
- Pre-set torque setting provided by pull rod pivot pin and thruster pivot pin locations (4).
- Torque may be reduced to 60% of maximum rating - contact factory for additional information.

The optional Type “BTE” (External torque spring):

- Provides stepless torque adjustment
- Torque adjustment made by rotating the nut atop the spring tube assembly
- Torque may be reduced to 40% of maximum rating.
- The actual setting can be read on the calibrated torque indicator (C.T.I.) located in the side of the spring tube assembly.

### RESPONSE TIME

When used on crane bridge motions, it is acceptable to connect the Hy-Thrust actuator directly across the bridge motor terminals. For crane hoist applications, we recommend the Hy-Thrust Actuator is connected directly to the AC supply and switched by a suitable 3-phase contactor. To reduce the response time an additional 15%, motor capacitors must be connected in parallel with the motor windings, and the actuator must be switched through a contactor. A typical application for this arrangement would be container cranes or similar applications.

### SELF-ADJUSTING

Both the “BT” and the “BTE” type actuator brakes can be fitted with an optional device which automatically compensates for lining wear throughout the full thickness life of the linings. The self-adjusting feature consists of a one-way operating clutch, mounted on a special pull-rod, which replaces the standard pull-rod assembly. As the brake linings wear, the actuator stroke increases. This increased movement will cause a pin mounted on the brake linkages to rotate the clutch/pull-rod assembly a few degrees. This rotation draws the brake arms slightly closer together, compensating for the wear in the brake shoe linings. The optional self-adjusting feature eliminates the time required to manually adjust the linkages for brake shoe lining wear. It does not reduce or eliminate the planned maintenance inspections as recommended in the Operation and Maintenance manual provided with the brake.

# Hi-Tork™ 300M Series

## Types “BT” & “BTE”—3-Phase AC Hy-Thrust Operated Brakes

### HY-THRUST ACTUATOR

The Hy-Thrust electro-hydraulic actuators are proven, high performance, reliable units that will provide years of trouble-free service in tough operating conditions. The major components of the actuator are a 3-phase motor, centrifugal pump and a servo-cylinder with a piston. Various types of fluids provide the operating medium and all the units are filled with the appropriate fluid at the factory. The impellor runs freely inside the cylinder and even if the piston rod is not allowed to complete its stroke, the motor is not subject to an overload condition. The impellor is designed with unidirectional blades. This means that the 3-phase connections must be made in accordance with the wiring diagrams illustrated in the Installation and Maintenance Instructions.

### STANDARD FEATURES

- Fast response times
- High switching frequency — 1200 to 2000 operations/hour
- Long service life — 20 million switching cycles
- Working fluid operating range — -13° F (-25° C) through 122° F (+50° C)
- Built-in compression spring (Standard “BT” Type)
- Available for 230VAC, 460VAC, 575VAC/3Ph/60Hz as standard

### OPTIONAL FEATURES

- Stepless, externally adjustable time delays, Setting (“S”), Releasing (“H”), or Both (“HS”)
- Special fluids for operating in extreme ambient temperatures
- External torque springs (“BTE” Type)
- Tropicalized
- Corrosion Protection
- Stator completely encapsulated into motor housing under vacuum
- Explosion-proof and flame-proof units

### ELECTRICAL DESIGN

#### Motor

- 2-pole, 3-phase AC squirrel cage
- Class F insulation standard (Class H optional)
- Continuous rating
- Integral terminal box with gasketed cover plate (IP 65)
- Terminal block 6-pole
- Cable entry 3/4” NPT

#### Power Supply

- 230VAC, 460VAC, 575VAC/3ph/60Hz Standard
- All units connected in Star (Y) configuration
- Special voltages and frequencies available
- DC Voltage actuators are available (Contact Factory)
- Single-phase actuators are Not Available

### MOTOR OPERATING CURRENTS (68° F/20° C)

Thruster	230/3/60 Volts	460/3/60 Volts	575/3/60 Volts
ED 23	0.88 Amps	0.44 Amps	0.38 Amps
ED 30	0.76	0.38	0.33
ED 50	0.86	0.43	0.37
ED 80	2.2	1.1	0.96
ED 121	2.2	1.1	0.96
ED 201	2.4	1.2	1.2
ED 301	2.6	1.3	1.1
ED 185	2.4	1.2	1.0

### WORKING FLUID

#### Standard

Shell Morlina C10

- Ambient operating temperature range -13° F (-25° C) through 122° F (50° C)

#### Optional

Baysilone M20

- Ambient operating temperature range -40° F (-40° C) through 176° F (80° C)

### TIME DELAYS ON BRAKE SET AND RELEASE

Catalog #	Time to Extend (Sec)		Time to Retract (Sec)	
	Without Valve	With Valve	Without Valve	With Valve
ED 23/5	0.4	0.7---6.0	0.4	0.6---6.0
ED 30/5	0.4	0.5---8.0	0.4	0.5---8.0
ED 50/6	0.5	0.7---10.0	0.4	0.5---8.0
ED 80/6	0.4	0.5---8.0	0.4	0.4---8.0
ED 121/6	0.4	0.5---8.0	0.5	0.5---10.0
ED 201/6	0.5	0.7---10.0	0.4	0.4---8.0
ED 301/6	0.6	0.7---12.0	0.4	0.4---8.0
ED 50/12	0.8	1.0---16.0	0.6	0.7---12.0
ED 80/12	0.6	0.9---12.0	0.5	0.6---10.0
ED 121/12	0.8	1.0---16.0	0.7	0.8---14.0
ED 201/12	1.0	1.3---20.0	0.5	0.6---10.0
ED 301/12	1.1	1.6---22.0	0.5	0.9---10.0

Approximate operating times and time delays (seconds) at 68° F (20° C) working oil temperatures.

By fitting the optional, externally adjustable time delays, the basic brake operating characteristics can be altered to make the brake suitable for a different set of operating conditions. On the BTE (external torque spring) the installation of the time delay (S) will enhance the smooth operation of the brake. This smooth action, with on-site adjustment capability makes this type of brake ideal for crane bridges, trolleys, conveyors, and ship loaders. This feature can also be used to provide a simple method of discriminating between the service and emergency brakes on dual drive applications.

When the time delay is installed on the release (H), the brake release can be delayed until the motor or drive has started developing torque. A typical application would be an inclined conveyor, where the brake release can be delayed to allow the motor/fluid coupling to develop forward torque, preventing the conveyor to “run-back” under the load at start-up.

### BRAKE SELECTION AND APPLICATION

Please refer to the following page for technical, dimensional information on the 300M Series—“BT” Type - 3-Phase AC Hy-Thrust Operated Brakes. If you have an unusual application or require assistance in selecting the appropriate brake, please contact Magnetek’s Application Sales Department.

## Dimensions and Ratings

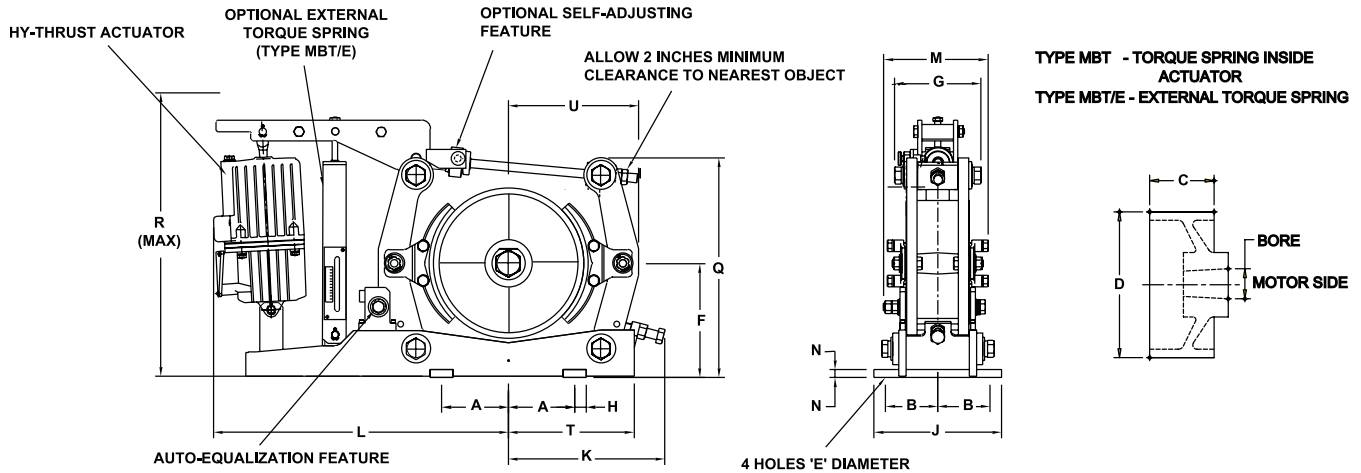

### Approximate Dimensions (Inches)

BRAKE WHEEL DIAMETER 'D'	SHOE WIDTH	A	B	C	E	F	G	H	J	K	L	M	N	Q	R	T	U
5" <sup>(2)</sup>	2.50	4.19	2.44	2.75	0.44	4.06	6.38	0.63	5.88	6.00	16.00	4.50	0.50	7.69	16.00	4.69	4.56
8"	3.00	3.25	2.88	3.25	0.69	7.00	6.38	0.75	7.25	7.25	18.00	5.38	0.75	12.63	19.13	6.88	7.00
10"	3.50	4.00	3.13	3.75	0.69	8.38	6.38	0.88	8.00	9.88	22.00	5.88	0.75	15.44	22.25	8.35	8.63
13"	5.50	5.75	4.50	5.75	0.81	9.88	7.75	1.00	11.00	12.50	24.00	8.56	0.88	19.00	24.50	10.84	11.25
16"	6.50	7.50	5.38	6.75	1.06	12.13	9.50	1.25	13.25	15.25	30.00	10.00	1.00	23.06	33.12	13.63	13.88
19"	8.50	9.25	6.50	8.75	1.06	13.25	9.50	1.75	15.63	20.25	33.00	13.00	1.13	26.25	33.50	18.50	16.63
23"	11.00	11.75	8.00	11.25	1.31	15.88	9.50	1.75	19.50	21.50	38.00	16.13	1.13	31.16	35.50	19.75	19.50
30"	14.00	15.00	9.50	14.25	1.56	20.75	9.50	2.50	23.00	27.50	44.00	20.20	1.38	40.75	44.00	26.75	25.50

For construction purposes request certified drawing.

### Rating Data AISE-NEMA and General Purpose (Heavy Duty) Fitted with Molded Non-Asbestos Linings

CATALOG		BRAKE WHEEL DIAMETER D	TORQUE RATINGS (LB.FT.) (1)		POWER INPUT (WATTS) (3)	WK <sup>2</sup> OF BRAKE WHEEL (LB.FT. <sup>2</sup> )	BRAKE WHEEL RPM (MAX)	BRAKE SHIP WEIGHT (LBS.)
TYPE BT	TYPE BT/E		AISE-NEMA	GENERAL PURPOSE				
5" BT - ED23/5C	5" BT/E - ED23/5	5"	—	50	165	0.25	9400	70
8" BT - ED23/5C	8" BT/E - ED23/5	8"	100	155	165	1.25	5870	95
10" BT - ED23/5C	10" BT/E - ED23/5	10"	200	220	165	2.80	4700	115
	- ED30/5C	10"	—	260	200	—	—	125
13" BT - ED30/5C	13" BT/E - ED30/5	13"	—	400	200	12.80	3600	200
	- ED50/6C	13"	550	550	260	—	—	235
	- ED80/6C	13"	—	660	330	—	—	240
16" BT - ED50/6C	16" BT/E - ED50/6	16"	—	500	260	29.50	2940	430
	- ED50/6C	16"	—	750	260	—	—	450
	- ED80/6C	16"	1000	1150	330	—	—	455
	- ED121/6C	16"	—	1400	330	—	—	475
19" BT - ED80/6C	19" BT/E - ED80/6	19"	—	1500	330	74.20	2470	960
	- ED121/6C	19"	—	2100	330	—	—	990
	- ED201/6C	19"	—	2650	450	—	—	990
23" BT - ED80/6C	23" BT/E - ED80/6	23"	—	1750	330	155.60	2040	1050
	- ED121/6C	23"	—	3000	330	—	—	1080
	- ED201/6C	23"	4000	4000	450	—	—	1080
	- ED301/6C	23"	—	5000	550	—	—	1080
30" BT - ED121/6C	30" BT/E - ED121/6	30"	—	3500	330	880.00	1340	1510
	- ED201/6C	30"	—	6750	450	—	—	1510
	- ED301/6C	30"	9000	11000	550	—	—	1510

RATINGS SHOWN FOR CONTINUOUS OPERATION OF ACTUATOR. THE TORQUE RATINGS APPLY AT A WORN LINING CONDITION DEFINED AS THE POINT WHERE THE BRAKE RE-ADJUSTS, OR WHERE ADJUSTMENT IS REQUIRED AS RECOMMENDED BY THE BRAKE OPERATING INSTRUCTIONS.

- (1) Service parking torque. Brake selection is based on torque and duty. When braking service is severe, the WK<sup>2</sup> of the load speed of the brake wheel and maximum number of stops per minute should be submitted to the factory for recommendation.
- (2) AISE-NEMA does not define a 5-inch size brake.
- (3) For Hy-Thrust Actuator data refer to the Application and Engineering Data section.

For selection and application data refer to the Application and Engineering Data section.

# Hi-Tork™ 300M Series

## Type “BM”—Hydraulic (Pedal) Operated Brakes

The manual pedal operated, hydraulically set—spring released shoe brakes (Type “BM”) are designed to meet the latest AISE-NEMA specifications for mill, crane and other similar heavy-duty applications. The single, rugged, wheel (slave) cylinder acts directly on the brake arms to apply variable force/torque to the brake wheel through the brake shoes. The simple design provides a long service life with a minimum of maintenance and down time.

### CONSTRUCTION

- The brake base, shoe holders and the shoes are manufactured from ductile iron.
- Fabricated steel linkages.
- The unique self-centering action compensated for a certain amount of misalignment in both the horizontal and vertical axes.
- All brake hardware is corrosion resistant.
- Composite bushings utilized in all main pivot points.
- Molded brake linings are non-asbestos and provide a constant coefficient of friction at normal operating temperatures.
- Shoe linings are bonded to the shoes delivering nearly twice the life over riveted or bolted liners.

### STANDARD FEATURES

- Manual bleeding system.
- Short pedal stroke for full braking power through the use of a dual action master cylinder.
- Maximum pedal force 70 pounds — complies with OSHA requirements.
- Brake shoes are easily replaced from either side of brake.
- Self-aligning shoes prevent wheel drag.
- Self-aligning shoes for lining wear.
- Equal shoe clearance is automatic — no adjustment is necessary.

### OPTIONAL FEATURES

- Remote control bleeding system from operator’s cab.

### DIRECT ACTING WHEEL (SLAVE) CYLINDER

This direct acting design eliminates the additional wear and maintenance associated with the long cylinder designs. The self-adjusting feature of the direct acting cylinder provides a constant, minimum shoe clearance at all times throughout the useful life of the brake shoe linings. The cylinder is mounted at the end of the brake so there is no possibility of fluid from loose fittings dripping on the brake linings or brake wheels.

### SELF-ADJUSTING

Every time the brake is applied, it adjusts itself for any wear that has taken place. When released the clearance is always the same between the brake shoe linings and the brake wheel. This feature reduces maintenance time and helps to increase productivity.

### SELF-CENTERING

The brake shoes are designed to easily pivot on the brake linkages to compensate for slight vertical centering errors between the brake and the wheel. This, along with the self-adjusting features, also allows for slight horizontal centering errors. If a brake were to shift slightly at right angles to the motor shaft or if one of the shoe liners wears more rapidly than the other, the friction bolts will slip on the base under actuating pressure, repositioning and centering the brake to the shaft/brake wheel. This self-centering feature assures longer lining life and a positive braking action.



TYPE 8" BM HYDRAULIC BRAKE

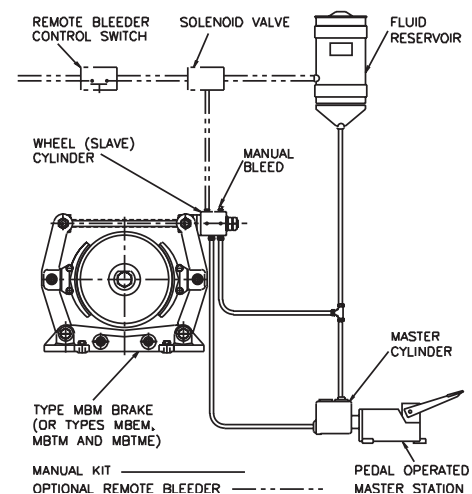

TYPICAL MANUAL HYDRAULIC BRAKE SYSTEMS ARE SHOWN IN BULLETIN MED-10

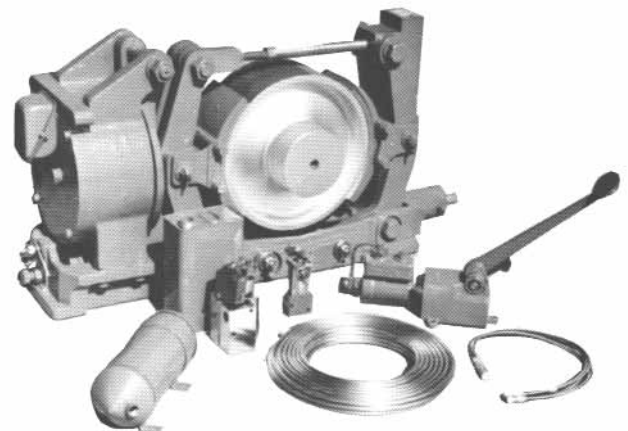

TYPE 16" BEM ELECTRIC - HYDRAULIC BRAKE AND HYDRAULIC SYSTEM COMPONENTS

## ■ BRAKE SELECTION AND APPLICATION

Please refer below for technical, dimensional information on the 300M Series — “BM” Type—Hydraulic (Pedal) Operated Brakes. If you have an unusual application or required assistance in selecting the appropriate brake, please contact Magnetek’s Application Sales Department.

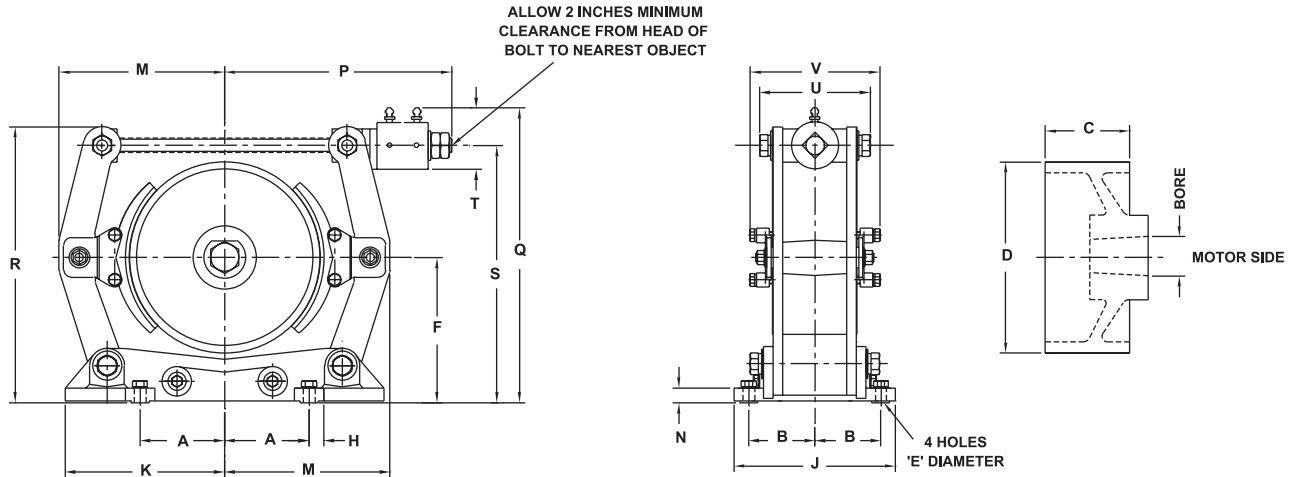

### Approximate Dimensions (inches)

CATALOG #	SHOE WIDTH	A	B	C	E	F	H	J	K	M	N	P	Q	R	S	T Dia.	U	V
5" BM(2)	2.50	4.19	2.44	2.75	0.44	4.06	0.50	5.88	4.69	4.06	0.47	8.19	9.25	7.69	7.06	2.88	4.38	4.50
8" BM	3.00	3.25	2.88	3.25	0.69	7.00	0.75	7.25	6.88	7.00	0.81	11.31	14.44	12.63	11.69	3.00	5.25	5.38
10" BM	3.50	4.00	3.13	3.75	0.69	8.38	0.88	8.00	8.35	8.63	0.94	13.00	17.06	15.44	14.31	3.00	5.63	5.88
13" BM	5.50	5.75	4.50	5.75	0.81	9.88	1.00	11.00	10.84	11.25	1.00	16.00	20.69	19.00	17.50	3.63	7.88	8.56
16" BM	6.50	7.50	5.38	6.75	1.06	12.13	1.25	13.25	13.63	13.88	1.19	17.69	24.50	23.06	21.44	3.63	8.56	10.00
19" BM	8.50	9.25	6.50	8.75	1.06	13.25	1.75	15.63	16.50	16.63	1.38	20.50	27.31	26.25	24.25	3.63	10.75	13.00

For construction purposes request certified drawing.

### Rating Data AISE-NEMA Fitted with molded non-asbestos linings

CATALOG #	BRAKE WHEEL DIAMETER D	BRAKE TORQUE (HYDRAULIC) (LB.FT.)	PEDAL FORCE (MAXIMUM) (LBS.)	WK <sup>2</sup> OF BRAKE WHEEL (LB.FT. <sup>2</sup> )	BRAKE WHEEL RPM (MAXIMUM)	BRAKE SHIP WEIGHT (LBS.)
5" BM(2)	5"	40	70	0.25	9400	45
8" BM	8"	100	70	1.25	5870	52
10" BM	10"	200	70	2.80	4700	83
13" BM	13"	550	70	12.00	3600	180
16" BM	16"	1000	70	29.50	2940	305
19" BM	19"	2000	70	74.20	2470	458

(1) Brake selection should be based on torque and duty. When braking service is severe, the WK<sup>2</sup> of the load speed of the brake wheel and maximum number of stops per minute should be submitted to the factory for recommendation.

(2) AISE-NEMA does not define a 5-inch brake.

For selection and application data refer to the Application and Engineering Data section.

# Hi-Tork™ 300M Series

## Type “BEM”—DC Magnetic-Hydraulic Operated Shoe Brakes

The DC Magnet Operated Brakes (Type BE) can be fitted with a pedal operated (manual) hydraulic over-ride system. The brake designation then becomes a BEM Type. This type of brake combines a hydraulic set/spring release brake with a spring set/magnetically released brake. The BEM Type shoe brake includes all the features of the individual BE Type DC magnet operated brakes and the BM Type hydraulic (pedal) operated brakes. This hybrid brake complies with all of the relevant AISE-NEMA ratings and will provide a long service life with a minimum of downtime and maintenance.

### CONSTRUCTION

- The brake base, shoe holders and the shoes are manufactured from ductile iron.
- Fabricated steel linkages
- The magnet case and armature are made of cast steel.
- All brake hardware is corrosion resistant.
- Composite bushings utilized in all main pivot points.
- The “floating-linkages” provide positive braking action with equal lining wear.
- Molded brake linings are non-asbestos and provide a constant coefficient of friction at normal operating temperatures.
- Shoe linings are bonded to the shoes delivering nearly twice the life over riveted or bolted liners.

### STANDARD FEATURES

- Self adjustment of the hydraulic wheel (slave) cylinder to compensate for lining wear.
- Top-hinged magnet prevents dirt and debris from building up between the magnet case and the armature.
- Anti-friction composite bushings utilized in all main pivot points for improved impact resistance.
- Class “F” insulation
- Easily replaceable magnet coil—may be replaced without the loss of brake torque.
- Watertight coil and terminal box
- Self-aligning brake shoes—prevents wheel drag
- Emergency brake release
- Floor mounting
- Short pedal stroke for full braking power through the use of a dual action master cylinder
- Equal shoe clearance is automatic—no adjustment necessary

### OPTIONAL FEATURES

- Class “H” insulation
- Patented Self-Adjustment for lining wear maintains shoe clearance while minimizing impact loading of pivot points.
- Manual latching brake release lever
- Armature position indicator switch
- Wall and ceiling mounting configurations (Consult Factory)
- Remote control bleeding system from operator’s cab



TYPE 10" BEM ELECTRIC-HYDRAULIC BRAKE

### OPERATION

During normal operation, the continuously rated magnet coil is energized, and the brake is electrically released. Shutting down the power to the brake will de-energize the magnet coil allowing the torque spring to set the brake.

The hydraulic portion of the brake functions in the same manner and uses the same components as the BM type brakes described on page 13. With the magnet energized, a pedal operated master cylinder assembly mounted in the operator’s area, controls brake application. This arrangement provides the operator with a smooth method of slowing and stopping the crane. The amount of braking force is proportional to the amount of force applied to the master cylinder foot pedal.

The single acting cylinder acts directly to pull the links/brake shoes together. The design eliminates the additional links, pins and extra wear points along with the maintenance associated with these items. The cylinder is mounted below and off to one side of the brake so there is no possibility of fluid from loose fittings dripping onto the brake shoe linings or brake wheels.

**Note:** When considering this type of brake for AC supplies, especially dual control, CAB/RADIO and CAB/PENDANT applications, consideration should be given to the advantages of the type BTM Hy-Thrust Brakes on pages 19-21. The Hy-Thrust Actuator can be fitted with an externally adjustable time delay on the setting stroke. This important feature, combined with adjustment of the brake torque, permits simple, on-site fine-tuning of the brake to minimize load swing. This arrangement has proved to be a simple, low-cost alternative to the complicated and expensive air/hydraulic or powered hydraulic systems commonly used on radio or dual controlled cranes.

## VOLTAGES

Continuously rated, shunt wound coils are available for a variety of voltages (Contact Factory for details). The shunt wound brake is designed to release on 80% of voltage. The AISE-NEMA torque ratings are obtained with a continuous duty coil at intermittent duty torque ratings. Other shunt coils are available for use with AC static rectifier control.

## AC STATIC RECTIFIER OPERATION

On AC powered equipment where customers prefer a DC brake, an AC/DC controller can be provided. This unit includes a transformer, rectifier, brake contactor, protective fusing and a static brake control timer board. The standard controller is mounted in a NEMA 3R Enclosure or on a panel for mounting inside customers' equipment. Standard units are suitable for 230/460/575-3Ph-60Hz power supplies (voltage to be specified at time of order). For special voltages, frequencies or other applications, please contact factory.

## PATENTED SELF-ADJUSTMENT FEATURE

You never need to adjust this brake for lining wear! It adjusts itself, no troublesome mechanical linkages, star wheels or other devices for brake adjustment are required. The simple, automatic, dependable way in which the adjustment is accomplished is explained in the illustration below.

Each time the brake is released, the *end stop*, attached to the *brake rod*, moves slightly to the right through the *pivot block*, *adjusting plates* and *plate enclosure*. If the brake linings have worn enough so that adjustment is required, the *end stop* will move far enough so that an *adjusting plate* can drop from its upper position to its lower position around the *brake rod*. Since this *adjusting plate* is now between the *end stop* and *pivot block*, it shortens the effective travel of the *brake rod* on the application so that the brake is again in correct adjustment.

In this way, the brakes self-adjust throughout the full thickness of the linings or until linings are replaced. This feature delivers increased productivity and decreased maintenance time. It also protects the entire brake assembly from the impact loads that can become excessive as the gap between the shoes and the wheel increases.

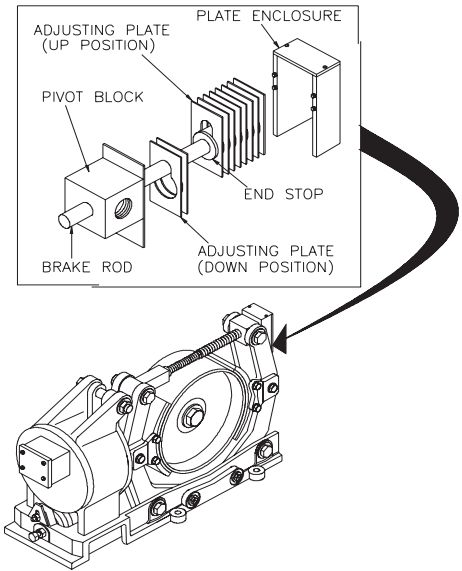

## BRAKE SELECTION AND APPLICATION

Please refer to the following page for technical, dimensional information on the 300M Series "BEM"—DC Magnetic-Hydraulic Operated Brakes. If you have an unusual application or require assistance in selecting the appropriate brake, please contact Magnetek's Application Sales Department.

# Hi-Tork™ 300M Series

## Type “BEM”–DC Magnetic-Hydraulic Operated Shoe Brakes

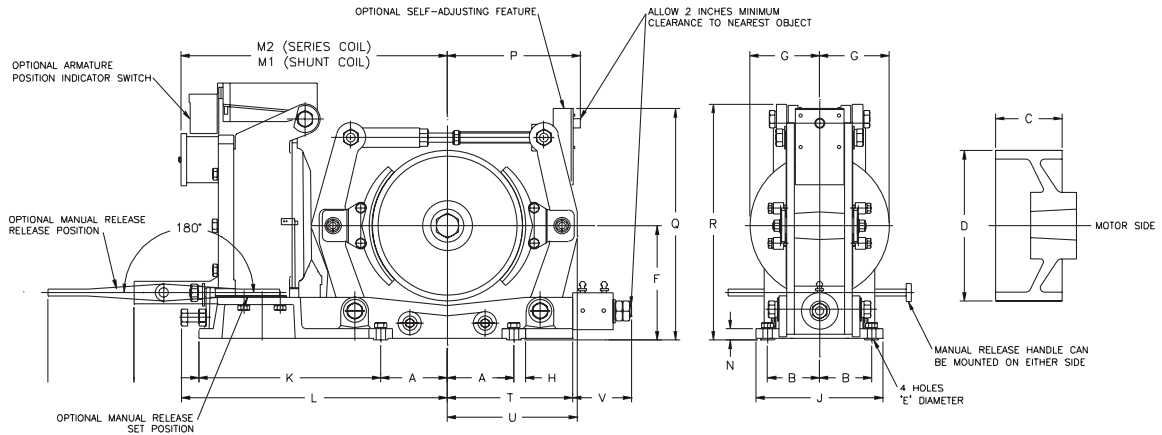

### Approximate Dimensions in Inches

CATALOG #	SHOE WIDTH	A	B	C	D	E	F	G	H	J	K	L	M1	M2	N	P	Q	R	T	U	V
5" BEM	2.50	4.19	2.44	2.75	5.00	0.44	4.06	3.50	0.50	5.88	7.44	12.88	13.38	—	0.47	9.03	8.59	9.59	4.69	4.56	4.00
8" BEM	3.00	3.25	2.88	3.25	8.00	0.69	7.00	4.00	0.75	7.25	12.25	17.44	17.69	17.69	0.81	7.56	13.31	13.13	6.88	7.00	5.81
10" BEM	3.50	4.00	3.13	3.75	10.00	0.69	8.38	4.84	0.88	8.00	13.97	19.81	19.38	19.81	0.94	9.38	16.38	16.19	8.35	8.63	6.65
13" BEM	5.50	5.75	4.50	5.75	13.00	0.81	9.88	6.28	1.00	11.00	15.69	23.90	23.00	25.00	1.00	11.50	20.00	20.38	10.84	11.25	7.69
16" BEM	6.50	7.50	5.38	6.75	16.00	1.06	12.13	7.09	1.25	13.25	18.81	28.16	27.19	29.31	1.19	15.00	24.47	24.00	13.63	13.88	7.69
19" BEM	8.50	9.25	6.50	8.75	19.00	1.06	13.25	8.69	1.75	15.63	22.31	33.25	32.00	34.00	1.38	17.63	28.25	27.63	16.50	16.63	8.18

For construction purposes request certified drawing.

### Rating Data AISE-NEMA Fitted with Molded Non-Asbestos Linings

CATALOG #	BRAKE WHEEL DIAMETER D	TORQUE RATING (LB.FT.) (1)								WK <sup>2</sup> OF BRAKE WHEEL (LB.FT. <sup>2</sup> )	BRAKE WHEEL RPM (MAX)	BRAKE SHIP WEIGHT (LBS.)
		SHUNT				RECTIFIER OPERATED						
		CONTINUOUS (8-HOUR) DUTY		8-HOUR (100% DUTY) HI-SPEED FORCED		8-HOUR (100% DUTY CYCLE) (2)		8-HOUR (100% DUTY) HI-SPEED FORCED (2)				
		SPRING	HYD	SPRING	HYD	SPRING	HYD	SPRING	HYD			
5" BEM (3)	5"	30	40	40	40	30	40	40	40	0.25	9400	113
8" BEM	8"	75	100	100	100	75	100	100	100	1.25	5870	150
10" BEM	10"	150	200	200	200	150	200	200	200	2.8	4700	224
13" BEM	13"	400	550	550	550	400	550	550	550	12	3600	438
16" BEM	16"	750	1000	1000	1000	750	1000	1000	1000	29.5	2940	715
19" BEM	19"	1500	2000	2000	2000	1500	2000	2000	2000	74.2	2470	1195

### Rating Data for General Purpose (Heavy Duty) Fitted with Molded Non-Asbestos Linings

5" BEM	5"	40	40	40	40	40	40	40	40	0.25	9400	113
8" BEM	8"	100	120	100	100	100	120	100	100	1.25	5870	150
10" BEM	10"	200	240	200	200	200	240	200	200	2.8	4700	224
13" BEM	13"	550	660	550	550	550	660	550	550	12	3600	438
16" BEM	16"	1000	1200	1000	1000	1000	1200	1000	1000	29.5	2940	715
19" BEM	19"	2000	2650	2000	2000	2000	2650	2000	2000	74.2	2470	1195

RATINGS SHOWN FOR 8-HOUR ARE THE THERMAL RATINGS OF THE COIL.

THE TORQUE RATINGS APPLY AT A WORN LINING CONDITION DEFINED AS THE POINT WHERE THE BRAKE RE-ADJUSTS, OR WHERE ADJUSTMENT IS REQUIRED AS RECOMMENDED BY THE BRAKE OPERATING INSTRUCTIONS.

- (1) Service or parking torque. Brake selection is based on torque and duty. When braking service is severe, the WK<sup>2</sup> of the load speed of the brake wheel and maximum number of stops per minute should be submitted to the factory for recommendation.
- (2) Rectifier operated brakes are used with an AC power source and are provided with DC shunt release coils. Maximum 7 ½ operations per minute.
- (3) AISE-NEMA does not define a 5-inch brake.



# Hi-Tork™ 300M Series

## Types “BTM” & “BTME”–Hydraulic 3-Phase AC Hy-Thrust Operated Brakes

The BT (and BTE) type, 3-phase AC shoe brakes described on page 10 can be fitted with a pedal operated (manual) hydraulic override system. This type of brake combines a hydraulic set/spring release brake with a spring set/electrically released brake. These brakes retain all of the features and characteristics of the individual type BT and BTE 3-phase AC Hy-Thrust Operated brakes and BM Hydraulic brakes. This hybrid brake complies with all of the relevant AISE-NEMA ratings and will provide a long service life with minimal downtime and maintenance.

### OPERATION

During normal operation the continuously rated Hy-Thrust Actuator is energized and the brake is electrically released. Shutting down the power to the brake will de-energize the actuator allowing the torque spring to set the brake. A stop button located in the cab can be used to de-energize the brake to provide an emergency stop function should the hydraulic system fail.

The operator can apply torque to the brake wheel through the hydraulic foot pedal, over-riding the electrically released actuator. The amount of braking force/torque is proportional to the amount of force applied to the foot pedal.

The hydraulic force created is transmitted to the double acting wheel (slave) cylinder, which acts directly on the brake links/brake shoes forcing them together. This brake combination provides the operator with a smooth method of slowing and stopping hydraulically, plus an emergency stopping and parking brake.

When fitted with the adjustable time delay on the setting stroke, the external torque spring and the manual pedal operated over-ride provides a simple, effective and inexpensive alternative to the air/hydraulic or powered hydraulic systems commonly used for dual controlled Cab/ Radio or Cab/ Pendant cranes.

### STANDARD FEATURES

- Internal torque springs–Type BTM
- Main pivot points are fitted with anti-friction composite bushings.
- Replaceable, waterproof Hy-Thrust Actuator
- Brake shoes are self-aligning.
- Convenient manual adjustment for lining wear
- Manual release lever
- Floor mounting

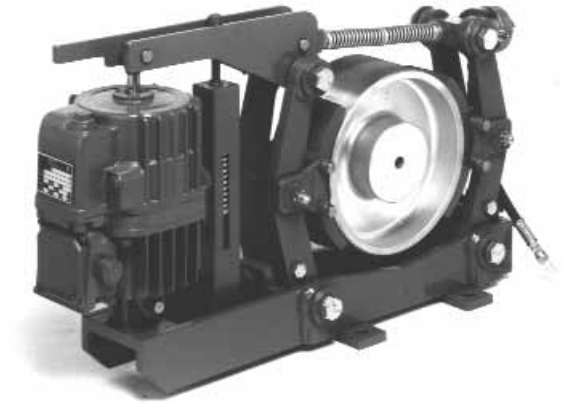

TYPE 10" BTME-Ed/5S AC HY-THRUST BRAKE

### OPTIONAL FEATURES

- External torque springs–Type BTME
- Time delays on brake setting ("S") and release ("H")
- Self-adjustment for lining wear
- Hydraulic pedal operated manual over-ride systems
- Power assist hydraulic over-ride

### TORQUE ADJUSTMENT OPTIONS

The standard Type "BTM" (Internal torque spring):

- Torque spring compression rating is fixed within the thruster.
- Pre-set torque setting provided by pull rod pivot pin locations (4).
- Torque may be reduced to 60% of maximum rating - (Consult factory for additional information)

The optional Type "BTME" (External torque spring):

- Provides stepless torque adjustment
- Torque adjustment made by rotating the nut atop the spring tube assembly.
- Torque may be reduced to 40% of maximum rating.
- The actual setting can be read on the calibrated torque indicator (C.T.I.) located in the side of the spring tube assembly.

### SELF-ADJUSTING FOR LINING WEAR

Both the "BTM" and the "BTME" type actuator brakes can be fitted with an optional device which automatically compensates for lining wear throughout the full thickness life of the linings. The self-adjusting feature consists of a one-way operating clutch, mounted on a special pull-rod, which replaces the standard pull-rod assembly. As the brake linings wear, the actuator stroke increases. This increased movement will cause a small pin mounted on the brake linkages to rotate the clutch / pull-rod assembly a few degrees. This rotation draws the brake arms slightly closer together, compensating for the wear in the brake shoe linings. The optional self-adjusting feature eliminates the time required to manually adjust the linkages for brake shoe lining wear. It does not reduce or eliminate the planned maintenance inspections as recommended in the Operation and Maintenance manual provided with the brake.

# Hi-Tork™ 300M Series

## Types “BTM” & “BTME”–Hydraulic 3-Phase AC Hy-Thrust Operated Brakes

The Hy-Thrust electro-hydraulic actuators are proven, high performance, reliable units that will provide years of trouble free service in tough operating conditions. The major components of the actuator are a 3-phase motor, centrifugal pump and a servo-cylinder with a piston. Various types of fluids provide the operating medium and all the units are filled with the appropriate fluid at the factory. The impellor runs freely inside the cylinder and even if the piston rod is not allowed to complete its stroke, the motor is not subject to an overload condition.

### STANDARD FEATURES

- Fast response times
- High switching frequency–1200 to 2000 operations per hour
- Long service life–20 million switching cycles
- Working fluid operating range -13° F (-25° C) through 122° F (50° C.)
- Built in compression spring (Standard "BT" Type)
- Available for 230VAC, 460VAC, 575VAC/3ph/60Hz as standard

### OPTIONAL FEATURES

- Stepless, externally adjustable time delays, Setting ("S"), Releasing ("H"), or Both ("HS")
- Special fluids for operating in extreme ambient temperatures
- External torque springs ("BTE" Type)
- Encapsulated motor stator
- Corrosion protection
- Stator completely encapsulated into motor housing under vacuum
- Explosion-proof and flame-proof units

### ELECTRICAL DESIGN

#### Motor

- 2-pole, 3-phase AC squirrel cage
- Class “F” insulation standard (Class “H” optional)
- Continuous rating
- Integral terminal box with gasketed cover plate (IP 65)
- Terminal block 6-pole
- Cable entry NPT

#### Power Supply

- 230VAC, 460VAC, 575VAC/3ph/60Hz standard
- All units connected in Star (Y) configuration
- Special voltages and frequencies available
- DC Voltage actuators are available (Contact Factory)
- Single-phase actuators are not available

### MOTOR OPERATING CURRENTS (68° F/20° C)

Thruster	230/3/60 Volts	460/3/60 Volts	575/3/60 Volts
ED 23	0.88 Amps	0.44 Amps	0.38 Amps
ED 30	0.76	0.38	0.33
ED 50	0.86	0.43	0.37
ED 80	2.2	1.1	0.96
ED 121	2.2	1.1	0.96
ED 201	2.4	1.2	1.2
ED 301	2.6	1.3	1.1
ED 185	2.4	1.2	1.0

### WORKING FLUID

#### Standard

- Shell Morlina C10
- Ambient operating temperature range -13° F (-25° C) through 122° F (50° C)

#### Optional

- Baysilone M20
- Ambient operating temperature range -40° F (-40° C) through 176° F (80° C)

### TIME DELAYS ON BRAKE SETTING AND RELEASE

Catalog #	Time to Extend (Sec)		Time to Retract (Sec)	
	Without Valve	With Valve	Without Valve	With Valve
ED 23/5	0.4	0.7–6.0	0.4	0.6–6.0
ED 30/5	0.4	0.5–8.0	0.4	0.5–8.0
ED 50/6	0.5	0.7–10.0	0.4	0.5–8.0
ED 80/6	0.4	0.5–8.0	0.4	0.4–8.0
ED 121/6	0.4	0.5–8.0	0.5	0.5–10.0
ED 201/6	0.5	0.7–10.0	0.4	0.4–8.0
ED 301/6	0.6	0.7–12.0	0.4	0.4–8.0
ED 50/12	0.8	1.0–16.0	0.6	0.7–12.0
ED 80/12	0.6	0.9–12.0	0.5	0.6–10.0
ED 121/12	0.8	1.0–16.0	0.7	0.8–14.0
ED 201/12	1.0	1.3–20.0	0.5	0.6–10.0
ED 301/12	1.1	1.6–22.0	0.5	0.9–10.0

Approximate operating times and time delays (seconds) at 68° F (20° C) working oil temperatures.

By fitting the optional, externally adjustable time delays, the basic brake operating characteristics can be altered to make the brake suitable for a different set of operating conditions. On the BTE (external torque spring) the installation of the time delay (S) will enhance the smooth operation of the brake. This smooth action, with on-site adjustment capability, makes this type of brake ideal for crane bridges, trolleys, conveyors, and ship loaders. This feature can also be used to provide a simple method of discriminating between the service and emergency brakes on dual drive applications.

When the time delay is installed on the release (H), the brake release can be delayed until the motor or drive has started developing torque. A typical application would be an inclined conveyor, where the brake release can be delayed to allow the motor/fluid coupling to develop forward torque, preventing conveyor "run-back" under load at start-up.

### BRAKE SELECTION AND APPLICATION

Please refer to the following page for technical, dimensional information on the 300M Series–"BT" Type–3-Phase AC Hy-Thrust Operated Brakes. If you have an unusual application or require assistance in selecting the appropriate brake please contact Magnetek's Application Sales Department.

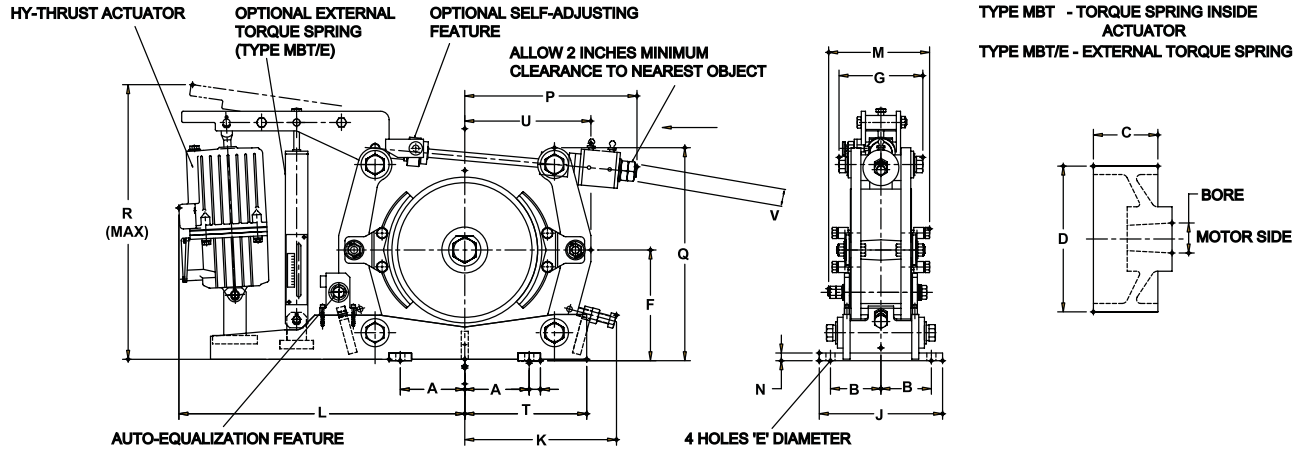

**Approximate Dimensions in Inches**

BRAKE WHEEL DIAMETER 'D'	SHOE WIDTH	A	B	C	E	F	G	H	J	K	L	M	N	P	Q	R	T	U	V
5" (2)	2.50	4.19	2.44	2.75	0.44	4.06	6.38	0.63	5.88	6.00	16.00	4.50	0.50	8.19	7.69	15.50	4.69	4.56	2.88
8"	3.00	3.25	2.88	3.25	0.69	7.00	6.38	0.75	7.25	7.25	18.00	5.38	0.75	11.31	12.63	15.50	6.88	7.00	3.00
10"	3.50	4.00	3.13	3.75	0.69	8.38	6.38	0.88	8.00	9.88	22.00	5.88	0.75	13.00	15.44	19.13	8.35	8.63	3.00
13"	5.50	5.75	4.50	5.75	0.81	9.88	7.75	1.00	11.00	12.50	24.00	8.56	0.88	16.00	19.00	23.13	10.84	11.25	3.63
16"	6.50	7.50	5.38	6.75	1.06	12.13	9.50	1.25	13.25	15.25	30.00	10.00	1.00	17.69	23.06	31.75	13.63	13.88	3.63
19"	8.50	9.25	6.50	8.75	1.06	13.25	9.50	1.75	15.63	20.25	33.00	13.00	1.13	20.50	26.25	33.00	18.50	16.63	3.63

**Ratings Data AISE-NEMA and General Purpose (Heavy Duty)** Fitted with molded non-asbestos linings

CATALOG		BRAKE WHEEL DIAMETER D	TORQUE RATINGS (LB.FT.) (1)		POWER INPUT (WATTS) (3)	WK <sup>2</sup> OF BRAKE WHEEL (LB.FT. <sup>2</sup> )	BRAKE WHEEL RPM (MAX)	BRAKE SHIP WEIGHT (LBS.)
TYPE BTM	TYPE BTM/E		AISE-NEMA	GENERAL PURPOSE				
5" BTM - ED23/5C	5" BTM/E - ED23/5	5"	-	50	165	0.25	9400	70
8" BTM - ED23/5C	8" BTM/E - ED23/5	8"	100	155	165	1.25	5870	95
10" BTM - ED23/5C	10" BTM/E - ED23/5	10"	200	220	165	2.80	4700	115
- ED30/5C	- ED30/5	10"	-	260	200	-	-	125
13" BTM - ED30/5C	13" BTM/E - ED30/5	13"	-	400	200	12.0	3600	200
- ED50/6C	- ED50/6	13"	550	550	260	-	-	235
- ED80/6C	- ED80/6	13"	-	660	330	-	-	240
16" BTM - ED50/6C	16" BTM/E - ED50/6	16"	-	500	260	29.5	2940	430
- ED50/6C	- ED50/6	16"	-	750	260	-	-	450
- ED80/6C	- ED80/6	16"	1000	1150	330	-	-	455
- ED121/6C	- ED121/6	16"	-	1400	330	-	-	475
19" BTM - ED80/6C	19" BTM/E - ED80/6	19"	-	1500	330	74.2	2470	960
- ED121/6C	- ED121/6	19"	2000	2100	330	-	-	990
- ED201/6C	- ED201/6	19"	-	2650	450	-	-	990

RATINGS SHOWN FOR CONTINUOUS OPERATION OF ACTUATOR

THE TORQUE RATINGS APPLY AT A WORN LINING CONDITION DEFINED AS THE POINT WHERE THE BRAKE RE-ADJUSTS, OR WHERE ADJUSTMENT IS REQUIRED AS RECOMMENDED BY THE BRAKE OPERATING INSTRUCTIONS.

- (1) Service or parking torque. Brake selection is based on torque and duty. When braking service is severe, the WK<sup>2</sup> of the load speed of the brake wheel and maximum number of stops per minute should be submitted to the factory for recommendation.
- (2) AISE-NEMA does not define a 5-inch size brake.

# Hi-Tork™ 300M Series

## Manual Hydraulic Brake System Kits for Brake Types “BM”, “BEM”, “BTM” & “BTME”

The 300M Pedal Controlled Manual Hydraulic Brake Systems are designed for the BM Type Hydraulic Brake, the BEM Type DC Magnet Operated Brake and the BTM/BTME Type 3-phase AC Thruster Operated Brake models. In all cases, the hydraulic portion functions in the same manner and utilizes the same basic components. The system provides crane operators with a smooth method of slowing and stopping the crane bridge.

The following is a list of the manual systems available:

- Single brake, single station, with manual bleed
- Single brake, single station, with remote bleed
- Dual brake, single station, with manual bleed
- Dual brake, two station, with remote bleed
- Single brake, two station, with remote bleed
- Dual brake, two station, with remote bleed

Each brake kit contains all the components, tubing and miscellaneous hardware required to complete a normal installation. The Manual Hydraulic Brake System Kit must be ordered individually; they are not included with the brake assemblies and wheel (slave) cylinders.

### OPERATION

Mechanical force applied to the foot pedal is converted to hydraulic pressure by the master cylinder. This hydraulic pressure is transmitted via the connecting lines to the brake wheel (slave) cylinder, which in turn operates the brake. The pressure developed by the master cylinder is proportional to the force applied to the foot pedal. Thus the pedal/master cylinder assembly provides a control that is infinitely variable between zero and the maximum force/torque rating.

A provision is made in all systems to keep the back end of the wheel (slave) cylinders filled with fluid. The line for this purpose connects to a “tee” in the line leading from the reservoir to the master cylinder. Keeping the back end of the wheel (slave) cylinders filled with fluid provides lubrication for the piston, reduces contamination and prevents air from being drawn past the piston.

### FEATURES

- Short brake pedal for full braking power through the use of a dual action master cylinder
- Maximum of 70 pounds of pedal force (Complies with OSHA requirements)
- Standard manual system can operate up to 2–16" brakes or 1–19" brake

### NOTES

- The maximum line length from master cylinder to the wheel (slave) cylinder should not exceed 150 feet (length of pressurized system tubing—one way). In a dual brake/one station system, the line length from the master cylinder to each wheel (slave) is limited to 150 feet.
- The wheel cylinder and the master cylinder must be compatible with respect to the type of brake fluid that each system uses.

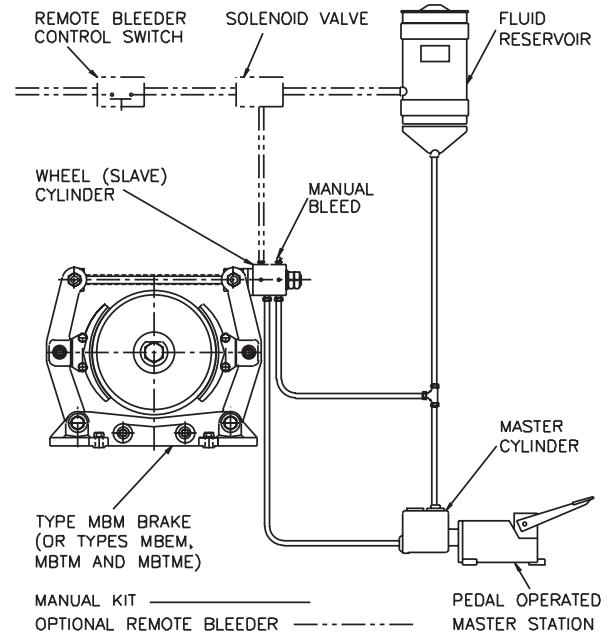

TYPICAL MANUAL HYDRAULIC BRAKE SYSTEMS

The manual system illustrated above shows a single brake, one-station arrangement with the standard manual bleed. The optional remote control bleed is shown dotted.

The remote control bleed system permits quick and easy bleeding of the system by the crane operator from the cab. The system consists of a fluid reservoir, a solenoid-operated control valve and a pushbutton switch which operates the valve. The pushbutton switch should be installed in a location convenient to the crane operator.

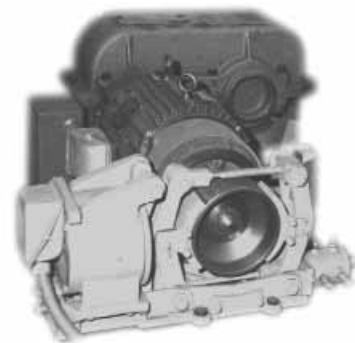

TYPE 10" BEM ELECTRIC-HYDRAULIC BRAKE

# Hi-Tork™ 300M Series

## Manual Hydraulic Brake Systems

### HYDRAULIC BRAKE KITS — ALL SIZES

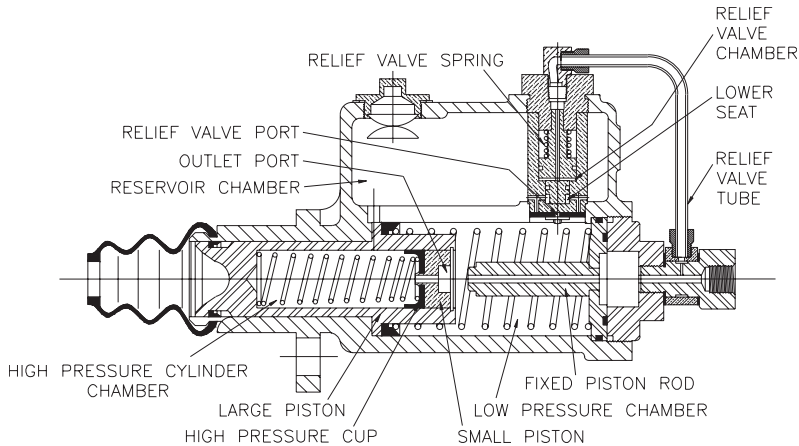

FIG. 2 MASTER CYLINDER ASSEMBLY

The complete master cylinder assembly, as shown in Fig. 3 consists of: the master cylinder, a foot pedal, a mounting base and the operating linkage.

The master cylinder is a two-stage unit, containing one large diameter piston and one smaller diameter piston (Reference Fig. 2). The large diameter piston displaces a substantial volume of fluid with a relatively small amount of foot pedal travel. This volume of fluid is forced out through the passage in the fixed piston rod to the wheel cylinder and quickly moves the brake shoes into contact with the brake wheel. Resistance to further movement of the shoe causes pressure to build in the system. This pressure is sensed in the metered relief valve. At a predetermined pressure level, the relief valve lifts off its lower seat, venting the lower pressure chamber into the reservoir chamber. High pressure exists in the high pressure cylinder chamber and the low pressure cup flares out and seals against the walls of the high pressure cylinder chamber.

The small piston is now up against the end of the fixed piston rod, and continued movement of the large piston effectively shortens the length in height of the high-pressure cylinder chamber. The pressure in this chamber increases as the chamber volume decreases and is transmitted through the fixed piston rod passage and out to the brake wheel cylinder. Due to the smaller area on the piston, pressure developed with a given amount of foot pedal force is much greater than pressure developed by the large piston. In summary, the large diameter piston serves to move the brake shoes rapidly into contact with the brake wheel while using up little of the total pedal travel. The small piston serves to develop high pressure for positive braking.

#### MANUAL KIT

Includes:

- Foot operated master station
- Reservoir
- Fittings
- Flexible hose
- Hydraulic fluid
- Copper tubing
  - Single—100 ft.
  - Duplex—200 ft.
  - Quadruplex—250 ft.
- (Manual #560041)

#### REMOTE BLEEDER

Includes:

- Bleeder-reservoir assembly
- Copper tubing—100 ft.
- Fittings
- Single element pushbutton

**Note:** The above kit is required for **each** brake in the system.

(Manual #560041)

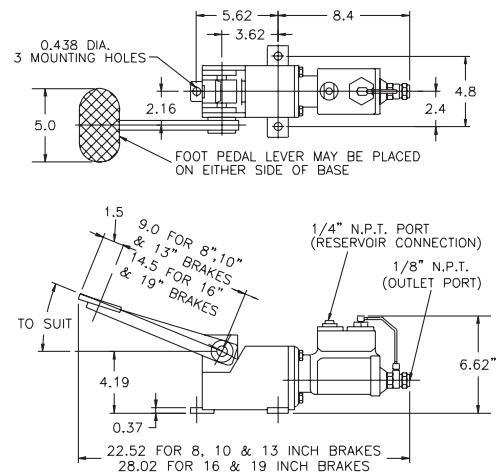

FIG. 3 PEDAL/MASTER CYLINDER DIMENSIONS

# Hi-Tork™ 300M Series

## Type "ABW" – Brake Wheels

The ABW Type Brake Wheels are manufactured from specially formulated ductile-iron alloy castings. This material has great strength, good machinability and is resistant to scoring. It is compatible with a variety of friction materials, where as the lining and the brake wheel wear evenly and smoothly. Fully machined wheels can be supplied with a parallel or tapered bore and keyway to meet the customer's specifications. Tapered bored hubs can be provided with a bent lock washer slot to give a more positive method of locking the wheel to the shaft. The wheels can be furnished completely machined to provide proper balance at normal operating speeds. Brake wheels can also be furnished semi-finished with a solid or rough bored hub for final machining by the customer. Standard wheel dimensions are shown on the table below; wheels that do not fall within these dimensional parameters may still be available, please contact the factory.

### STANDARD FEATURES

- Manufactured from ductile-iron alloy
- Completely machined to provide proper balance at normal operating speeds.
- Resistant to scoring
- Wears smoothly and evenly
- Good compatibility with friction materials

### OPTIONAL FEATURES

- Parallel bore and keyway
- Tapered bore and keyway
- Lock washer slot
- Special materials, tool steel, etc.
- Deep carburizing
- Chrome plated brake path
- Dynamic balancing
- Non-destructive testing
- Brake wheel couplings

### SELECTING BRAKE WHEEL HUB OFFSET

1. Start from the wheel centerline and determine offset dimension "O" within the maximum and minimum dimensions provided in table below.
2. Determine hub length, dimension "E" required.
3. Use the following formula to see if dimension "F" value falls within the limits provided in the table below.  

$$"X" = "E" - "O"$$

$$"F" = (1/2"C") - "X"$$
4. If the "F" dimension does not fall within the limits provided in the table, change dimension "O" within limits provided in the table.
5. Wheels that do not fall within the limits provided in the table below must be checked with the factory for cost and availability. Note that more than one wheel pattern is available.

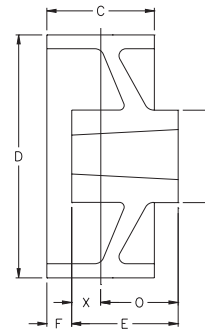

### BORE AND KEYWAY MACHINING

- For machining wheel bores and keyways, please provide complete shaft dimensional data.
- For tapered shafts, don't forget the "taper per foot" data
- For parallel bores provide complete keyway dimensions and advise if gib key or keeper plate will be used to hold the wheel to the shaft.
- For standard AISE-NEMA DC or AC wound rotor motors, only the motor information is required.
- For non-standard motors and special wheels, please contact factory.

### Rating Data and Approximate Dimensions /Weights

WHEEL DIAMETER IN.	WHEEL WIDTH 'C' IN.	HUB DIAMETER 'S' IN.	'O' OFFSET		'F'		MAX BORE RECOMMENDED IN.	MAX SPEED R.P.M.	WK <sup>2</sup> (APPROX) LB.FT. <sup>2</sup>	WEIGHT (APPROX) LBS.
			MAX IN.	MIN IN.	MAX IN.	MIN IN.				
5" (1)	2.75	3.13	3.00	1.37	1.37	0.812	2.00	9400	0.25	7
8"	3.25	3.75	4.88	2.00	2.37	1.12	2.00	5870	1.25	20
10"	3.75	4.75	5.00	2.75	2.62	1.87	2.50	4700	2.80	34
13"	5.75	6.75	6.25	3.12	4.25	1.62	4.75	3600	12.00	75
16"	6.75	6.75	6.50	3.37	5.00	2.62	4.00	2940	29.50	115
19"	8.75	7.00	7.50	5.50	7.50	5.62	4.62	2470	74.20	180
23"	11.25	9.50	8.88	5.25	7.88	5.50	5.00	2040	155.60	305
30"	14.25	13.50	12.75	9.50	12.75	7.13	7.00	1340	880.00	980

(1) AISE-NEMA does not define a 5" Brake.

For construction purposes request certified drawing.

# Hi-Tork™ 300M Series Brake Wheel Couplings

## ■ BRAKE WHEEL COUPLINGS

The brake wheel couplings are available for all 300M Series shoe brakes. They are useful in situations where space is limited and also eliminate the need for expensive double shaft extensions on motors and gearboxes.

## ■ SELECTION

- Torque ratings listed are typical values for the 300M Series brakes based on normal operation of the drive systems. For repetitive high peak load applications please contact the factory.
- Maximum speeds (RPM) are based on the maximum RIM velocity of 6000 feet per minute. Brake wheels and couplings must be balanced if peripheral speeds exceed this value.
- Couplings are normally furnished with an average interference fit of 0.0005" per inch of shaft diameter, unless otherwise specified.
- The high centrifugal forces encountered in couplings separate the base oil and thickener of general-purpose greases. Special coupling grease only should be used.
- Standard coupling seals are BUNA-N material. Maximum continuous operating temperature is 250° F (121° C) and maximum intermittent (less than 1000 hours) operating temperature is 300° F (149° C).
- For unlisted brake torques and coupling types, please consult the factory.
- Metric sizes are optional.

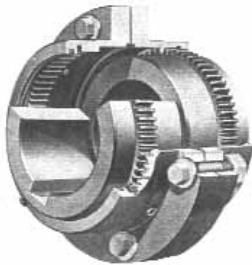

TYPE G62 GEARED COUPLINGS

## ■ BRAKE WHEEL COUPLING ORDERING INFORMATION

- 1) Specify coupling (If selecting from the standard units shown on pg. 26 simply specify the catalog number. Example 13" x 5.75" - 1025G) or if not known please supply the following information:
  - Brake wheel diameter and face width
  - Motor HP and RPM (or speed) of shaft that the brake wheel is to be mounted
  - Gear ratio or shaft speeds
  - Details of the application
- 2) Specify hub bores and keyway dimensions

### STRAIGHT SHAFTS:

	Driving Shaft	Driven Shaft
Shaft Diameter (provide tolerance)	U=	U=
Keyway Width	M=	M=
Keyway Depth	N=	N=

### TAPER SHAFTS:

Shaft Diameter (provide tolerance)	U=
Length Dim	V=
Length Dim	W=
Length Dim	X=
Length Dim	Y=
Across flats	=
Across corners	ZW=
Taper (1.25 per foot or other)	=
Keyway width	M=
Depth	N=

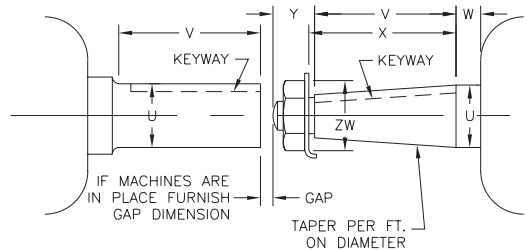
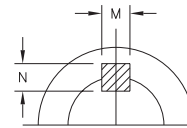

# Hi-Tork™ 300M Series Brake Wheel Couplings

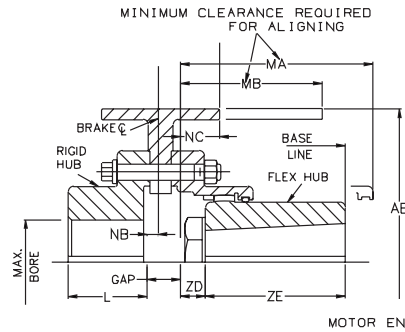

FIG. 1

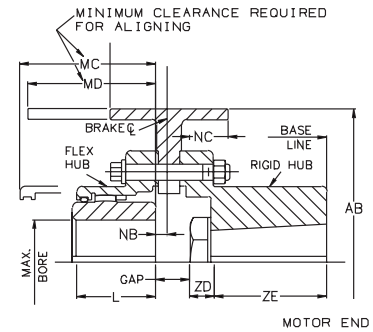

FIG. 2

## Approximate Dimensions (inches)

BRAKE WHEEL AB x JB	COUPLING REF	C	L	M	MA MB MAX	MC MD MAX	NB FIG 2	NB FIG 1	NC	ZD	ZE	GAP
CATALOG #												FIG 1 & 2
8 X 3.25 - 1015G		1.94	1.82	2.40	4.50	2.90	0.56	0.61	1.47	0.94	3.00	0.660
10 X 3.75 - 1015G		1.94	1.82	2.40	5.00	2.90	0.88	0.92	2.03	1.00	3.50	0.660
13 X 5.75 - 1020G		2.44	2.30	3.00	5.62	3.50	0.75	0.80	2.91	1.13	4.00	0.660
13 X 5.75 - 1025G		3.03	2.90	3.60	6.25	4.10	1.12	1.14	3.19	1.25	4.50	0.750
16 X 6.75 - 1025G		3.03	2.90	3.60	6.38	4.72	0.12	0.14	2.69	1.38	4.54	0.750
19 X 8.75 - 1030G		3.59	3.46	4.20	7.00	5.88	0.25•	0.23	3.31	1.50	5.00	0.750
19 X 8.75 - 1035G		4.19	4.02	5.10	7.12	6.58	0.12	0.12	3.47	1.63	5.00	0.980
23 X 11.25 - 1040G		4.75	4.54	5.70	8.20	7.82	0.00	0.05	4.59	1.75	5.50	1.050
23 X 11.25 - 1040G		4.75	4.54	5.70	8.31	8.26	0.44•	39.00	4.16	1.31	6.00	1.050
30 X 14.25 - 1050G		6.03	5.80	7.20	8.50	10.63	0.44•	37.00•	5.38	1.75	6.75	1.360
30 X 14.25 - 1050G		6.03	5.80	7.20	9.62	9.76	44.00	37.00•	6.00	2.37	7.75	1.360

## Maximum Operating Misalignment

For construction purposes request certified drawing.

SIZE	SINGLE ENGAGEMENT		
	PARALLEL OFFSET INCHES	ANGULAR	
		INCHES	DEGREES
1015G		0.005	1/8
1020G		0.010	1/8
1025G	Do Not Use Single Engagement Couplings To Compensate For Parallel Offset Misalignment	0.010	1/8
1030G		0.015	1/8
1035G		0.015	1/8
1040G		0.020	1/8
1050G		0.020	1/8

## Rating Data and Approximate Weights

BRAKE WHEEL DIA. x FACE AB JB	COUPLING REF.	BRAKE RATING (LB.FT.)	MILL MOTOR SIZE	MAX SPEED RPM	MIN BORE (1)	WEIGHT LBS.		WK <sup>2</sup> (LB.FT. <sup>2</sup> )	
						WHEEL AND COUPLING	LUBE	WHEEL AND COUPLING	COUPLING (NO BORE)
CATALOG #									
8 X 3.25 - 1015G		100	2, 602	2860	0.75	33	0.20	1.4	0.486
10 X 3.75 - 1015G		200	603, 604	2290	0.75	40	0.20	3.5	0.486
13 X 5.75 - 1020G		550	606	1760	1.00	80	0.30	13.1	1.040
13 X 5.75 - 1025G		550	608	1760	1.25	110	0.60	14.7	2.680
16 X 6.75 - 1025G		1000	610	1430	1.25	170	0.60	33.0	2.680
19 X 8.75 - 1030G		2000	612	1200	1.50	170	0.90	81.0	4.900
19 X 8.75 - 1035G		2000	614	1200	2.00	225	1.25	87.0	11.300
23 X 11.25 - 1040G		4000	616	995	2.50	390	2.00	230.0	21.600
23 X 11.25 - 1040G		4000	618	995	2.50	390	2.00	230.0	21.600
30 X 14.25 - 1050G		9000	620	765	3.50	900	4.12	700.0	62.500
30 X 14.25 - 1050G		9000	622	765	3.50	900	4.12	700.0	62.500

(1) For bores less than minimum values shown above consult factory (Flexible and Rigid Hub).



# Hi-Tork™ 300M Series

## DC Magnetic Brake Rectifiers/Controllers

### AC STATIC RECTIFIERS

The AC Static/Rectifier Controller is designed to operate the BE and BEM Type, AISE-NEMA shunt wound 50 volt DC shoe brakes installed on AC powered equipment. The basic unit consists of a multi-tapped power transformer, bridge rectifier, contactor, static control PCB and a protective circuit breaker, all mounted on a steel backing plate for panel mounting on customer's equipment. The unit is designed with a static timing circuit, which eliminates relay contacts. The economizing circuit reduces power consumption and assures fast brake release when power is removed. The forcing circuit assures fast brake release when the power is initially applied to the brake. All models are equipped with a multi-tapped primary transformer for 230V, 460V and 575V single-phase power supplies.

### OPTIONAL FEATURES

- NEMA-Type 3R Enclosures
- NEMA-Type 4 Enclosures
- Anti-condensation heater
- Time delay (Diode—mounted inside enclosure)
- Time delay (Adjustable—customer mounted)

### ORDERING CODE

Brake Controller Designation—ABC  
 Quantity and Size of Brakes  
 Type of Enclosure—(3R or 4)  
 Power Supply 230, 460, 575 VAC/3Ph/60Hz

Example  
 ABC  
 1 x 10"  
 3R  
 460/60

Example:

ABC—1x10"—3R—460/60

Designates an AC Static Rectifier to control a single 10" MBE Brake in a NEMA 3R Enclosure from a 460V/60Hz power supply.

### OPERATION

The static rectifier/controller shown in Fig. 1 is equipped with two electronic circuits one for releasing the brakes quickly (forcing) and the other for maintaining the brakes in the released position. The system utilizes silicon-controlled rectifiers (SCR's) and silicon rectifiers (diodes) to convert AC input to a full wave DC output for energizing the brake coil. When the AC voltage is applied to the control system, the brake relay (BR) is energized and the two SCR's conduct on alternative half cycles. This results in approximately 100 volts being applied to the brake coil. The SCR's are triggered by a free running uni-junction oscillator, which operates for approximately one second. At the end of the period, conduction ceases through the SCR's and the brake holding current is maintained by the 24V AC transformer and rectifier stack circuit.

Notes:

Normally the input to the transformer L1 and L2 would be connected to the terminals of the driving motor and the brake would operate when power is applied to the motor. If desired the transformer may be connected to a fixed AC supply and the brake can be operated by energizing the braking relay (BR) from an external control system. This is achieved by removing links 4 and 5, and links 6 and 7 of the brake control circuit (Ref. Fig 2)

Normal forcing is 100VDC and normal holding is 20VDC. If required, two 50V shunt wound, brake coils can be connected in series and operated from a suitably rated static rectifier controller. In this case the initial forcing voltage of the controller is 200VDC and the holding voltage is 40VDC.

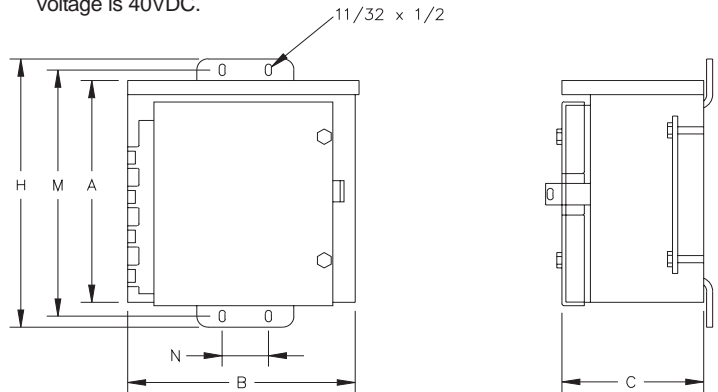

Brake Size	A	B	C	H	M	N
5" - 23" Single, 5" - 13" Dual	24	20	8	26	25	13
16" - 23" Dual, 30" Single	24	24	10	26	25	17



TYPICAL STATIC RECTIFIER IN TYPE 3R ENCLOSURE

# Hi-Tork™ 300M Series Brake Enclosures

The standard 300M Series of AISE-NEMA shoe brakes are suitable for operation indoors, on moist, or dusty applications. When installed outdoors or in extremely wet or abrasive dust environments, some type of brake enclosure is recommended. There are three types of enclosures available to suit a wide variety of installations.

**Drip Proof**—this consists of a simple partial cover, which extends over the top of the brake wheel and shoes

**Type 3R**—This is a lift off enclosure, which covers the entire brake. The enclosure is supplied with a hinged inspection lid and can be provided with one or two shaft slots.

**Type 4**—This enclosure is water-tight and dust-tight and covers the entire brake. The enclosure is designed with a split gasket flanged and fitted with one or two shaft seals to suit the installation.

For low temperature applications the Type 3R and Type 4 enclosures may be fitted with a space heater.



TYPICAL TYPE 3R BRAKE ENCLOSURE

## STANDARD FEATURES

- Stainless steel welded construction
- Primer paint finish
- Available for all 300M Series brakes
- Dimensions available on request

## OPTIONAL FEATURES

- Shaft seals
- Space heaters
- Thermostats
- Conduit box
- Special paint finish
- Aluminum



TYPICAL BRAKE SPARE PARTS

# MAGNETEK



# MATERIAL HANDLING

**Electromotive Systems**

**Telemotive**

**Mondel Engineering**

**YOUR ONE-STOP SOURCE FOR MATERIAL HANDLING CONTROL SOLUTIONS**

## Engineered Systems & Solutions

Project Evaluation  
Application Solutions  
Engineering Design  
PLC/PC Program  
Development  
System Manufacturing  
Project Management  
Installation Assistance  
Field Startup and Test  
Customer Training  
Maintenance Support

## IMPULSE® AC Adjustable Frequency Drives

230, 460, and 575 Volt Power Platforms  
.25– 1,500 Hp  
Exclusive Application Software  
Specific Crane & Hoist Software

## OmniPulse™ Digital Drives

AC in/DC out  
15-800 Hp  
DC in/DC out  
5–500 Hp

## MAC™•2000 Motor Acceleration Control

Single & 2 Speed—up to 15.2 Amps  
Contactor Panels

## Variable Speed Motor Control Panels

Standard Pre-Engineered Systems  
Custom Engineered Systems

## Motors & Accessories

Standard Inverter Duty AC Induction Motors  
Flux Vector Designed Motors

## Power Delivery Systems

ELECTROBAR® — 90, 110, 250, 350 Amps  
ELECTROBAR® FS — 90, 125, 250, 400 Amps  
ELECTROBAR® ELITE — 60, 100, 130, 200 Amps  
ELECTROBAR® HX — 400, 700, 1000, 1500 Amps  
FABA® Conductor Bar Systems — 100 Amps

## ELECTROMOTIVE™ Festooning Systems

Standard Duty  
Heavy Duty  
Mill Duty

## SBP® & SBP2® Pendant Push Button Stations

Standard 2 thru 12 Button Stations  
Custom Configured Stations

## Radio Remote Control Systems

### Pre-Engineered Radio Control Systems

MLTX™  
SLTX™  
JLTX™  
telePilot™  
telePendant™  
Pendant Style

### Engineered Radio Control Systems

MLTX™  
SLTX™  
JLTX™  
Locomotive Control Systems

## Collision Avoidance Systems

Laser Guard®  
Reflex®

## Brakes

### 200S Industrial Shoe Brakes

4"–19" Diameter  
6–2,650 Lb. Ft. Torque  
AC, DC, Hydraulic Actuators  
AC Explosion-proof Actuators

### AISE-NEMA 300M Mill Duty Shoe Brakes

5"–30" Diameter  
10–11,000 Lb. Ft. Torque  
AC, DC, Hydraulic Actuators  
AC Explosion-proof Actuators

### 400D Heavy Duty Disc Brakes

8"–50" Diameter  
50–30,000 Lb. Ft. Torque  
AC, DC, Hydraulic Actuators  
AC Explosion-proof Actuators

### Braketronic™ Control System

Braketronic Controller  
Standard Pre-engineered Panel  
Mill Duty Foot Pedal (optional)

### Brake Kit

Remote Air/Hydraulic Bridge Brake  
Conversion Kit



[www.magnetekmh.com](http://www.magnetekmh.com)

## Magnetek

N49 W13650 Campbell Dr.  
Menomonee Falls, WI 53051  
Toll Free: (800) 288-8178  
Fax: (262) 783-3510

## Magnetek Canada

2610 Dunwin Drive  
Mississauga, Ontario  
Canada L5L 1J5

Toll Free: (800) 792-7253  
Phone: (905) 828-1526  
Fax: (905) 828-5707

Brochure No. 300M-06 Copyright  
© 2006  
Printed in U.S.A.